

NORTEK MANUALS

Operations and Integration

DVL



Table of Contents

Ch. 1	Introduction	7
Ch. 2	System Overview	8
Ch. 3	Getting Started	11
3.1	Checking the Inventory	11
3.2	Connecting the DVL to PC	11
3.3	Finding Instrument on PC	12
Ch. 4	Standard User Interfaces	16
4.1	Web Browser Interface	16
4.2	Viewing DVL Data	17
4.3	Command Line Interface	19
4.4	Data Output	19
Ch. 5	Preparation	20
5.1	Functionality Test	20
5.2	Before Mission	23
Ch. 6	Practical Elements of Operation	24
6.1	Start and Stop	24
6.2	Power Supply	24
6.3	Operation in Air	26
6.4	Coordinate System	27
6.5	Control and Timing	28
6.6	Trigger	29
6.7	DVL Configuration	29
	Bottom Track	32
	Current Profiling	36
	Fast Pressure	37
	Unique ID	37
6.8	Installing DVL on Vehicle	38
Ch. 7	Mechanical Aspects and Maintenance	39
7.1	Instrument Care	39
7.2	Connector Care	40
7.3	Cable Care	42
Ch. 8	Integrators Interfaces	42

8.1	Using the Command Interface	42
8.2	Basic Interface Concept	44
8.3	Command Interface	46
8.4	Ethernet Operation	46
8.5	Telnet Connection	47
8.6	Raw Connections	47
8.7	FTP	48
8.8	HTTP	48
8.9	UDP	48
8.10	Time Synchronization	49
8.11	Triggers	50
8.12	Example of Internal Trigger Command	51
	Example of External Trigger Command	51

Ch. 9 Commands 53

9.1	List of Commands	53
9.2	Wake processor from sleep mode	55
9.3	Instrument main settings	56
9.4	Clock settings	57
9.5	Clock settings as strings	58
9.6	Get clock as string (with ms)	59
9.7	Get clock (with ms)	59
9.8	Bottom track settings	60
9.9	Start measurements	62
9.10	Dvl main settings	63
9.11	Fast pressure settings	64
9.12	Trigger settings	66
9.13	Trigger settings for secondary plan	67
9.14	Read absolute pressure	68
9.15	Current profile settings	68
9.16	Altimeter settings	70
9.17	Instrument user settings	71
9.18	Additional online data formats	72
9.19	Get instrument ID	73
9.20	Reload default settings	73
9.21	Save settings	74
9.22	Enter command mode	74
9.23	Data retrieval mode	75
9.24	Enter measurement mode	75
9.25	Power down	75
9.26	Erase files on recorder	75
9.27	Format recorder	76
9.28	Read configuration	76

9.29	Inquire state	77
9.30	Get error	78
9.31	Get error number	78
9.32	Get error string	78
9.33	Get all	78
9.34	Get recorder state	79
9.35	Write tag output	80
9.36	Precision time protocol	81
9.37	Get hardware specifications	82
9.38	Add license	82
9.39	Delete license	83
9.40	Lists license keys	83
Ch. 10	Output Data Formats	84
10.1	Bottom Track Data Formats	84
10.2	Water Track Data Formats	86
10.3	Current Profile Data Formats	87
10.4	Altimeter Data Formats	88
Ch. 11	Binary data formats	89
11.1	_HeaderData	90
11.2	_CommonData	91
11.3	StringData	95
11.4	_DF3 CurrentProfileData	95
11.5	DF3 VelocityData	99
11.6	DF3 SpectrumData	102
11.7	DF21 BottomTrack / DF22 WaterTrack	103
11.8	DF30 AltimeterData	111
11.9	DF41 FastPressureData	113
Ch. 12	Timing Information	113
Ch. 13	ASCII Data Formats	114
13.1	DVL Bottom Track ASCII formats	114
	DF350/DF351 – NMEA \$PNORBT1/\$PNORBT0	114
	DF354/DF355 – NMEA \$PNORBT3/\$PNORBT4	115
	DF356/DF357 – NMEA \$PNORBT6/\$PNORBT7	117
	DF358/DF359 – NMEA \$PNORBT8/\$PNORBT9	118
13.2	DVL Water Track ASCII formats	120
	DF404/DF405 – NMEA \$PNORWT3/\$PNORWT4	120
	DF406/DF407 – NMEA \$PNORWT6/\$PNORWT7	121
13.3	DVL Current Profile ASCII formats	122
	DF408/DF409 – NMEA \$PNORWT8/\$PNORWT9	122
	DF100 - Prolog NMEA Format	124

	DF101/DF102 - NMEA Format 1 and 2	124
	DF103/DF104	127
13.4	DVL Altimeter ASCII Formats	129
	DF200/DF201 - NMEA Format 200 and 201	129
	DF202 - NMEA Format 202	130
	DF203 - NMEA Format 203	130
Ch. 14	Troubleshooting	131
14.1	Communication	131
14.2	Network	133
14.3	Bottom Track	133
14.4	Software	135
Ch. 15	Appendices	136
15.1	Glossary	136
15.2	Communication and Ethernet	139
15.3	BIT Test	140
15.4	Noise Troubleshooting	149
15.5	Cable Connector Pin Configurations	171
15.6	Mechanical Drawings	175
15.7	Proforma Invoice	187
15.8	Sound Pressure Levels	188
15.9	Coordinate System Conversion	189
15.10	Checksum Definitions	190

1 Introduction

This manual is designed to familiarize users of the Doppler Velocity Log (DVL) with the system. The manual includes chapters covering how to get the instrument up and running as quickly as possible, functional testing, basic software and web interface information, and tips for maintenance and troubleshooting. This manual also includes information needed to control and integrate the DVL with other vehicle systems. This section is aimed at system integrators and engineers with interfacing experience, but it also includes examples on how to configure and start the instrument for more inexperienced integrators.

Nortek online

At our website, www.nortekgroup.com, you will find technical support, user manuals, FAQs and the latest software and firmware. General information, technical notes, and user experience can also be found here.

Your feedback is appreciated

If you find errors, omissions or sections poorly explained, please do not hesitate to contact us. We appreciate your comments and your fellow users will as well.

Contact Information

We recommend first contacting your local sales representative before the Nortek main office. If you need more information, support or other assistance, you are always welcome to contact us or any of our subsidiaries by email or phone

Email: inquiry@nortekgroup.com (general inquiries), support@nortekgroup.com (technical support)

Phone: +47 67 17 45 00

You can also write us at:

Nortek AS
Vangkroken 2
1351 RUD
Norway

Version/revision	Date	Comments
Version 2016.1	03.2016	Initial version
Version 2016.2	05.2016	
Version 2016.3	22.11.2016	
Version 2017.1	30.05.2017	
Version 2017.2	05.07.2017	
Version 2017.3	20.10.2017	
Version 2018.1	05.10.2018	
Version 2020.1	09.10.2020	Major updates
Version 2021.1	08.03.2021	Minor updates

Version 2021.2	24.11.2021	Minor updates to commands/data formats
Version 2022.1	20.05.2022	Additional commands/data formats
Version 2022.2	05.10.2022	Updated contact information and new data format overview
Version 2023.1	22.03.2023	Created Operation Principles chapter, and added DVL333. Updated Data Formats.
Version 2025.1	08.04.2025	Combined DVL Operations and Integrators manuals into single document. Added noise appendix.
Version 2026.1	02.03.2026	Added: New license information, pinout diagrams, sound pressure levels. Edited/Corrected: Data format information, water track cell size and bit test information.

2 System Overview

A DVL (Doppler Velocity Log) is an acoustic Doppler instrument which has the ability to estimate the velocity relative to the sea floor (Earth being the frame of reference) or relative to the water. Nortek DVLs are part of the AD2CP hardware family which will be referenced throughout this document.

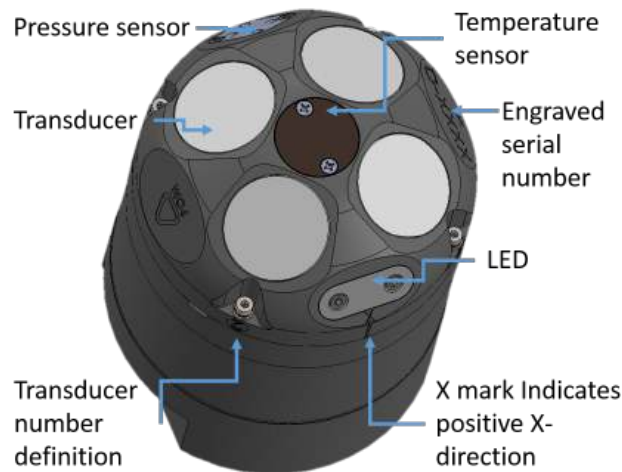
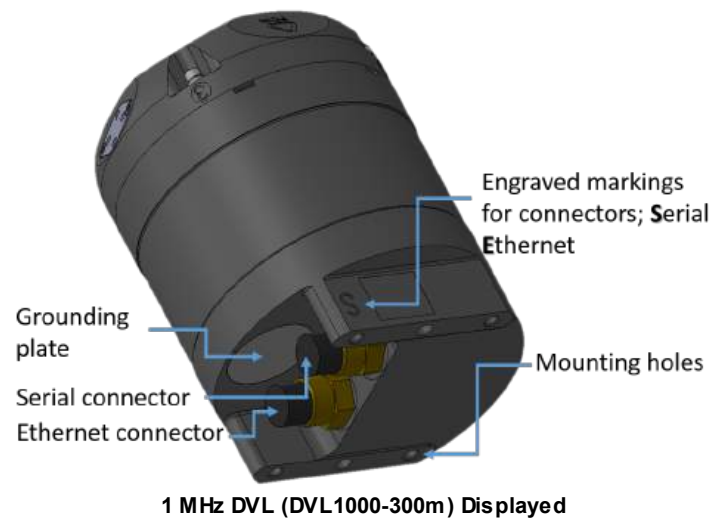

The DVL comes with a high precision pressure sensor, which provides a means to estimate depth and a temperature sensor that provides data used for calculating speed of sound. Nortek DVLs utilize acoustic beams oriented in a diverging, convex configuration. Each beam provides an estimate of range so that the altitude over the bottom may be estimated. The system comes with two 8-pins connectors to enable Serial and Ethernet communication. Refer to the [Connector Pin Configuration](#) section for pin outs.

When power is applied the blue LED on the DVL will start flashing (unless LED has been disabled in the most recent configuration). The flashing signifies that the DVL is in measurement mode. There are three settings for the LED: ON allows the LED to indicate operation and modes; OFF disables the LED completely. ON24H enables the LED for 24 hours after the instrument starts pinging.

The current Nortek DVL family has four main variants specified below, each of which have a shallow and a deep water version. Full technical specifications and specialized models are available on [our website](#).

Specification	DVL1000	DVL500 Compact	DVL500	DVL333
Frequency	1 MHz	500 kHz	500 kHz	333 kHz
Minimum altitude	0.1 m	0.1 m	0.1 m	0.1 m
Maximum altitude	75 m*	175 m*	200 m*	375 m*
Long-term accuracy	±0.1% / ±0.1cm/s**, >1%***	±0.1% / ±0.1cm/s**, >1%***	±0.1% / ±0.1cm/s**, >1%***	±0.1% / ±0.1cm/s**, >1%***
Maximum ping rate	8 Hz	8 Hz	8 Hz	8 Hz
Velocity resolution (Bottom Track)	0.01 mm/s	0.01 mm/s	0.01 mm/s	< 0.01 mm/s
Depth rating shallow (deep)	300 m (6000 m****)	300 m (6000 m****)	300 m (6000 m)	300 m (6000 m)
Weight in air/water shallow (deep)	1.7 kg / 0.3 kg (4.15 kg / 1.7 kg)	1.7 kg / 0.3 kg (4.15 kg / 2.5 kg)	3.5 kg / 0.5 kg (7.0 kg / 4.1 kg)	3.5 kg / 0.5 kg (7.0 kg / 4.1 kg)

*Maximum altitude is dependent on external noise conditions of vehicle/environment and bottom conditions.

**Export controlled license

***License free (NLR)

****DVL 500c/1000 products delivered before March 2024 are depth rated to 4000m, not 6000m.

Please contact Nortek if you are unsure about the depth-rating of your instrument.

3 Getting Started

This chapter is useful when connecting to the DVL for the first time, connecting the instrument to a PC and other information that is important for first time use.

3.1 Checking the Inventory

Check the content of the received package against the packing list included in the shipment. Do not hesitate to contact us if you find any part of the delivery missing.

3.2 Connecting the DVL to PC

Communication Harness

Nortek DVLs feature serial and Ethernet communication ports. The communication harness is the hardware that connects the serial and Ethernet ports to the electronics inside the pressure housing. There are two harness options available from Nortek.

The standard harness is always fitted unless specifically requested by the customer. Key features to note:

- Only one port can be used at a time. If both ports are connected to power, the port that receives the higher voltage will be enabled. If there is an equal voltage sent to both ports, Ethernet will be enabled. It is recommended to send power to one port at a time, but it will not damage the DVL if power is applied to both ports at once.
- Both ports are capable of Tx and Rx communication when the port is enabled.
- The port that is disabled cannot send information or receive commands.

The auxiliary serial harness is a specialty harness useful for certain vehicles. Key features to note:

- This harness features a common power line, which means both ports will be active whenever power is applied to the DVL. Power can be applied to either port, there is no change to DVL operation based on port selection. It will not damage the DVL if both ports are connected to power.
- The auxiliary serial port is limited to Tx communication only.
- The serial port will output data whenever the DVL is connected to power and in measurement mode.
- All Rx communication must be done through Ethernet.
- It's possible to view data from Ethernet and serial simultaneously using this harness.
- Different data format types can be sent simultaneously to serial and Ethernet.

Connector Care

Please reference the [Connector Care](#) section before mating the cable in order to avoid damage.

Ethernet communications (recommended for initial setup)

Ethernet communication has been implemented using a dedicated network processor and requires power from a power supply to the external power breakout on the cable. Providing power through the Ethernet connector will also provide power to the rest of the electronics. **Note: DVL instruments cannot use Power over Ethernet (PoE) technology. Using PoE with your DVL will damage the electronics board and require repair.**

- Connect the Ethernet cable to the 8 pin connector on the DVL marked 'E' for Ethernet and apply power to the breakout cable. The blue LED should start flashing after a short period of time (unless LED has been disabled in the most recent configuration). For more details regarding the power supply for the instrument, consult the [Power Supply](#) section.
- The first time using the instrument will require the network address to be properly configured for the network. For new users who are unaware of how the network is set up, the instrument should be plugged either directly into the computer's Ethernet port or via an Ethernet switch connected to the computer. For more information consult the [Communication and Ethernet](#) section.
- If the computer's Ethernet port has status lights, verify that the link is active by looking for a stable green light on the port. If an Ethernet switch is used, the Ethernet port should also show an active Ethernet link. If the status light is not lit please refer to the [Troubleshooting](#) chapter.
- Check the internet access status in the notification area on the task bar of your PC (see image below)
- Continue reading the next section on how to [find the instrument on the PC](#)

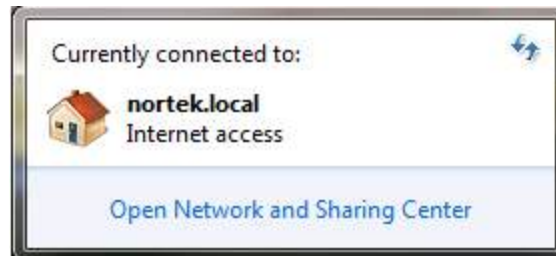

Serial communications

- Connect the Serial communication cable to the 8 pin connector on the DVL marked 'S' for serial.
- Use a Serial-to-USB converter to connect the cable to the PC. If the converter has light indicators, confirm that they are lit. It is recommended to connect the cable and instrument to the converter before plugging the converter into the PC. This is done to avoid a problem related to automatic detection of a driver. If necessary, check that the correct software driver is installed.
- Apply power to the breakout cable. The blue LED should turn on when power is applied (unless LED has been disabled in the most recent configuration). Note: When powering over serial, the DVL will resume in whatever mode (command or measurement) it was in before power was removed.
- Use the command line interface to switch operation mode or change baud rate and serial protocol. Refer to the [Commands](#) section for the specific commands. The correct serial port and baud rate can also be specified through the web browser interface or in the MIDAS software (see [Standard User Interfaces](#)).

3.3 Finding Instrument on PC

Nortek Discover

The Nortek Discover application is a small Windows program that provides a means to locate and configure network information for instruments (NortekDiscover.exe can be downloaded on the Nortek Website via the software page). Note that it may take a few minutes to locate the device when connecting for the first time. The search application requires an up-to-date version of Java installed on the computer. All instruments discovered on the network will be displayed:

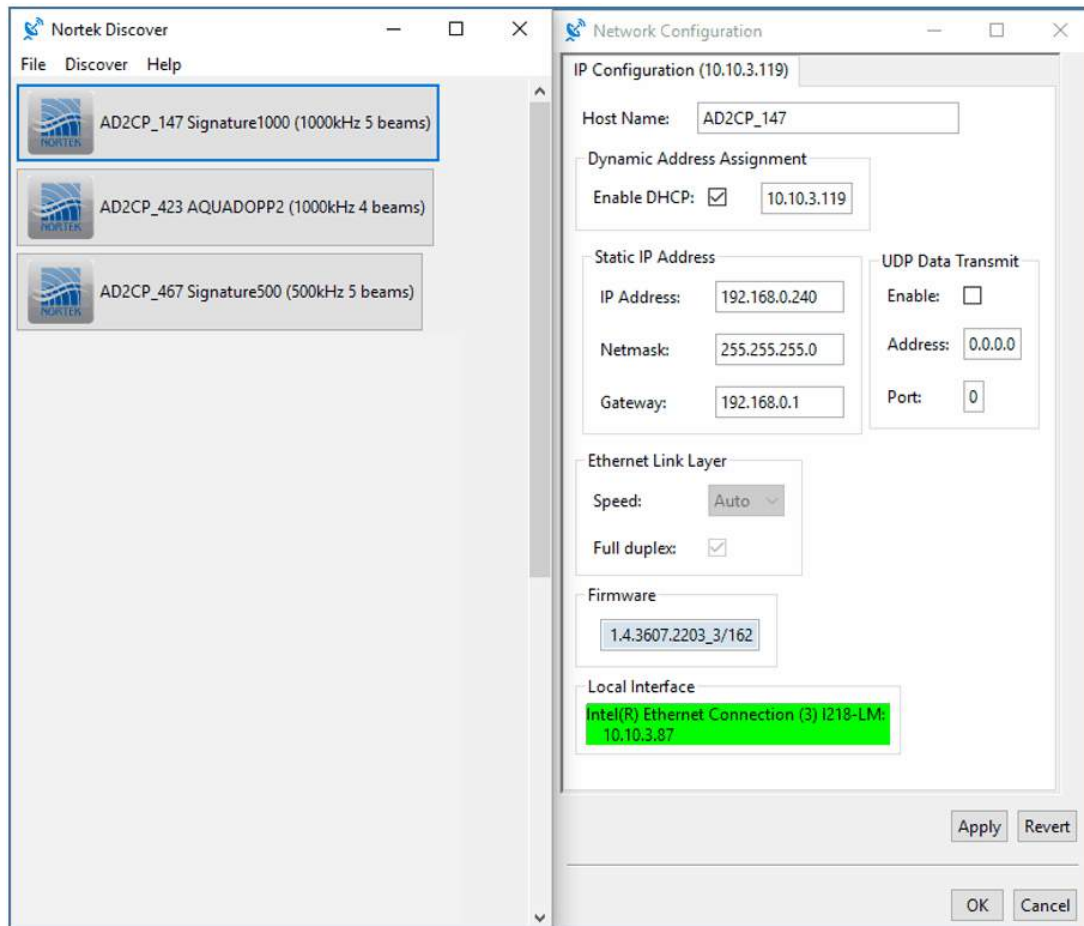

Once found, IP address information is displayed to facilitate a connection. Note: If the Local Interface is highlighted in red, it will not be possible to connect to the instrument because the IP configuration does not match that of the computer running the Discover protocol. The IP settings must be changed in the computer or the instrument to allow IP connectivity.

Host name: A user defined name assigned to the host. Unless your network or host machine is configured to specifically associate an IP address with this name, this name cannot be used for standard network operations (e.g. ping).

Dynamic Address Assignment: Use a dynamically assigned IP address from a DHCP server or from AutoIP instead of a user supplied IP address. The IP address that gets assigned is also shown in this panel. AutoIP allows a local domain dynamic IP address to be assigned without the presence of a DHCP server. An instrument connected directly to the host will be assigned a special address in the 169.254.xxx.xxx address range. In order for the Windows host to select an appropriate address, the Automatic private IP address option in the Internet Protocol Version 4: Alternate Configuration menu must be enabled.

Static IP address:

IP address: The IPv4 address to manually assign to the network interface.

Netmask: The network mask used to identify the local subnet for the network.

Gateway: The router address used to connect to machines that are on a different subnet from the instrument. The gateway must be on the same subnet as the IP address selected.

UDP Data Transmit:

Enable: This toggles UDP data transport on and off. UDP transport may be required if the client receiving the data does not want to re-connect to the instrument after the instrument has been power cycled.

Address: This is the address of the receiving client.

Port: This is the port of the receiving client.

Ethernet Link Layer:

Speed: The desired speed of the Ethernet interface (not changeable).

Full Duplex: Whether or not full duplex mode for the Ethernet interface is enabled (not changeable).

Firmware: The version of firmware currently running in the instrument.

Local Interface: Shows which network interface on the computer is being used to communicate with the instrument and whether or not full IP communications can be established. If the interface is highlighted in red then it is not possible to connect to the instrument because the IP configuration does not match that of the computer running the Discover protocol.

Note: You can right click in the configuration window to get access to the support file, open the web browser, browse data disk, change instrument picture, settings for blink location LED or reboot the network processor.

If you have a specific IP address for the instrument, you can search for it directly under Discover > Search for Address. Simply type the IP address or domain name. This will open the IP configuration pane (to the right in the figure above).

Universal Plug and Play

In addition to the proprietary discovery protocol, the UPnP (universal plug and play) protocol is also supported by the DVL's platform. This allows operating systems which are UPnP capable to discover the instrument with no need for proprietary software. UPnP will only operate correctly if the IP address of the instrument is correctly configured for the network. For more information consult the [Appendix](#). To find the instrument icon in Microsoft Windows, open Network view on the computer.

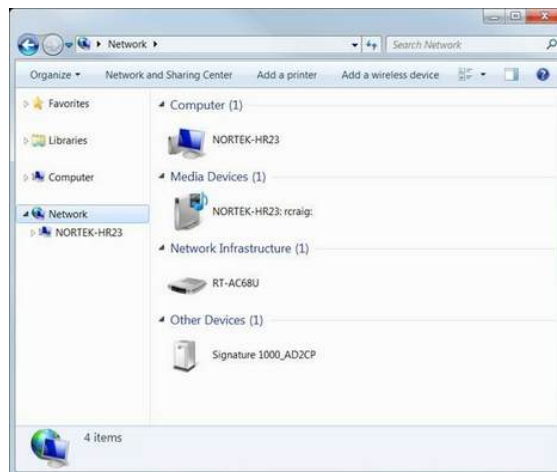

Double clicking on the instrument icon brings up the web page interface. Right clicking and selecting Properties gives the IP address and other instrument configuration information.



In order for UPnP to operate on Microsoft Windows platform, Network Discovery needs to be enabled. This is normally enabled by default on "Home" and "Work" networks but disabled on "Public" networks. To see if Network Discovery is enabled, open the Network and Sharing Center (Control Panel: Network and Internet: Network and Sharing center) and click on the *Change advanced sharing settings* selection. This will bring up the various network types (Home/Work/Public). Select the network type that the instrument is connected to and ensure that *Turn on network discovery* is selected for that network.

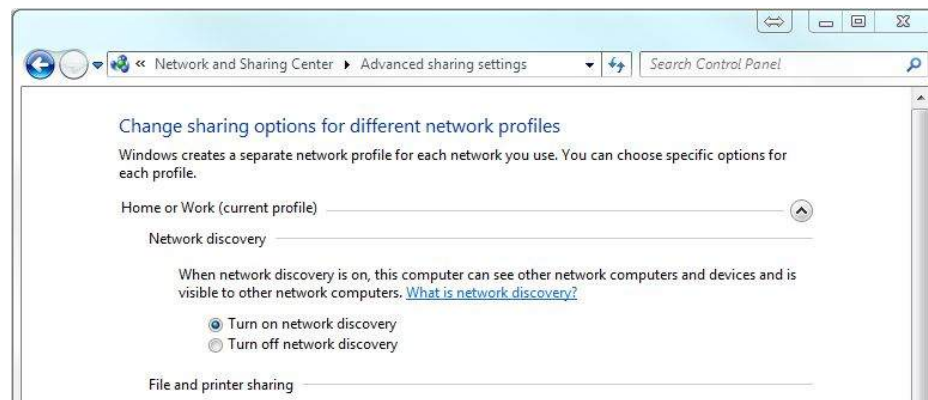

If the network is a public network, it is recommended that network discovery be turned off after interaction with the instrument has been completed.

4 Standard User Interfaces

You have the option of communicating with the DVL through a web browser interface, MIDAS software or a command line interface. If you want to use the command line interface, please refer to the [Command Line Interface](#) and [Integrators Interfaces](#) sections for more information. The web browser interface offers a much more intuitive experience when configuring the DVL for operation. Note, it is not possible to communicate with the instrument from two different interfaces at the same time.

4.1 Web Browser Interface

The instrument's IP address is used to access the web browser interface. The first step is to find the assigned IP address for your system which implies that you are properly connected to the instrument. A detailed explanation of this can be found in [Connecting the DVL to PC](#) and [Finding Instrument on PC](#) sections above.

Once you have discovered the instrument and found the IP address, type it into the address bar of your web browser. The instrument specific web site is divided into the following menu options:

- Measurement Configuration
- Instrument Settings
- Additional Online Data Formats
- Display Data
- Network Configuration
- Maintenance
- Logs
- Security
- Data Download (HTTP)
- Data Download (FTP)
- Applications
- Documentation
- Log out

Each parameter within a menu is described in detail in the overview to the right-hand side of the browser page:

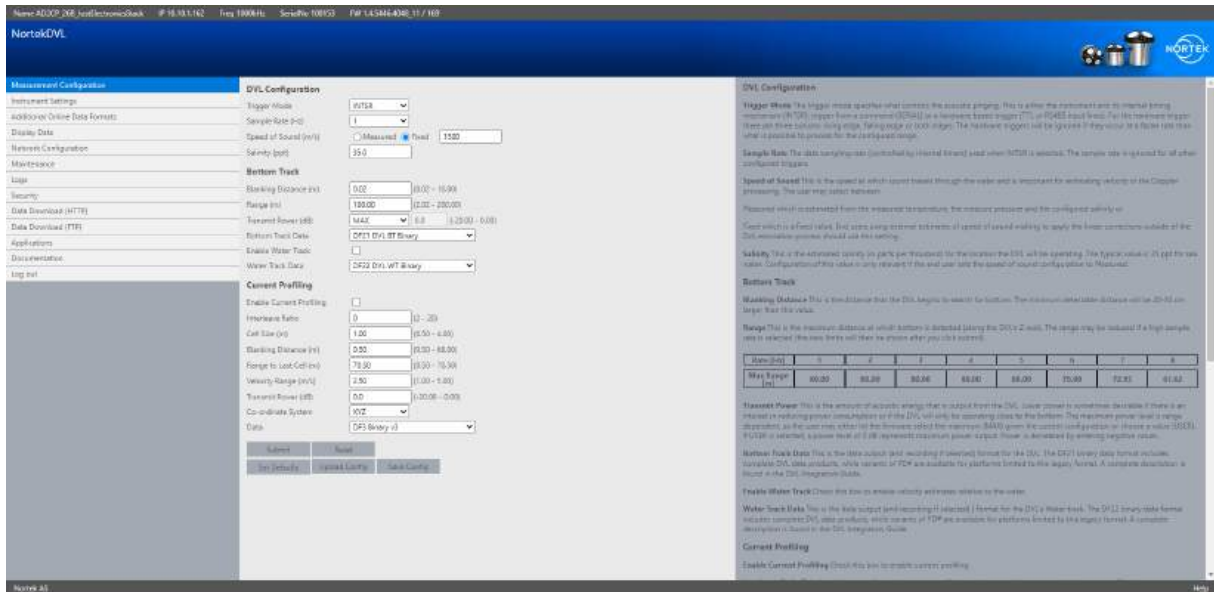

4.2 Viewing DVL Data

The most user friendly way of visualizing a DVL data stream is to open the Data Display tab within the DVL's web browser interface. This displays a simplified view of live data output from the DVL. It includes Pressure, Velocity (beam), Figure Of Merit (beam), Distance, Velocity (XYZ), and Figure Of Merit (XYZ). Note that invalid data is not displayed and such data is very common when attempting to operate in a bucket or tank with poor acoustic conditions. Refer to the section on [Functionality tests](#) for general DVL checks.

Using MIDAS Software

For a more complete data visualization, the MIDAS software (Multi-Instrument Data Acquisition System) is useful if you are interested in looking at data online for short periods of time. The file can be downloaded directly from the Applications tab when connected to the DVL via the web page interface (see [Web Browser Interface](#)). The software requires a Java Virtual Machine (JVM) to be installed. MIDAS software has been tested with Sun JVM available from <http://www.java.com> but it is also known to be fully functional with other JVMs. Please note that MIDAS has a software manual available for download (Click **Help** > **SW Manual**).

The Nortek DVL, together with the MIDAS software, offers a Spectrum Analyzer function. This is particularly useful when trying to identify sources of acoustic or electrical noise on board a vehicle. Consult the MIDAS help files and the [Noise Troubleshooting](#) appendix to learn more about this feature.

System requirements:

1 GHz x86 based host machine (dual-core recommended for imaging)
Windows NT, Vista or Windows 7 (32- or 64-bit) with Java Virtual Machine installed (the software will operate with both 32- and 64-bit JVMs. Using a 64-bit JVM greatly increases the size of the MATLAB data files that can be exported by the software.
1 GB of RAM (2 GB or higher is recommended)
USB port
Minimum display resolution of 1024x768, 256 color

After successful installation, continue with the following steps if connecting via Ethernet. If using Serial port communication, skip to the next paragraph 'Connecting via Serial'.

Connecting via Ethernet:

- Open MIDAS software and click **Connect > Network Discover**. This Discovery tool lists all instrument available on the network. The following options will be presented:
 - IP address: A green background indicates that the IP address is properly configured for the network it is connected to. If the background is red, the IP address must be reconfigured using the **Discover** option from the menu bar. Refer to the MIDAS manual for more details (Click **Help > SW Manual**).
 - Port timeout is the length of time the software will wait for a response from the instrument before timing out and issue an error message. Default: 2000 ms.
 - Username/password fields. Username is the command interface user name used for connection. Default username/password: "nortek"/" " (blank).
 - Note that it may not be possible to "discover" instruments that are connected to the local network through a router.
 - You can also select **Connect>Network parameters** if you need to set the IP address and name explicitly. This mode of operation is useful for networks in which the discovery protocol might not work (e.g. through multiple routers, firewalls or through VPN connections).
- Click Apply. You will typically be prompted to switch the instrument into command mode. An instrument display panel will appear, where you can view the associated data for the current configuration as well as the action buttons for the instrument. Pressing the play button will start a measurement with the current configuration. Review the MIDAS software manual (Click **Help > SW Manual**) for more detailed information about the general operation and functionality of the software.

Connecting via Serial:

- Open the software and click **Communication > Serial AD2CP**. The dialog lists the following:
 - Instrument name (can be specified if desired).
 - Serial Port, which displays the available serial ports detected in the system.
 - Port speed displays the requested baud rate for connection to the instrument. A baud rate of 115200 is recommended. Note that not all RS232 USB serial converters support data rate above 115200.
 - Port timeout is the length of time the software will wait for a response from the instrument before timing out and issuing an error message. Default: 2000 ms. If you experience connection problems you can try to increase the timeout value, e.g. 10000 ms.
- Click Apply. The software will start searching for the instrument by issuing commands on the selected serial port at various port speeds (starting with the chosen speed). The baud rate will be changed to the elected baud rate during this process.

- After the instrument has been connected, an instrument display panel is created showing the associated data displays for the current configuration as well as the action buttons for the instrument. Pressing the play button will directly start a measurement with the current configuration. Check out the MIDAS software manual (Click **Help > SW Manual**) for more detailed information about the general operation and functionality of the software.

4.3 Command Line Interface

The command interface makes it possible to communicate with the instrument using a terminal emulator and a set of commands. A short introduction is described below. For more details see [Integrators Interfaces](#):

- The interface is ASCII based and line oriented. Commands are terminated with CR/LF.
- Optional encapsulation of commands using NMEA style prefix and checksum ensure data integrity.
- NMEA style commands will return argument names in their response.
- Argument limits can be retrieved through commands.
- Comprehensive validation and error handling is implemented.
- Invalid configurations return the erroneous argument with limits directly so that each subsequent error can be handled until a valid configuration is achieved.
- A single command can be used to retrieve the complete configuration of the instrument with optional output to file.
- Commands to set default parameters.
- External controllers can use commands to store external data in raw data file (e.g. GPS position).
- Note that Telnet is disabled on the newer Windows systems (>Win 7). Consult Microsoft support for simple steps on how to enable it.

4.4 Data Output

The DVL can be configured to include both water track and current profile in addition to the standard bottom track. These three modes have different output data formats and can be output in either binary or ASCII format. The [Integrators Interfaces](#) section contains a detailed format description for all types data outputs. The Nortek DVL supports older protocols which have been available (PDxx variants). Otherwise, system integrators may choose to use native Nortek data formats which offer expanded information (independent beam information and quality parameters) and are delivered in efficient data packets.

Stream data serially

The easiest way to stream data from the DVL is to:

- Use the Ethernet cable to connect the instrument to the PC and open the web interface.
- After you have configured the DVL, go to the instrument settings option. Select the correct serial port type (RS232) and serial port baud rate.
- Click Submit. The DVL should enter measurement mode as indicated by the blue LED flashing (unless LED is disabled in current configuration) at the sampling rate.
- Disconnect the Ethernet cable and power.
- Connect the serial cable and power. Data will stream out over the serial port immediately.

5 Preparation

From this point on it is assumed that a stable, reliable connection with the instrument has been established. This is necessary to continue onwards for the next few sections of the manual. If the instrument is unable to connect with your PC please revisit the [Getting Started](#) chapter or consult the [Troubleshooting](#) chapter.

5.1 Functionality Test

Before every mission, it is strongly recommended that a functionality test is performed to ensure that the various components work as intended. Before continuing, make sure your instrument is connected as described in [Connecting the DVL to PC](#). Functionality testing for the pressure and temperature sensors may be performed by observing the data output (as plots or text) in the Display Data page of the web browser interface.

Temperature

To test the temperature sensor simply check to see that the displayed value correlates with the current air or room temperature. Then place a finger on the sensor and observe to see that the temperature starts to rise.

Pressure

The pressure sensor outputs the absolute pressure value in units of dBar. During production, the sensor is adjusted to 9.5 dBar to output the gauge pressure (pressure relative to the atmospheric pressure). The pressure sensor cannot output negative values. In air, the pressure sensor will output a value of 0.2-0.7 dBar, depending on atmospheric conditions. Test the pressure sensor by submerging the instrument in approximately 0.5 m of water. The value should read 0.5dBar + the ambient pressure of 0.2-0.7dBar. An alternative way to test whether the sensor is functioning is by forming a seal around the sensor with your mouth and blowing to observe an increase in pressure.

Recorder

Note: We recommend starting new missions with an empty recorder if you plan on storing data internally. Before you erase the recorder, make sure that you have transferred all data you wish to retain.

- Go to the Web interface > Maintenance > Erase SD card.
- Or use the ERASE,9999 command (ref. [Commands](#) section)

Firmware

The firmware should be the latest version for your instrument. You can check to see if there is an update on the Maintenance tab of the web browser interface. Release notes can be found on the [Nortek website](#). The firmware is upgraded on both the DSPs used within the instrument; the SEC (Serial Ethernet Converter) and the BBP (Broadband Processor). A progress page on the web interface showing the status of the firmware upgrade is automatically updated until the process is complete. Note that after upgrading the SEC, the SEC must be re-booted to use the new firmware. The BBP automatically re-sets itself when the new firmware has completed loading.

Transducers

A functionality test of the bottom track is often difficult in a laboratory setting. This is because the acoustic conditions of buckets or tanks are not representative of in-field conditions. The most important point to evaluate is the response of the transducers, not the bottom track capabilities when testing in a bucket or tank. The following outlines how one can confidently evaluate each of the four transducers

In order to confirm that the transducers are functional, one will need to evaluate the change in response as the DVL pings in the air verses how it pings in the water. This may be done by enabling the current profile mode in the measurement configuration, only including a single cell (no current profiling license required). The configuration is illustrated in the image below. Once the configuration is complete and the DVL is pinging, you may submerge the DVL in water (a bucket will do). You will see that the amplitude in this first cell will increase from its noise floor (approximately 27 dB) to a large amplitude (approximately 85 dB). Examples for measurements in-air and in-water are shown below.

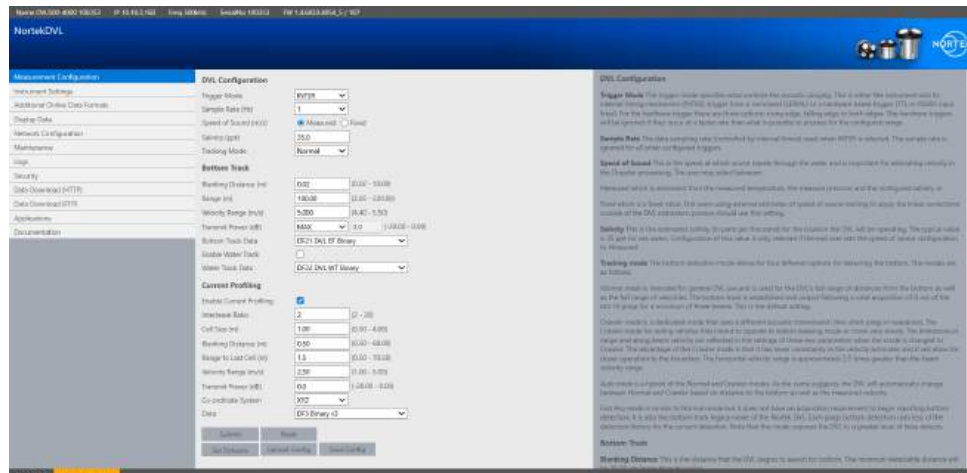

Enable the current profile mode in the measurement configuration and include only a single cell.

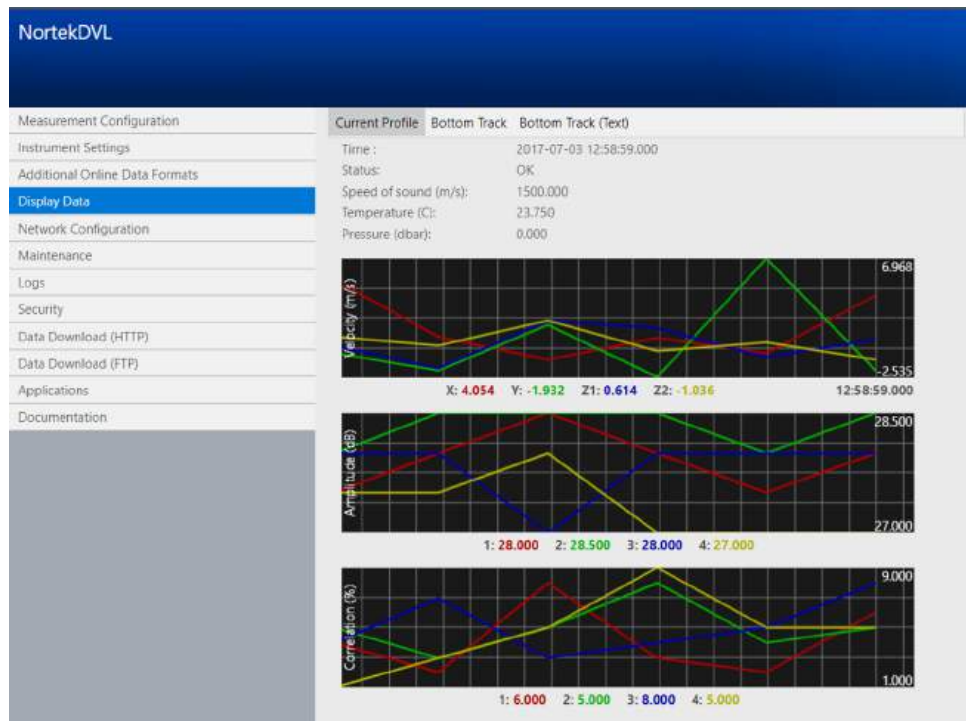

In air, the amplitude in the first cell will be at the instrument's noise floor, approximately 27 dB.

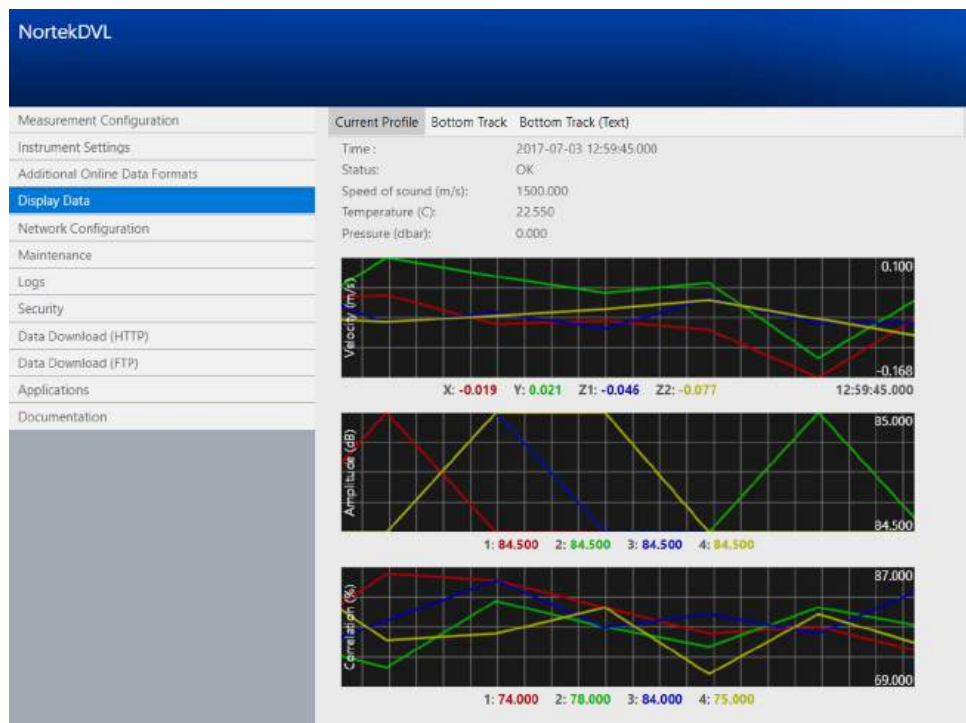

In water the amplitude in the first cell will increase to a large amplitude, approximately 85 dB.

5.2 Before Mission

With the previous sections of this chapter successfully completed you are now ready for your final preparations before deployment.

- It is vital to remember to connect the dummy plug to any connectors that are not in use. See [Connector Care](#) section for more details on mating connectors.
- Connectors should be greased before mated (see [Connector Care](#) section for more details).
- When properly mated, the engaging nut on the cable plug will thread smoothly into the receptacle shell until it abruptly reaches a point where it cannot be hand-tightened any further. At this point the mating surfaces of the plug and receptacle are in contact, and have formed a good seal. The amount of force required to tighten the engaging nut should stay consistent while tightening. If resistance builds throughout the tightening process, the connectors are not mated properly and will not form a good seal.
- We recommend starting new missions with an empty recorder if you plan to store data internally. Before you erase the files, make sure that you have transferred all data you would like to retain.
- The DVL measures absolute pressure. The pressure offset selected is the pressure reading for offsetting absolute to relative pressure. Atmospheric pressure is typically 10.0 dBar, while factory setting is 9.5 dBar to get non-zero readings when out of water. This offset can be set through the web browser interface under Instrument settings (see image below).
- The Mounting Angle may be set to the non-zero value if the DVL's X direction is different from the vehicle's or INS's forward direction. See the section on [Coordinate System](#) for further clarification.

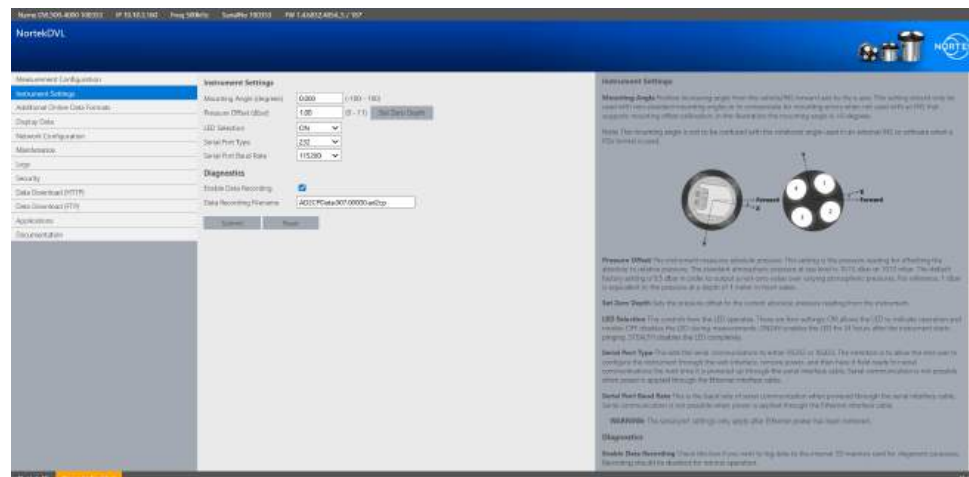

6 Practical Elements of Operation

6.1 Start and Stop

The DVL retains its current configuration when power is removed.

If the DVL is connected via serial and the power is removed, it will always return to the same mode (command or measurement) when power is reapplied.

If the DVL is connected via Ethernet it will always revert to measurement mode whenever power is applied. Note that there will be a short (1-2 second) period where the DVL stops pinging to evaluate its network state. More details around the various modes of operation are described in the [Integrators Interfaces](#) section.

When the DVL is configured using the web browser interface it will generally be measuring and outputting data continuously except for the short period when a new configuration is applied. When configured using command line, the measurement must be started manually after the reconfiguration. Once started, the DVL will stay in measurement mode until it is explicitly stopped. This is also true when the DVL is power cycled as explained above.

6.2 Power Supply

Selecting power supply to a Nortek DVL

The DVL input voltage range is 12-48VDC; we recommend 24VDC. The power supply must be able to deliver an absolute minimum of 15W continuously. 15W is the peak (one-second average) power consumption of the DVL. We recommend using a power supply rated to a minimum of 20W.

The power supply should have a minimum continuous current limit of 1.5A. The DVL will not draw any currents above 1.5A during normal operation. Power supplies with a hiccup-mode current limit should be avoided.

Note: DVL instruments cannot use Power over Ethernet (PoE) technology. Using PoE with your DVL will damage the electronics board and require repair.

The switching frequency and harmonics of the power supply must be outside the DVL's acoustic bandwidth. Stay away from the following bands:

- DVL333: 290 kHz – 380 kHz
- DVL500: 430 kHz – 570 kHz
- DVL1000: 870 kHz – 1130 MHz

Inrush current

The DVL will experience an inrush current when power is applied and every time the systems wakes-up from sleep mode. See the figures below for amplitude and duration.

Power On Current Draw		
Power Supply (v)	Peak Current (amps)	Duration (Milliseconds)
15	2.8	10
24	3.6	10

Current draw at power on

Power supply turned on at approximately 1sec.

The first high spikes is low energy system inrush current. The peak value is dependent on external impedance.

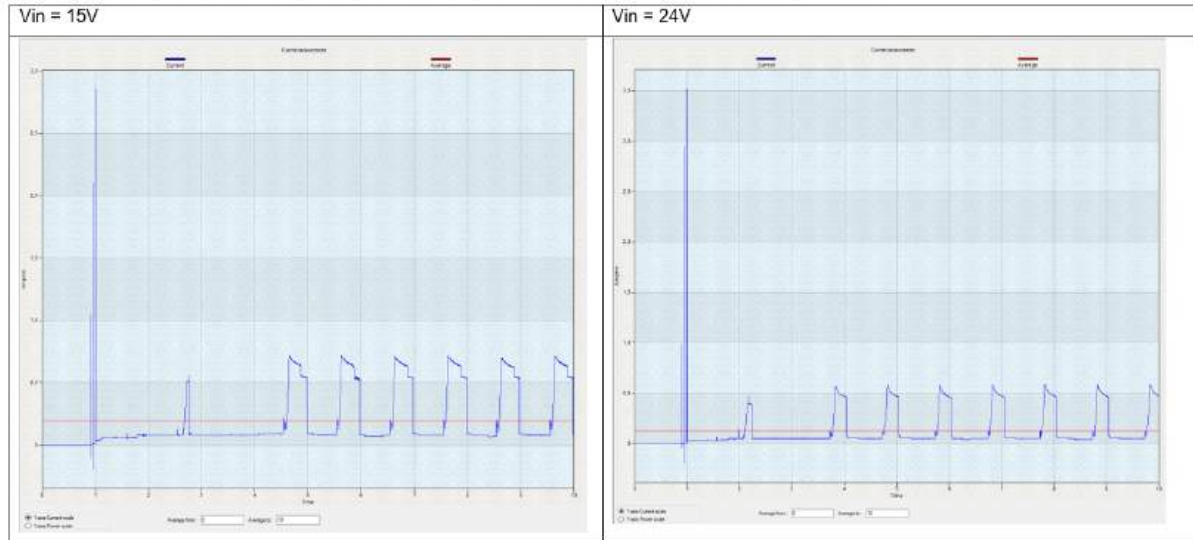

Current draw during sampling

During sampling, there will be a rise in current to the DVL. This will change depending on the configuration of the DVL and the power supply utilized. See the figures below for some samples of expected amplitude and duration.

Sampling Current Draw						
Power Supply (Volts)	Sampling Frequency (Hz)	Blanking Distance (M)	Range (M)	Transmit Power (dB)	Peak Current (Amps)	Duration (Milliseconds)
15	1	0.02	200	0	0.65	250
15	3	0.02	150	-1	0.65	250
24	1	0.02	200	0	0.5	250
24	3	0.02	150	-1	0.5	250

Power draw from Ethernet

When connected to the DVL via Ethernet, there will be an average baseline power usage of 0.7 watts. This baseline power usage from Ethernet will remain constant regardless of operation mode.

Grounding DVL

A common problem for DVLs is electrical noise caused by common mode noise on the power lines. This often is generated in a galvanic isolated power system, which will create an electrical field between the

DVL and seawater. The best way to mitigate this is to have a good electrical connection between the negative power input to the DVL and seawater. This can be done in several ways.

- On standard production units the DVL will be grounded through the housing when exposed to seawater. Deep water variants achieve this through contact with seawater at any point on the titanium housing.
- On the shallow water OEM versions, it's achieved through the grounding plate, typically located near the 8 pin connectors on the DVL.
- For OEM versions this must be done via the grounding cable on the wiring harness. The cable should be connected to a part of the vehicle's frame that has a good electrical connection to seawater. Because of corrosion issues, this connection is normally made through a capacitor (see Figure 1). Note: In production units the capacitor is built into the housing's grounding system.

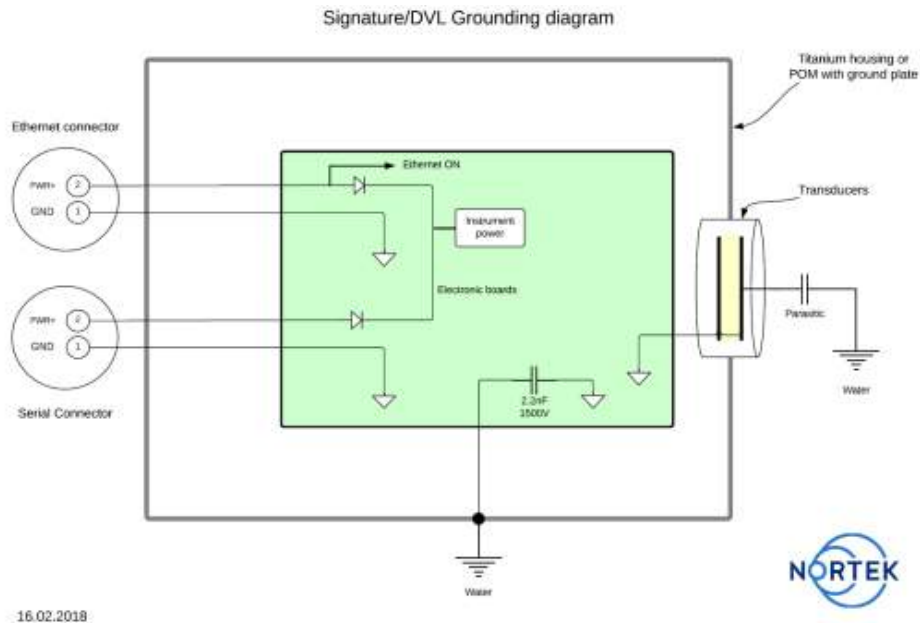

6.3 Operation in Air

Nortek DVLs of frequencies 333, 500, and 1000 kHz are safe to operate in air without harming the transducers or electronics. There is no limit to the duration, however one will note that the electronics will warm the enclosure of the DVL. For this reason it may be sensible to limit operation during normal working hours and not have the unit actively transmitting for multiple days. The frequency of the transmission is not in the audible band but harmonics may lead to mild discomfort with continual use. In such case, the power level for the ping may be turned down as much as 20 dB (PL = -20) or it may be entirely turn off (PL = -100). Consult the [Bottom Track](#) section for instructions on how to change power level. Note that it is important to set the power level back to desired level (typically maximum) prior to deployment.

6.4 Coordinate System

BEAM

For bottom track, the reported velocities are positive when the motion is towards the transducer. For current profile, the reported velocities are positive when the motion is away from the transducer.

XYZ (Cartesian coordinate system)

Use the right-hand-rule to remember the notation conventions for vectors. Use the first (index) finger to point in the direction of positive X-axis and the second (middle) finger to point in the direction of positive Y. The positive Z-axis will then be in the direction that the thumb points.

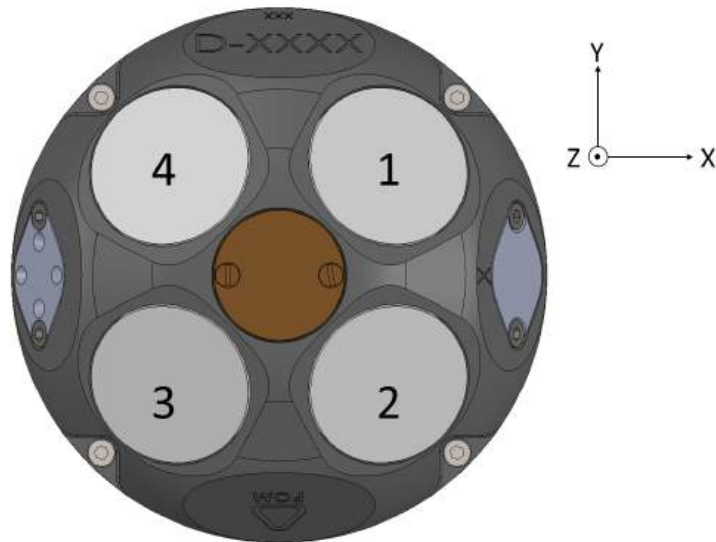

DVL beam numbering and axes convention. Note that positive Z is pointing out of the page.

The coordinate system definitions differ between DVL manufacturers. The end user does not need to take any special consideration of the coordinate system. The correct coordinate system is dictated by the selection of which data format is used. This means the selection of the correct coordinate system and all necessary conversions are handled by the Nortek DVL.

Note: The positive X-direction for the DVL needs to be oriented on the vehicles forward axis. Rotational offsets can be adjusted via the Web Browser Interface or with command line. Looking from above towards a DVL mounted in a downward-looking position, the mounting offset is positive *clockwise* from the X-axis.

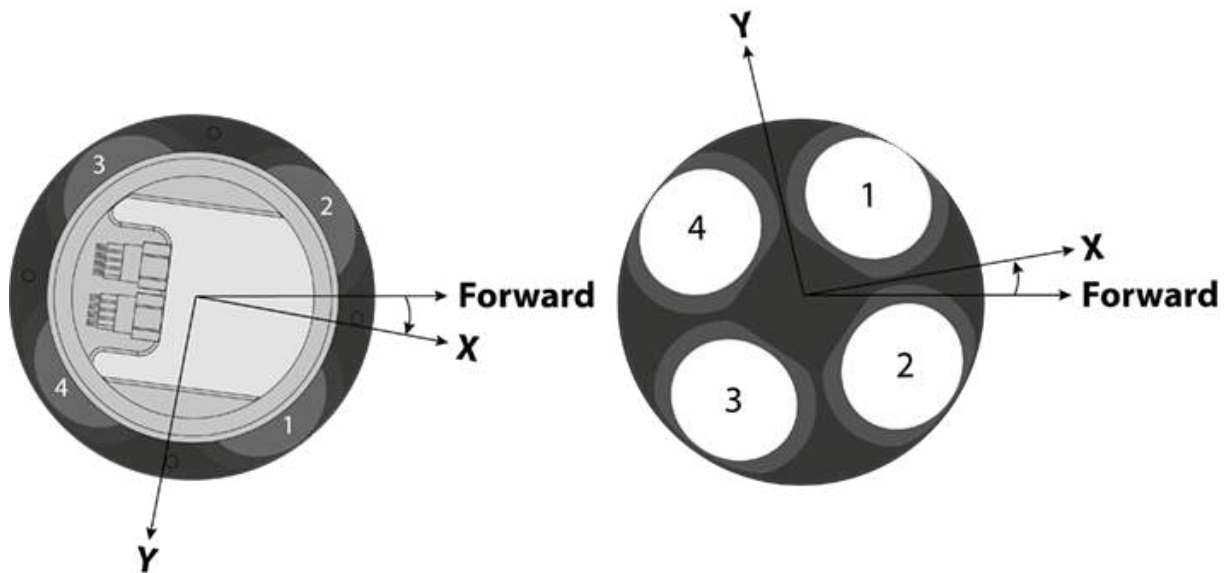

DVL Origin

Those requiring a reference origin for the DVL may use the figure below. This information is typically used for the lever arm calculations with an INS. All measurements are in mm. Please see appendix for generation 2 drawings.



6.5 Control and Timing

Nortek DVLs allow for external clock synchronization of millisecond precision through IEEE 1588/PTP. The time stamp for individual beams is provided with 1 millisecond resolution. Precision timing is yet another feature that permits high precision navigation.

Time of validity

The total time between the trigger and start of output message is separated into two sections, DT1 and DT2.

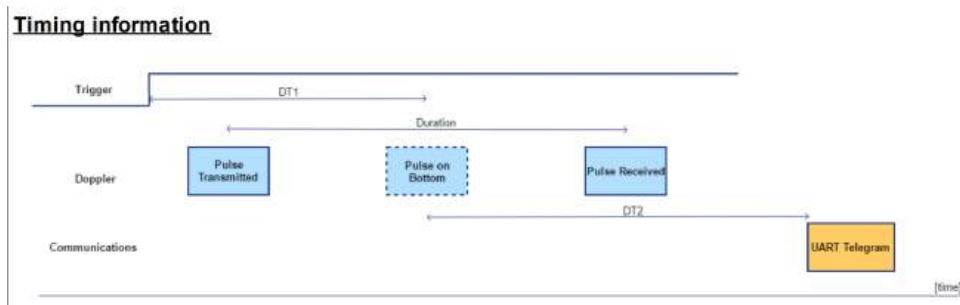

DT1 covers the period from the trigger until the middle of the pulse is on the bottom. DT2 starts with the middle of the pulse on the bottom until the start of the output message. This allows users to calculate the precise time the pulse was at the bottom (time of validity) using two different reference points.

6.6 Trigger

The trigger mode specifies what controls the acoustic pinging. This can be controlled through the instrument and its internal timing mechanism (INTSR), trigger from a command (SERIAL) or a hardware based trigger (TTL or RS485 input lines). The hardware triggers will be ignored if they occur at a faster rate than what is possible to process for the configured range.

Internal

1, 2, 3, 4, 5, 6, 7 or 8 Hz

Serial

Trigger option through command (Ethernet or serial)

External

TTL or 485 electrical interfaces.

Configurable trigger polarity (configurable Rising edge/Falling edge/Both edges)

Check out the [Integrators Interfaces](#) section for examples showing how to setup the instrument to use a specific trigger.

When triggered the instrument will perform a complete ping (Tx and Rx) before it goes back to monitoring the trigger. Any triggers asserted during an ongoing ping will be ignored.

- The pulse length should be minimum 1 ms.
- The latency (trigger to start of transmit pulse) is 8.4 ms

The length of the transmit pulse depends on the frequency of the DVL and the altitude above the bottom. Once the length of the pulse is determined, the transmit duration can then be calculated using the configured speed of sound in water (either user set or measured). **Note that all lengths are measured along the beam.**

- The transmit length for DVL 1000 is 10 meters when operating at an altitude of 20 meters or more. At altitudes less than 20 meters, the transmit length is half of the distance to the bottom.
- The transmit length for DVL 500 is 20 meters when operating at an altitude of 40 meters or more. At altitudes less than 40 meters, the transmit length is half of the distance to the bottom.
- The transmit length for DVL 333 is 30 meters when operating at an altitude of 60 meters or more. At altitudes less than 60 meters, the transmit length is half of the distance to the bottom.

6.7 DVL Configuration

Trigger Mode

The trigger mode specifies what controls the acoustic pinging. See above section for more details.

Sample Rate

The acoustic sampling rate of an instrument changes based on the configured range. The trigger frequency limit is derived from the speed of sound, distance traveled and the instrument's capabilities. Below are tables and graphs listing various potential ranges and their corresponding maximum trigger frequencies.

DVL 333	
Range (Meters)	Maximum trigger frequency (Hertz)
43	8
55	7
70	6
91	5
123	4
176	3
281	2
400	1

DVL 500	
Range (Meters)	Maximum trigger frequency (Hertz)
52	8
63	7
78	6
99	5
131	4
184	3
200	2

DVL 1000	
Range (Meters)	Maximum trigger frequency (Hertz)
60	8
72	7
79	6
80	5

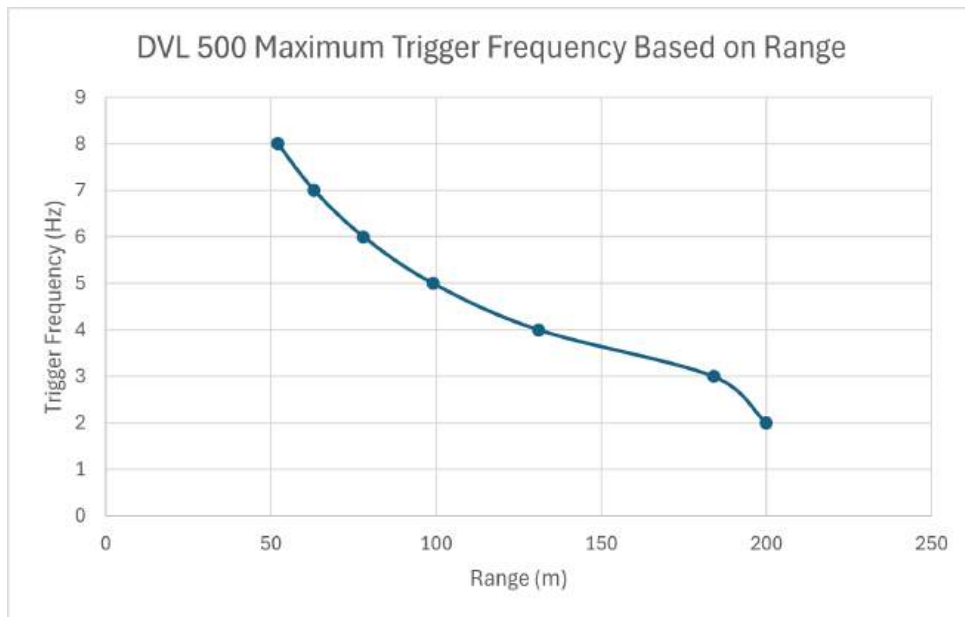
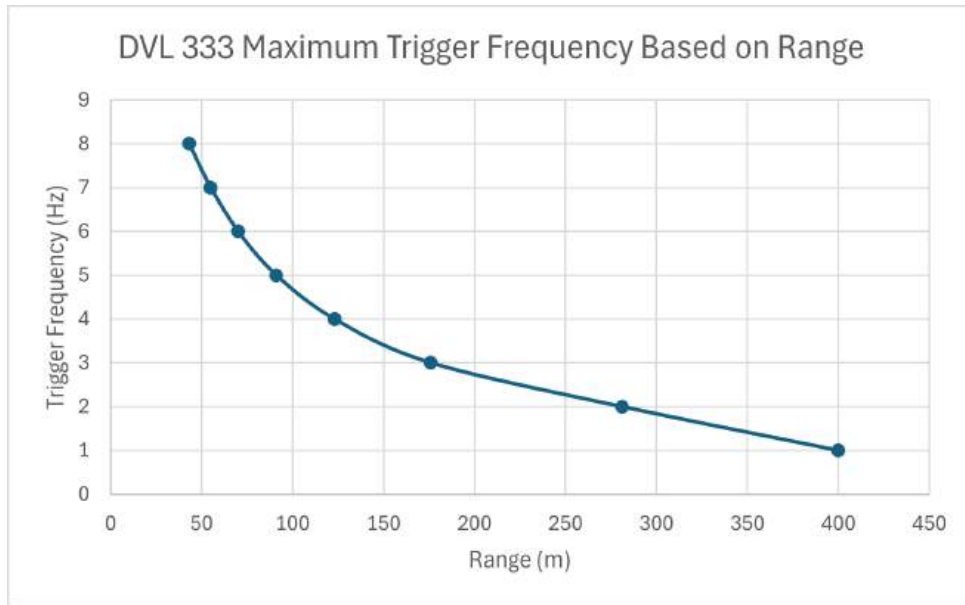

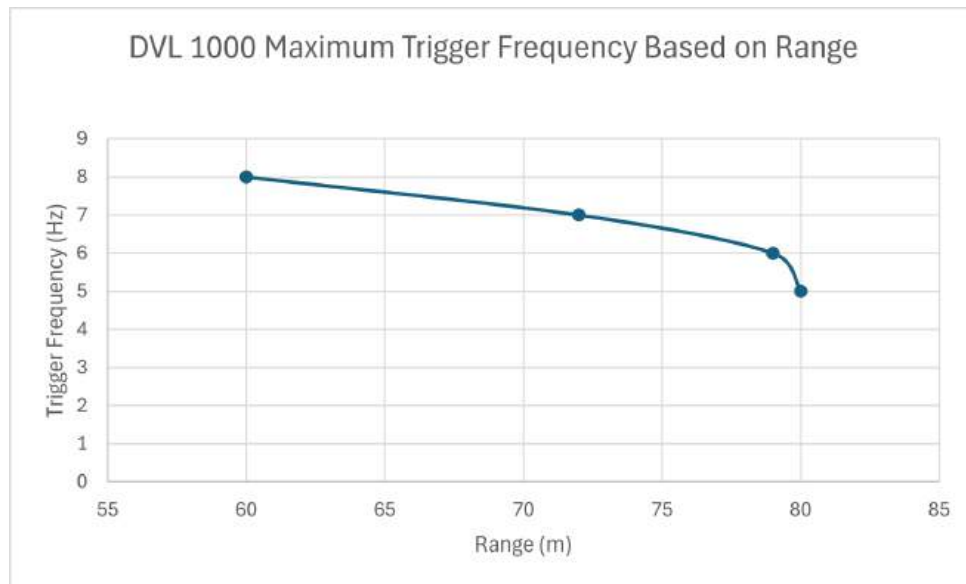

Speed of Sound

The speed that sound travels through the water is important for estimating velocity in the Doppler processing. The user may select between "Measured" which is estimated from the configured salinity, measured temperature and pressure or "Fixed" which is a fixed value. Users logging external speed of sound estimates who wish to apply linear corrections outside of the DVL estimation process should use the fixed setting.

Salinity

This is the estimated salinity (in parts per thousand) for the location the DVL will be operating. The typical value for sea water is 35 ppt. Configuration of this value is only relevant if the end user sets the speed of sound configuration to Measured.

Enable Data Recording

Check this box if you wish to log data to the internal SD memory card. Note that a file name must be set in order for the file to save to the internal SD card.

Enable Diagnostic Data Recording

Check this box if you wish to log diagnostic data to the internal SD memory card. Note that a file name must be set in order for the file to save to the internal SD card. Diagnostic data should only be logged by request of Nortek support.

Data Recording File Name

This is the name of the file for the data recording file. If the same name exists on the recorder then data is appended to the existing file. If the recorder gets full, the measurement continues but data is no longer stored to the recorder.

6.7.1 Bottom Track

Blanking Distance

The distance from the DVL where it begins to search for bottom.

Range

The maximum distance at which bottom is detected (along the DVL's Z-axis). The maximum range may be reduced if a high sample rate is selected (the new limits will then be shown after you click submit). If the vehicle is to operate in an environment with multiple reflections (e.g. shallow waters) it is recommended to set the range accordingly.

Transmit Power

The amount of acoustic energy that is output from the DVL. Lower power is sometimes desirable if there is an interest in reducing power consumption or if a short profile will be measured. The maximum power level is range dependent, so the user may either let the firmware select the maximum (MAX) given the current configuration or choose a value (USER). If USER is selected, a power level of 0 dB represents maximum power output. In some configurations, the maximum power is given as -2. Power is decreased by entering negative values. Configuring the transducers to -100 will completely disable the transducers.

Bottom Track Data

This is the data output (and recording if selected) format for the DVL's bottom track. The DF21 binary data format includes complete DVL data products, while variants of PD# are available for platforms limited to this legacy format. A complete description is found in the [Output Data Formats](#) section.

Water Track Data

This is the data output (and recording if selected) format for the DVL's water track. The DF22 binary data format includes complete DVL data products, while variants of PD# are available for platforms limited to this legacy format. A complete description is found in the [Output Data Formats](#) section.

	DF21	DF22	DF150 (PD0)	DF154 (PD4)	DF155 (PD5)	DF156 (PD6)
System Info	✓	✓		✓	✓	
Speed of sound	✓	✓	✓	✓	✓	✓
Temperature	✓	✓	✓	✓	✓	✓
Pressure (depth)	✓	✓	✓		✓	✓
Water velocity		✓	✓	✓	✓	✓
Bottom velocity (X,Y,Z)	✓		✓	✓	✓	✓
Distance to bottom	✓		✓	✓	✓	✓
Distance to measurement cell		✓				
Beam velocity	✓	✓				
Beam distance	✓	✓				
Time of trigger to center of echo (time of validity)	✓	✓				
Velocity uncertainty estimate (Figure of Merit)	✓	✓				

Enable Water Track

Check this box to enable velocity estimates relative to the water. Velocity estimates from Water Track (WT) are only available when the range along the beam is above the minimum (minimum range depends on the frequency of the unit). As range increases, the WT cell gets larger. The figures below describe where the water track cell starts and stops, based on the beam range. No measurements are made if the beam range is less than the minimum. As range increases, the start of the WT cell moves further from the DVL until it flattens out. A similar pattern is repeated for the end point of the WT cell.

Note: All distances displayed are along beam. To convert to vertical distance below DVL, use beam distance multiplied by $\cos(25)$.

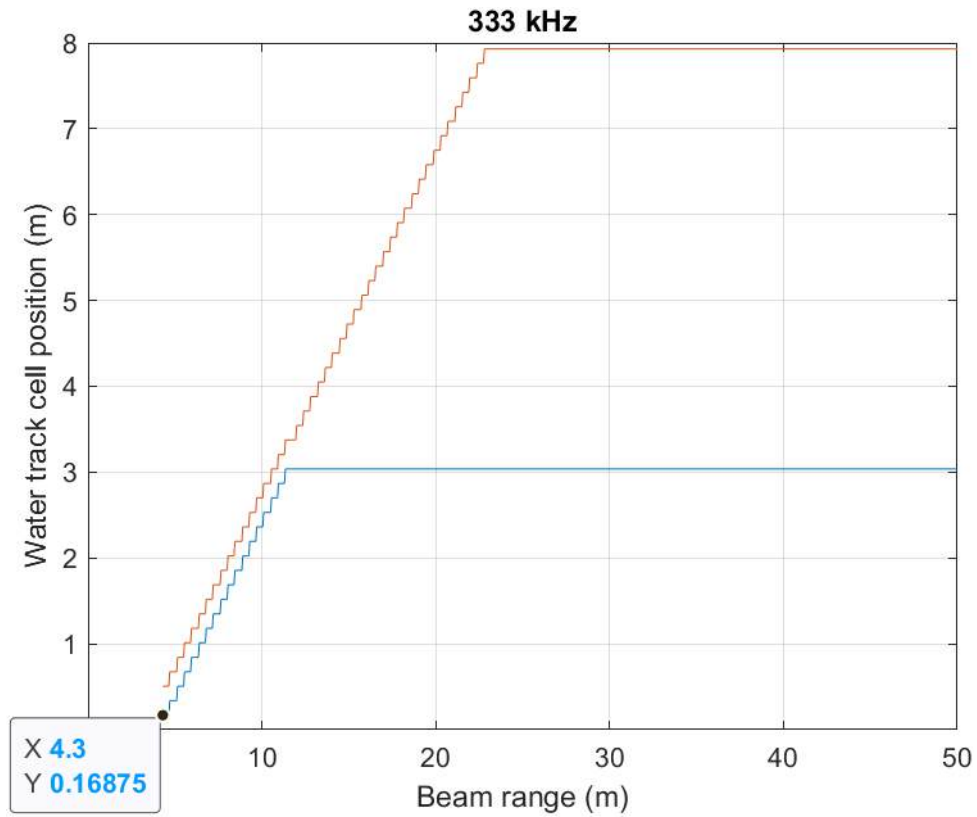

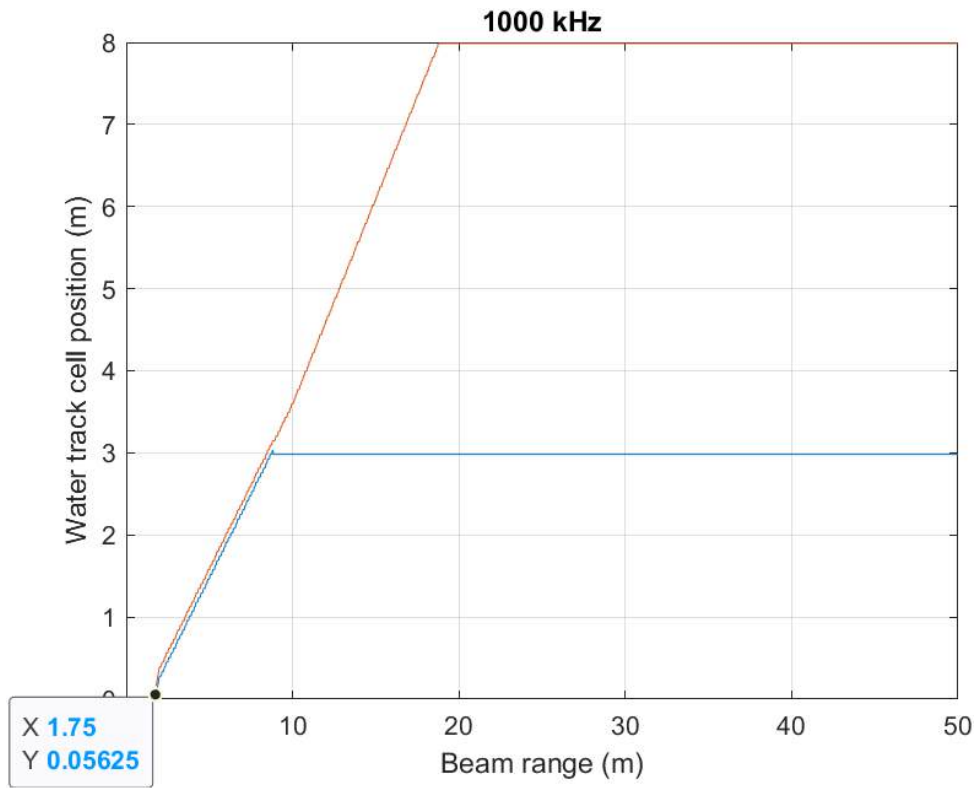
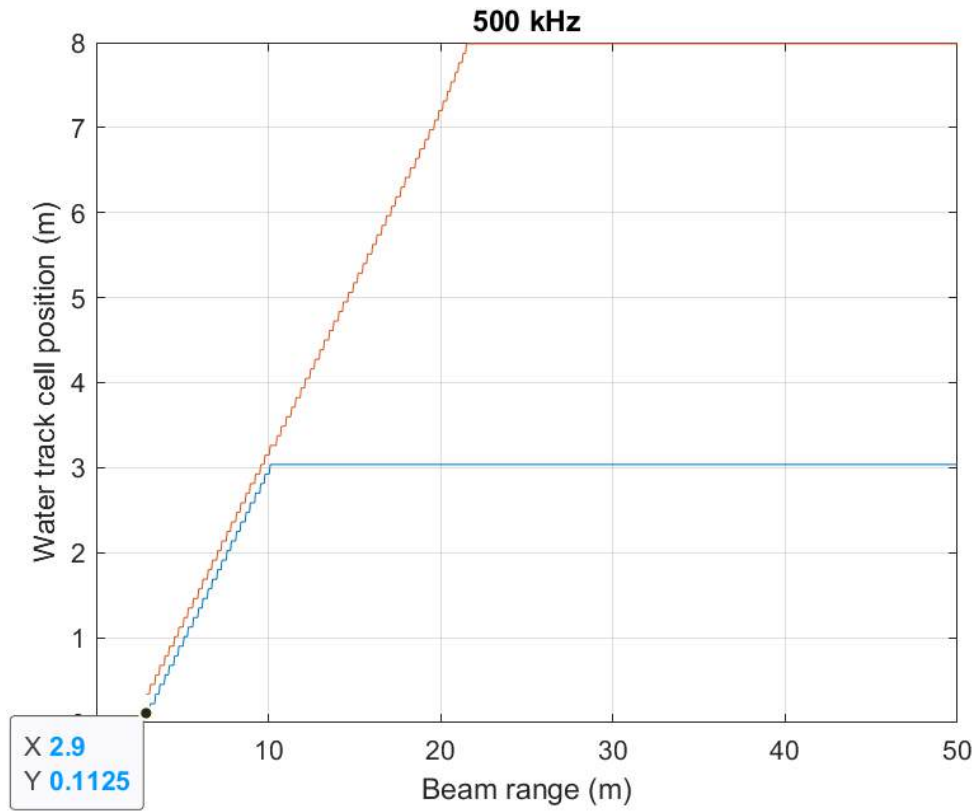

Bottom Track Modes

Bottom track detection has four different modes. They are as follows:

Normal mode

Intended for general DVL use. Permits full range of distances from the bottom as well as full range of velocities. Bottom track is established and output following a valid acquisition of 8 of last 10 pings from a minimum of three beams.

Crawler mode

A dedicated mode that uses a different acoustic transmission (two short pings in sequence). The crawler mode is for aiding vehicles that intend to operate in station keeping mode or move very slowly. The advantage of the Crawler mode is that it has lower uncertainty in the velocity estimates and allows for closer operation to the boundary. There are limitations in range and along beam velocity which are shown in the configuration limits when set to crawler mode. The minimum detectable distance is 10 cm and the maximum is 10 m, 20 m, and 30 m for 1000 kHz, 500 kHz and 333 kHz, respectively. The default velocity limit along beam is 0.15 m/s, which translates to a maximum in the horizontal, XY plane as 0.35 m/s; this may be adjusted with the bottom track velocity range. The horizontal velocity range is approximately 2.5 times greater than the beam velocity range. Bottom track estimates are not reported when the limits are exceeded. The maximum along beam velocity may be manually set to 0.4 m/s.

Auto mode

A hybrid of Normal and Crawler modes. As the name suggests, the DVL will automatically change between Normal and Crawler modes based on distance to the bottom and the measured velocity. In Auto mode, the DVL will switch to Crawler mode after a consistent detection of 10 consecutive pings with an along-beam velocity of 10 cm/s and a bottom distance below 7.5 m, 12.5 m and 17.5 m for frequencies 1000 kHz, 500 kHz, and 333 kHz, respectively. To cope with accelerations, the DVL will switch back to Normal mode on the first detection of an along-beam velocity above the 10 cm/s threshold. It will also switch back to normal mode after four consecutive missed detections or four detections above the before mentioned range limit.

Fast_Acq mode

This mode is similar to Normal mode but without an acquisition requirement to begin reporting bottom detections. It is also the bottom track legacy mode of the Nortek DVL. In this mode, any bottom track values will be reported without waiting to build up a confidence interval. Note that this mode exposes the DVL to a greater level of false detects.

6.7.2 Current Profiling

Enable Current Profiling

Check this box to enable current profiling. DVL must have a valid current profiling license to be enabled.

Interleave Ratio

This determines how frequently current profile data is measured (bottom track and current profiling do not operate concurrently). The ratio N, specifies that every Nth measurement is a current profile measurement. An interleave ratio of N=2 for example, will provide alternating pings between bottom track and current profiles whereas a ratio of N=3 will configure two consecutive bottom tracks measurements followed by one current profile measurement.

Cell Size

This is the size of the cell (along the DVL's Z-axis) for which velocity estimates are performed.

Blanking Distance

This is the distance from the DVL at which the current profile begins. Note that position of the first cell is the sum of the blanking distance and cell size. This follows standard ADCP principles.

Range to Last Cell

This is the distance along the DVL's Z-axis to the last measurement cell.

Velocity Range

This is the velocity range (positive and negative) along the beam axes to estimate currents. The corresponding horizontal velocity range is scaled the same way as the Bottom Track velocity range.

Transmit Power

This the amount of acoustic energy that is output from the DVL. Lower power is sometimes desirable if there is an interest in reducing power consumption or if the DVL will only be operating close to the bottom. The value of 0 dB represents maximum power output. Power is decreased by applying negative values.

Coordinate System

This specifies if the data is output in beam coordinates or the DVL's XYZ coordinates.

Data

Selects the data format for outputting current profile estimates. The DF3 data format is the most complete and efficient format while the PD0 is complete but contains irrelevant fields and thus consumes more space. NMEA formats are also available. A complete description is found in the [Output Data Formats](#) section.

6.7.3 Fast Pressure

Fast Pressure feature is a mode for enabling rapid data output from the integrated pressure sensor. Note that higher data rates do not impact the resolution of the individual pressure estimates.

Fast Pressure is enabled using commands only. Please see the [Commands](#) section for more information on how to add licenses and enable the feature.

6.7.4 Unique ID

Unique ID is an advanced capability for Nortek Doppler Velocity Logs (DVLs) that ensures reliable operation when multiple DVL-equipped platforms operate in close proximity. It prevents signal interference (cross talk) between instruments by assigning each DVL a unique coded pulse. Unique ID also allows users to combat spoofing attacks in a similar manner to how it prevents cross talk between other instruments. This feature is implemented in the instrument's firmware and activated via a license key. Please contact Nortek support for licensing and configuration information.

6.8 Installing DVL on Vehicle

Mechanical alignment

It is recommended to install the DVL so that the positive X-axis is inline with the vehicles forward direction. Please refer to [Coordinate System](#) section for more information on X-axis offsets.

Mounting isolation

For units with a titanium end bell, it's highly recommended to isolate the DVL from the vehicle frame to avoid galvanic corrosion. Nortek sells an insulating plate that can be used for this purpose. Isolation is not a concern for units with a plastic end bell.

Beam clearance

Ensure the main transducer beam zone and a cone of 15 degrees around it is clear from any physical obstacles. These will interfere with the acoustics and bias the measurements.

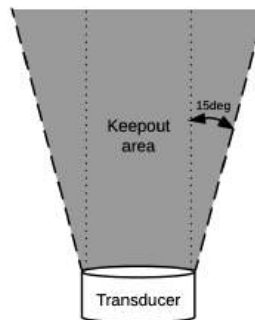

Calibration

No calibration of the DVL is required before installation. Once installed, the navigation system will require any heading misalignment between sensors to be addressed. Similarly, the scaling errors of the system and its mounting errors need to be addressed to ensure maximum accuracy. Please refer to your INS manual for calibration procedures.

7 Mechanical Aspects and Maintenance

Preventive maintenance is your primary tool to keep your instrument in good condition and ready for deployment. We recommend a regularly scheduled procedure which will act as a preventative measure to ensure your instrument continues functioning as intended. The following sections can be used as a maintenance guideline for the components that may be exposed to wear and tear.

We recommend conducting a 'Functionality Test' after any maintenance procedure has been completed to check functionality. We also recommend adding an entry in the internal log that is kept within the instrument. This can be helpful in assessing service intervals. The "Add Deployment Log Entry" box in the "Logs" tab of the web browser interface can be used to log a completed maintenance procedure. This log will also keep a record of things like formatting or erasing the recorder and firmware upgrades.

DO NOT EXPOSE THE ELECTRONICS

In general, there should be no reason to expose the instrument electronics. **Do not open the pressure housing unless instructed by Nortek.**

Only qualified personnel are allowed to perform corrective maintenance activities. Please [contact Nortek](#) for further assistance if in any doubt.

7.1 Instrument Care

All Nortek instruments are intended for use in water. Other fluids may have an adverse effect on the instrument.

Always use a dummy plug to seal any unused, open connectors.

A preventive maintenance routine should include regular cleaning of the instrument. Use a **mild** detergent and pay special attention to the transducers. Do not expose any part of the instrument to harsh chemicals.

Only fix/attach the instrument via the mounting holes.

Never open the instrument unless specifically directed to do so by Nortek staff. Opening the instrument without specific direction to do so from Nortek will void the warranty.

If the instrument has been subjected to environmental conditions outside the specified design limits (refer to the [Technical Specification](#) to check your instrument's limits), mechanical tolerances of non-metal components may be affected.

7.2 Connector Care

Follow these instructions carefully to ensure correct use of your SubConn connectors. Follow this link to MacArtney's website for more details:

[SubConn handling instructions](#)

Handling

- Connectors must be greased with MOLYKOTE® 44 Medium before every mating.
- Disconnect by pulling straight out, not at an angle.
- Do not pull on the cable and avoid sharp bends at cable entry.
- When using a bulkhead connector, ensure that there are no angular loads.
- SubConn connectors should not be exposed to extended periods of heat or direct sunlight. If a connector becomes very dry, it should be soaked in fresh water before use.
- All current ratings are based on the connector being submerged in water.
- The locking sleeve must be hand-tightened only.

Greasing and Mating

Greasing and mating above water (dry-mate)

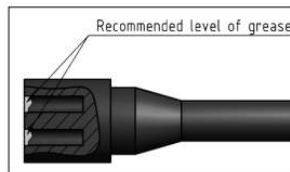

- Connectors must be greased with MOLYKOTE® 44 medium before every mating.
- A layer of grease corresponding to a minimum of 1/10 of the socket depth should be applied to the female connector.
- The inner edge of all sockets should be completely covered, and a thin layer of grease left visible on the face of the connector.
- After greasing, fully mate the male and female connector in order to secure optimal distribution of grease on all contacts and in the sockets.
- To confirm that grease has been sufficiently applied, de-mate and check for grease on every male contact. Then re-mate the connector.
- *General cleaning and removal of any accumulated contaminants on a connector should be performed using spray based contact cleaner (Isopropyl alcohol).

Cleaning Products



- * General cleaning and removal of any accumulated contaminants on a connector should be performed using spray-based contact cleaner (Isopropyl alcohol)
 - New grease must be applied again prior to mating
- Note: Acetone creates stress-induced cracking in PEEK material

Inline recommended bending radius

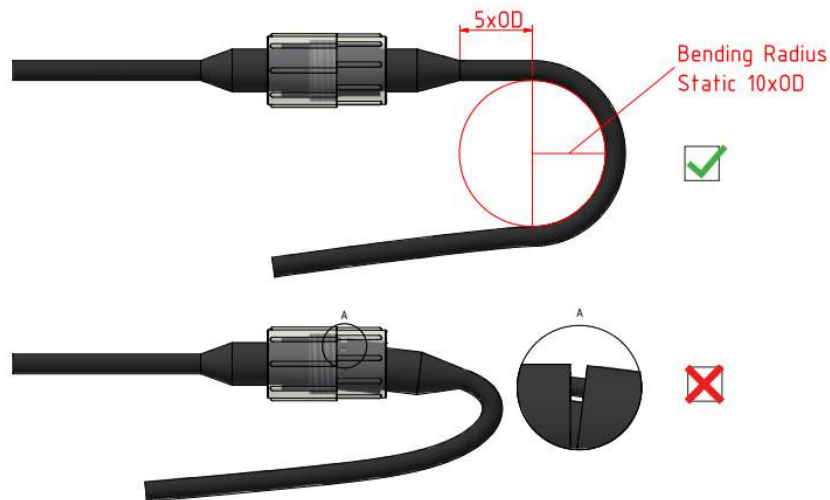

Connector Mating Force

Proper alignment of the connectors is vital to avoid damaging the sealing mechanism on the male connector. If excessive resistance is encountered when mating, stop and de-mate. Inspect for damage to connectors or obstructions in the female connector before attempting to re-mate.

Connector Compatibility

Ensure only genuine SubConn connectors are used on connecting cables. Nortek does not support the use of third party connectors as they can cause damage to sealing mechanisms, leading to flooding of the instrument.

7.3 Cable Care

To keep your cables in good condition:

- Avoid nicks and cuts around contacts, as these are the sealing surfaces.
- Do not pull on the cable to disconnect connectors; pull the connector itself.
- Avoid sharp bends near the cable entry to the connector.
- Ensure that the cable is fixed to the mounting fixture to avoid mechanical stress to the connection.
- Elastomers can be seriously degraded if exposed to direct sunlight or high ozone levels for extended periods. Avoid whenever possible.

8 Integrators Interfaces

The following sections are intended for system integrators. Please refer to the previous sections for information regarding DVL standard configuration and operating information.

8.1 Using the Command Interface

This section covers the commands that can be used to control an AD2CP instrument. Not every command will be appropriate for every instrument.

Some pointers:

- A configuration of the instrument should always start with setting the default configuration, e.g.:
`SETDEFAULT,CONFIG`
`OK`
- All command parameters should be set explicitly, e.g.:
`SETDVL,TRIG="TLRISE"`
`OK`
- Sometimes you may get an ERROR response after trying to save the configuration or start/deploy the instrument. This doesn't necessarily mean that something is wrong with the instrument, but is most often a sign that the configuration isn't going to work. Any ERROR response can be interrogated with `GETERROR`, e.g.:
`SAVE,CONFIG`
`ERROR`
`GETERROR`
`GETERROR,NUM=56,STR="Invalid setting: Avg Average Interval too low for the configured number of pings and profiling distance",LIM="GETAVG1LIM,AI=([360;1800])"`
`OK`

Here, the instrument is reporting that we have set the average interval to be too short, and it provides the limits for the AI (average interval) that are allowed if we are going to keep the same number of pings and profiling distance. You could increase the AI, decrease the number of pings, or decrease the profiling distance (i.e. number/size of cells) to fix the error.

Command Limit Formats

The limits for the various arguments are returned as a list of valid values, and/or ranges, enclosed in parenthesis (). An empty list, (), is used for arguments that are unused/not yet implemented. Square brackets [] signify a range of valid values that includes the listed values. String arguments are encapsulated with "", like for normal parameter handling. A semicolon, ;, is used as a separator between limits and values.

The argument format can also be inferred from the limits, integer values are shown without a decimal point, floating point values are shown with a decimal point and strings are either shown with the string specifier, "", or as a range of characters using ' ' for specifying a character.

Examples:

[1;128] – Integer value, valid from 1 to 128.

([1300.00;1700.00];0.0) – Floating point value, valid values are 0.0 and the range from 1300.00 to 1700.00.

(['0';'9'];['a';'z'];['A';'Z'];'.') – String argument with valid characters being . and the character ranges a-z, A-Z, 0-9.

("BEAM") – String argument with BEAM being the only valid string.

(0;1) – Integer value with two valid values, 0 and 1.

NMEA interface example:

`$PNOR,GETCURPROFLIM*7E`

`$PNOR,GETCURPROFLIM,NC=([1;200]),CS=([0.50;4.00]),BD=([0.50;68.00]),CY=("BEAM";"XYZ"),PL=([-20.0;0.0];-100.0),VP=(),VR=([1.00;5.00]),DF=(3;100;101;102;103;104;150),NB=([0;4]),CH=([0;4321])*2B
$PNOR,OK*2B`

Regular interface example:

`GETDVLLIM`

`(0;[2;20]),`

`("INTSR";"TTLEDGE";"TTLRISE";"TTLFALL";"RS485EDGE";"RS485RISE";"RS485FALL";"SERIAL"),`

`(1.0;2.0;3.0;4.0;5.0;6.0;7.0;8.0),(['0';'9'];['a';'z'];['A';'Z'];'_';'.'),([1300.00;1700.00];0.0),([0.0;50.0])`

`OK`

8.2 Basic Interface Concept

In addition to the traditional serial port interface for real time data output there are several options for communication over Ethernet. The Ethernet communication is handled by a dedicated processor in the instrument. This network processor runs a Linux operating system, which makes it possible to connect to the instrument via Telnet, raw connections and FTP. The network processor mainly provides Ethernet connectivity. The other processor in the instrument, called the Doppler processor, is where the commands end up and where they are used to perform the measurements as specified.

The Nortek DVL is based on the AD2CP hardware platform. It operates in distinct modes. These modes will have several explicit commands in order to control the instrument. The majority of the commands are initiated from the Command mode. The possible modes for the instrument are:

- Command - Command and control
- Data Retrieval - Data download from recorder
- Measurement - Data collection mode
- Confirmation - Confirmation mode

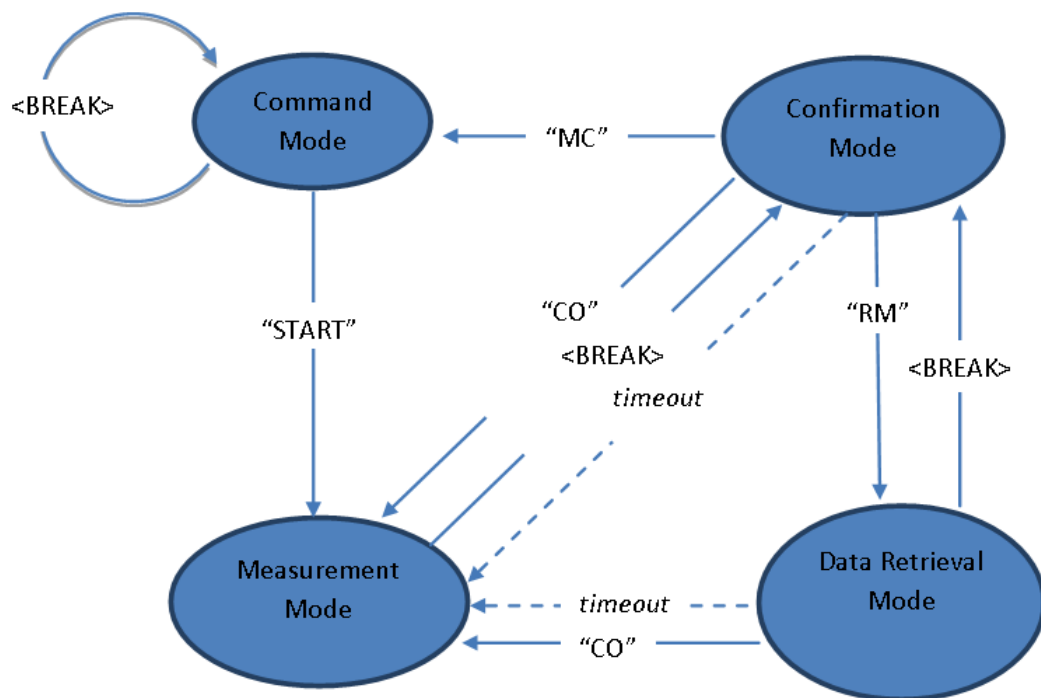

Instrument modes of operation

In measurement mode the DVL is always "awake" by default, and does not enter sleep mode. This is to significantly shorten the time it takes the DVL to respond to a trigger. The DVL can optionally be configured to sleep while waiting for a trigger, in the interest of saving power (see [SETDVL.FASTTRIG](#)).

Initializing communication with the instrument is performed by sending a `<BREAK>`, which is defined below. The `<BREAK>` will either set the instrument in Confirmation mode or restart Command mode. The

options for changing mode depends on the present mode of the instrument (see diagram above for clarity). The timeout shown in the diagram occurs if no commands are received in the various modes. A timer will then ensure that instrument operation continues. The timeout value in the Confirmation and Data Retrieval Modes is 60 seconds. There is also a timeout in Command Mode when operating over the serial interface. If no commands are received for 5 minutes, a break or a sequence of @@@@ must be sent to wake up the processor.

<BREAK> over the serial RS232/RS422 interface is defined as:

@@@@@ <delay 150 milliseconds> K1W%!Q <delay 400 milliseconds> K1W%!Q

The @@@@@ is used to wake up the processor when it is in sleep mode. The second sequence of the actual break characters is there to ensure that a break is detected even when the instrument is waking up due to some other cause (e.g. alarm from the real time clock). This ensures that the processor will interpret the following command correctly.

The figure and the table below show the specified timing of the <BREAK> sequence:

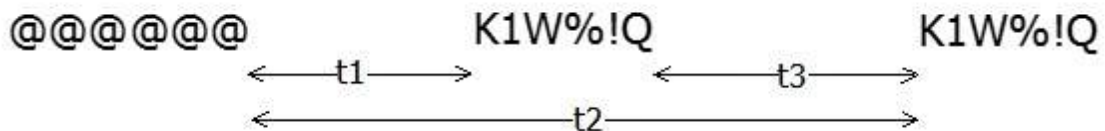

Symbol	Parameter	Min.	Typical	Max.	Unit
t1	Time from end of @-sequence to start of <i>first</i> K1W%!Q-sequence.	100	150		ms
t2	Time from end of @-sequence to start of <i>second</i> K1W%!Q-sequence.	500	1000	2000	ms
t3	Time between <i>first</i> and <i>second</i> K1W%!Q-sequence.	300	400		ms

Table 1: Timing of the <BREAK> sequence.

Default values are not listed for all commands in this document as some of them depend on the actual instrument in use. Default parameters can be retrieved by setting default configuration (**SETDEFAULT,CONFIG**) and reading out the desired parameter through the appropriate **GET** command.

The same can be said for some of the minimum and maximum values that depend on the actual instrument in use. The parameter range for the various arguments can be retrieved through the appropriate **GET[...].LIM** command, e.g. **GETDVLLIM,SR** to read the valid range of cell sizes.

All command parameters should be set explicitly, e.g.

SETDVL,SR=1.0,SA=35.0

OK

A configuration of the instrument should always start with setting the default configuration, e.g.

SETDEFAULT,CONFIG

OK

8.3 Command Interface

The command interface makes it possible to communicate with the DVL instrument using terminal software, the serial port and a set of commands. The interface is also available over Telnet. Some highlights:

- ASCII based and line oriented. Commands are terminated with CR/LF.
- Optional encapsulation of commands using NMEA style prefix and checksum to ensure data integrity.
- NMEA style commands will return argument names in their response.
- Argument limits can be retrieved through commands.
- Comprehensive validation and error handling is implemented.
- Invalid configurations return the erroneous argument with limits directly, so that each subsequent error can be handled until a valid configuration is achieved.
- A single command can be used to retrieve the complete configuration of the instrument with optional output to file.
- Commands to set default parameters.
- External controllers can use commands to store data in the raw data file (e.g. GPS position).

8.4 Ethernet Operation

The AD2CP uses TCP (transmission control protocol) for both command processing and data transmission. The Internet Protocol uses a combination of the IP address and port to uniquely identify a communications channel between two computers. For the AD2CP, different ports represent different means of communicating with the instrument. TCP ports 9001, 2002, 9004 are assigned for the following uses:

- Port 9000 is a telnet-protocol ASCII interface (require username / password authentication).
- Port 9001 is a raw (binary) interface (requires username / password authentication).
- Port 9002 is a binary data only channel (no input accepted).
- Port 9004 is an ASCII data only channel (no input accepted).
- Port 9010/9011 - Additional Output Data Format. See chapter [SETAODE](#).

The password entry is ignored if password authentication, as shown in the web page configuration, is disabled (so any input, including an empty password, is accepted). The command and data record formats for the interfaces are the same as for the serial port.

8.5 Telnet Connection

The telnet interface (TCP/IP port 9000) is used for user interaction with the instrument. This dedicated port can be used for entering commands and getting human readable responses (ASCII). The supported command set is available in the [Commands](#) section. The Windows telnet client can be used to connect into the instrument using the command line telnet ip_address 9000. You will get prompted for a username (nortek) and password (hit Enter if password protection hasn't been enabled via the Web Browser Interface).

Signature Username: nortek

Password:

Nortek Signature Command Interface

The interface is very similar to the direct serial interface over RS232/RS422 but some additions are made to simplify the interfacing. Most notable is the ability to send a <break> to the Doppler processor by just using Ctrl-C (ASCII 0x03). The internal application takes care of waking up the Doppler DSP and timing the delivery of the break string. The telnet server is not configured to echo characters, so users wishing to see and/or edit commands before sending them to the instrument should enable local echo and local line editing. If these features are desired, a telnet client capable of supporting local echo and local line editing must be used (e.g. PuTTY).

Port 9000 is dedicated for ASCII only communication whereas the ports described in the next section provide the complete set of data, including binary output of the measurements. A telnet client should not be used to access these ports. Read more about this in the next section.

To terminate the telnet connection, enter Ctrl-X (ASCII 0x18).

8.6 Raw Connections

A port can be understood as an address point between two communicating parts. When first connecting to a data listening port, the string "\r\nNortek name Data Interface\r\n" (name is replaced by the instrument host name) is sent to identify the instrument that has responded to the connection request.

TCP ports 9001, 9002 and 9004 are assigned for the following uses:

- Port 9001 is used for machine driven control. This port requires username/password. The serial port data is translated directly into TCP/ IP over Ethernet. Binary data generated in measurement mode is visible on this port. Standard streaming record delineation techniques must be used in order to make sure that the received data is properly synchronized for decoding. A break can be sent by sending the string K1W%!Q<CR><LF> to the instrument or a Ctrl-C character (ASCII 0x03) (Ctrl-C has to be sent on its own and not embedded in any command). The internal application takes care of the appropriate timing of the break sent over the internal serial port. This port require username / password authentication. Refer to previous section for examples. The password entry is ignored if password authentication, as shown in the web page configuration, is disabled (so any input, including an empty password, is accepted). The command and data record formats for the interfaces are the same as for the serial port.
- Port 9002 is a data only channel which will output all data that is configured for serial output. This can, for example, be used by display only software while configuration is done by another application.

- Port 9004 outputs ASCII data (no binary) that is configured for serial output.

A telnet client should not be used to access these ports. Telnet incorporates its own binary protocol which is neither interpreted nor sent via the raw connection. Using a telnet client on these ports will result in extraneous characters being sent and certain binary characters being interpreted by the client.

8.7 FTP

The internal data recorder is accessed over Ethernet using a standard FTP (File Transfer Protocol) client. FTP serves as a simple way to download measured data from the instrument.

When an FTP connection is active, the internal state of the machine is changed so that commands are no longer processed (and an error is returned when commands are entered). Terminating the FTP connection or sending a BREAK followed by the CO command will switch the instrument back to the mode it was in before the FTP session began. If a break command is sent while an FTP transaction is in progress, the FTP connection will be forcibly terminated.

If an FTP connection is done when the instrument is in measurement mode (see Figure 1), the FTP connection is made through data retrieval mode. When the FTP connection is terminated, the instrument will then return to measurement mode. If there is no data transferred or FTP commands sent for 120 seconds, the FTP connection will terminate and the instrument will return to measurement mode.

8.8 HTTP

HTTP (Hypertext transfer protocol) can also be used for data transmission. For organizations with strong security / firewall restrictions, FTP access to the instrument may not be permitted. For that reason, a web page allowing individual data files to be downloaded has been implemented in the Ethernet processor. The web page can be accessed by clicking on the "Data Download (HTTP)" link from the main web page.

8.9 UDP

UDP (user datagram protocol) can also be used for data transmission. When using UDP, the data collection software simply waits for data to be sent from the instrument without having to establish a connection first. This may be useful for cases in which instrument power is intermittently interrupted and re-connecting to the instrument is not desirable. One downside to UDP communications is that transmission of the data is not guaranteed. On a noisy / error-prone connection, it is possible that the occasional datagram may be dropped. If every data record must be received, then TCP is recommended.

Multicast operation is also supported over UDP if data should be distributed to multiple clients. This is enabled by entering an UDP address in the multicast address range.

In order to use UDP in a power-safe configuration, the IP address of the data collection software and port must first be configured using the web interface. The IP address identifies the client to which the data is to be sent and the port may be used to uniquely identify the instrument to the application. The same port may be used for all instruments if the data collection software examines the IP address of the received datagram to identify the instrument. Once this information has been configured, the Ethernet processor will automatically send real-time data records to the configured address / port. An instrument in measurement mode re-enters measurement mode shortly after a power-cycle, so the data collection software will immediately receive new data without having to re-establish a connection.

8.10 Time Synchronization

Time Synchronization allows the internal clocks used for data collection to be synchronized to an external source. Either NTP (Network Time Protocol) or PTP (Precision Time Protocol) can be selected.

Precision Time Protocol (IEEE-1588) is a standard used for distributing a high-resolution absolute time throughout an Ethernet network. The DVL can be configured to act as a slave to an existing PTP master clock (customer supplied) located in the same Ethernet LAN. The instrument contains a high-resolution clock which is synchronized and conditioned using PTP when enabled. The timestamps contained within the data records are then generated from this clock. When synchronized, these timestamps are typically aligned to within +/- 1 microseconds.

The PTP master clock must use UDP (layer three) and be configured for two-step operation with an end-to-end delay mode in order to be compatible with the DVL's PTP implementation. Using PTP does not affect the choice of UDP or TCP for the transport of data.

Network Time Protocol is a purely software based Internet time synchronization protocol. In comparison to PTP, NTP will typically take 1-2 minutes to fully achieve sync and will generally synchronize to within 1 ms for a local server. While there are no special requirements for the NTP time server in terms of hardware, synchronization is strongly affected by the network path between the server and the client and for that reason, it is strongly recommended that the NTP server be located on the same local Ethernet network as the instrument.

Setting up Time Synchronization

Setup through the web browser can be done by navigating to the Network Configuration tab. At the bottom of the page, locate the PTP IP address bar and enter the PTP address. Then click submit and observe the message window at the bottom of the page. Wait until the time sync is displayed before proceeding with any other changes or starting measurements. Note: If measurement mode is started or other configuration settings are changed before proper time sync is displayed in the message window, the PTP sync will be canceled and data collection will not occur.

Setup through a terminal is described in the [Commands](#) section. Note: If new commands are entered or the instrument is put into measurement mode before the sync is complete, the PTP sync will be canceled and data collection will not occur. Since there is no message window, it can be hard to tell when the PTP sync is complete. We recommend waiting 5 minutes after PTP sync is started to ensure the sync is complete. PTPGET can also be used to check PTP status.

8.11 Triggers

The DVL offers four main types of triggers: Internal Sampling, TTL trigger, RS-485 trigger and trig on command.

Internal Sampling (INTSR)

Sampling rates from 1 to 8 Hz are available. For long ranges the maximum sampling rate is reduced. The command GETMISCLIM,BTENDRANGE can be used to find the maximum range for the given sampling rate.

TTL Trigger

The DVL can be triggered on either Rising Edge, Falling Edge or Both Edges of a TTL Signal. When triggered, the instrument will perform a complete ping (Tx and Rx) before it goes back to monitoring the trigger. Any triggers asserted during an ongoing ping will be ignored. By default, the Fast Trigger option is enabled and the DVL does not sleep between pings, remaining fully powered. The alternative option is a power-saving trigger, where there is a partial power-down between pings (FASTTRIG=0).

The requirements for the TTL input is $V_{low} < 0.7 \text{ V}$ and $V_{high} > 2.5 \text{ V}$. The TTL input tolerates voltages between 0-5.5 V. The pulse length should be minimum 1 ms, the latency (trigger to start of transmit pulse with FASTTRIG disabled) is 8.3 ms, and the max length of the transmit pulse is 13.3 ms for the DVL1000, and 26.6 ms for the DVL333/DVL500. The actual length of the transmit pulse varies with the distance to the bottom.

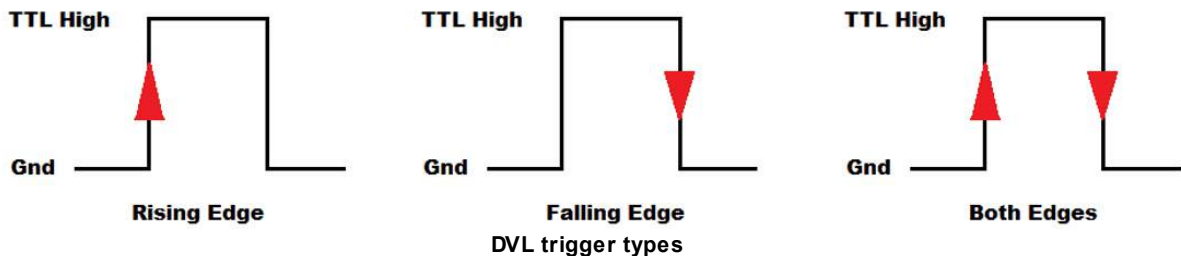

RS-485 Trigger

A RS-485 signal can be used to trigger the DVL. The DVL can trigger on either Rising Edge, Falling Edge or Both Edges of a RS-485 Signal. The following figure shows the polarities of the differential RS-485 signal pair for the trigger types. When triggered, the instrument will perform a complete ping (Tx and Rx) before it goes back to monitoring the trigger. Any triggers asserted during an ongoing ping will be ignored. The pulse length should be minimum 1 ms, the latency (trigger to start of transmit pulse with FASTTRIG disabled) is 8.3 ms, and the max length of transmit pulse is 13.3 ms for the DVL1000, and 26.6 ms for the DVL333/DVL500. The actual length of the transmit pulse varies with the distance to the bottom.

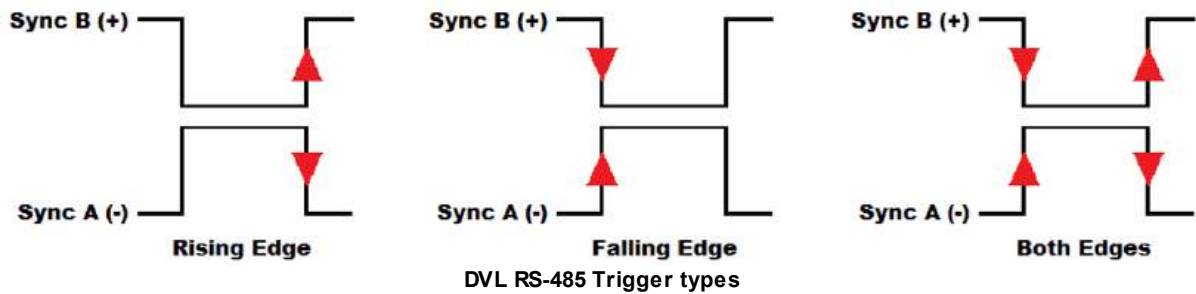

Trig on Command

When the TRIG parameter from the SETDVL command is set to "SERIAL" the DVL is triggered by sending a "TRIG[CrLf]" command. The trigger time will be when the end of the [CrLf] is received.

8.12 Example of Internal Trigger Command

Internal trigger at 4 Hz using measured sound velocity calculated using a salinity of 35.0 ppt. Velocity range 5 m/s along beam and a range of 10 meters:

(Since the instrument is in measurement mode, the first step is to get it into Command Mode)

Send Break

CONFIRM

MC

DVL - NORTEK AS.

Version 4041_10 (Nov 15 2017 14:38:16)

COMMAND MODE

OK

SETDEFAULT,CONFIG

OK

SETDVL,CP=0,TRIG="INTSR",SR=4.0,FN="",SV=0.0,SA=35.0

OK

SETBT,RANGE=10.00,VR=5.00,NB=4,CH=0,DF=21,PL=-2.0,WT="OFF",WTDF=22,BD=0.01,PLMODE="MAX"

OK

SAVE,CONFIG

OK

START

OK

8.12.1 Example of External Trigger Command

External, rising edge, TTL trigger using fixed sound velocity at 1500.0 m/s. Velocity range 2.5 m/s along beam and a range of 30 meters. This example also shows retrieval of argument limits and checking error conditions as the range is here first set erroneously to 100 meters: (Since the instrument is in measurement mode, the first step is to get it into Command Mode)

Send Break

CONFIRM

MC

DVL - NORTEK AS.

Version 4041_10 (Nov 15 2017 14:38:16)

COMMAND MODE

OK

SETDEFAULT,CONFIG

OK

GETDVLLIM,TRIG

("INTSR","TTLEDGE","TTLRISE","TTLFALL","RS485EDGE","RS485RISE","RS485FALL","SERIAL")

OK

SETDVL,CP=0,TRIG="TTLRISE",SV=1500.0

OK

SETBT,RANGE=100.00,VR=2.50,NB=4,CH=0,DF=21,PL=-
2.0,WT="OFF",WTDF=22,BD=0.02,PLMODE="MAX"

OK

SAVE,CONFIG

ERROR

GETERROR

261,"Invalid setting: Bottom track range invalid","SETBT,RANGE=([5.00;30.00])"

OK

SETBT,RANGE=30.0

OK

SAVE,CONFIG

OK

START

OK

9 Commands

This chapter contains an overview over all the commands, including a detailed description. Please refer to the previous chapter for examples, and how to use the commands.

9.1 List of Commands

Below is a list of all available commands with a short description and information about which mode they can be used in. For more information about each command see the following chapters. The arguments that can be used with each command are described in the respective chapter. Note that some of the commands requires at least one argument to be used.

Command	Description	Mode
BREAK	Wakes up the processor when it is in sleep mode	ALL
SETINST	Set instrument main settings	COMMAND
GETINST	Get instrument main settings	COMMAND
GETINSTLIM	Set instrument main setting limits	COMMAND
SETCLOCK	Set instrument clock	COMMAND RETRIEVAL
GETCLOCK	Get instrument clock	COMMAND RETRIEVAL
SETCLOCKSTR	Set instrument clock as string	COMMAND RETRIEVAL
GETCLOCKSTR	Get instrument clock as string	COMMAND RETRIEVAL
GETCLOCKSTRMS	Get instrument clock with milliseconds resolution as string	COMMAND RETRIEVAL
GETCLOCKMS	Get instrument clock with milliseconds precision	COMMAND RETRIEVAL
SETBT	Set bottom track settings	COMMAND
GETBT	Get bottom track settings	COMMAND
GETBTLIM	Get bottom track setting limits	COMMAND
START	Go to measurement mode.	COMMAND
SETDVL	Set dvl main settings	COMMAND
GETDVL	Get dvl main settings	COMMAND
GETDVLIM	Get dvl main setting limits	COMMAND
SETFASTPRESSURE	Set fast pressure settings	COMMAND
GETFASTPRESSURE	Get fast pressure settings	COMMAND

GETFASTPRESSURELIM	Get fast pressure setting limits	COMMAND
SETTRIG	Set trigger settings	COMMAND
GETTRIG	Get trigger settings	COMMAND
GETTRIGLIM	Get trigger setting limits	COMMAND
SETTRIG1	Set trigger settings for secondary plan	COMMAND
GETTRIG1	Get trigger settings for secondary plan	COMMAND
GETTRIGLIM1	Get trigger setting limits for secondary plan	COMMAND
READABSPRESSURE	Returns the absolute pressure reading from the instrument	COMMAND
SETCURPROF	Set current profile configuration	COMMAND
GETCURPROF	Get current profile configuration	COMMAND
GETCURPROFLIM	Get current profile configuration limits	COMMAND
SETALTI	Set altimeter configuration	COMMAND
GETALTI	Get altimeter configuration	COMMAND
GETALTILIM	Get altimeter configuration limits	COMMAND
SETUSER	Set instrument user settings	COMMAND
GETUSER	Get instrument user settings	COMMAND
GETUSERLIM	Get instrument calibration parameter limits	COMMAND
SETAODF	Set additional online data formats	COMMAND
GETAODF	Get additional online data formats	COMMAND
GETAODFLIM	Get available additional online data formats	COMMAND
ID	Get instrument Id	COMMAND
SETDEFAULT	Reload default settings	COMMAND
SAVE	Save settings for next measurement	COMMAND
MC	Go into command mode	CONFIRMATION
RM	Go into data retrieval mode	CONFIRMATION
CO	Go into measurement mode	CONFIRMATION RETRIEVAL
POWERDOWN	Set instrument in sleep mode	COMMAND
ERASE	Erase all files on the recorder	COMMAND
FORMAT	Format the recorder	COMMAND
READCFG	Read current configuration	COMMAND
INQ	Inquires the instrument state	COMMAND CONFIRMATION RETRIEVAL

		MEASUREMENT
GETERROR	Returns a full description of the last error condition to occur	COMMAND CONFIRMATION MEASUREMENT RETRIEVAL
GETERRORNUM	Returns a integer error value of the last error condition to occur	COMMAND CONFIRMATION MEASUREMENT RETRIEVAL
GETERRORSTR	Returns a string error description of the last error condition to occur	COMMAND CONFIRMATION MEASUREMENT RETRIEVAL
GETALL	Retrieves all relevant configuration information for the instrument	COMMAND
RECSTAT	Return recorder state	COMMAND RETRIEVAL
TAG	Write a Tag to output file and data output	COMMAND CONFIRMATION MEASUREMENT RETRIEVAL
PTPSET	Set precision time protocol parameters	COMMAND
PTPGET	Get precision time protocol parameters	COMMAND
GETHW	Returns hardware specifications	COMMAND CONFIRMATION MEASUREMENT RETRIEVAL
ADDLICENSE	Add license key	COMMAND
DELETELICENSE	Delete license key	COMMAND
LISTLICENSE	Lists all license keys in instrument	COMMAND

9.2 Wake processor from sleep mode

Command: BREAK

Command type: ACTION

Mode: ALL

Used to wake up the processor when it is in sleep mode.

The @@@@ are used to wake up the processor when it is in sleep mode since the instrument will only be able to monitor activity on the serial line when it sleeps. The second sequence of the actual break characters is there to ensure that a break is detected even when the instrument is

waking up due to some other cause (e.g. alarm from the real time clock). This ensures that the processor will interpret the following command correctly.

See more info on Break

Example:

```
@@@@@ <delay 100milliseconds> K1W%!Q <delay 300milliseconds> K1W
%!Q
```

9.3 Instrument main settings

Commands: SETINST, GETINST, GETINSTLIM,

Command type: CONFIGURATION

Mode: COMMAND

Instrument main settings

Argument	Description
BR	Baud Rate 300, 600, 1200, 2400, 4800, 9600, 19200, 38400, 57600, 115200, 230400, 460800, 625000, 1250000 Unit: [bit/s]
RS	Serial protocol 232, 422
LED	Enable/disable LED blink in head. When set to "ON24H" the LED will illuminate the first 24 hours of the measurement. "OFF": Turn LED Off "ON": Turn LED On "ON24H": Turn LED On for 24 hours
ORIENT	Sets the instrument orientation. Not used for DVL. "AUTOXUPDOWN": Auto X up/down "AUTOYUPDOWN": Auto Y up/down "AUTOZUPDOWN": Auto Z up/down "ZUP": Z up "ZDOWN": Z down "XUP": X up "XDOWN": X down "YUP": Y up "YDOWN": Y down "AHRS3D": The instrument will detect and change the orientation as the instrument is moved. Used if the instrument has an AHRS installed and does not have a constant defined UP direction
CMTOUT	Command mode timeout Unit: [s]

DMTOUT	Data retrieval mode timeout Unit: [s]
CFMTOUT	Confirmation mode timeout Unit: [s]

SETINST

Set instrument main settings

Example:

```
SETINST, LED="ON"
```

GETINST

Get instrument main settings

Example:

```
GETINST, BR=460800, RS=232, LED="ON", ORIENT="AUTOZUPDOWN", CMTOUT=300, D  
MTOUT=60, CFMTOUT=60
```

GETINSTLIM

Set instrument main setting limits

9.4 Clock settings

Commands: SETCLOCK, GETCLOCK,

Command type: CONFIGURATION

Mode: COMMAND, RETRIEVAL

Instrument Real Time Clock specified in date parts

Argument	Description
YEAR	The year, e.g. 2020 Values: [0; 9999]
MONTH	The number of month 1-12 (Jan = 1) Values: [1; 12]
DAY	The number day of month 1-31 Values: [1; 31]
HOUR	The hour of day 0-23 Values: [0; 23]

MINUTE	The minute of hour 0-59 Values: [0; 59]
SECOND	The second of minute 0-59 Values: [0; 59]

Note: Note that all parameters must be set when using the set command

SETCLOCK

Set instrument clock

Example:

```
SETCLOCK, YEAR=2020, MONTH=11, DAY=28, HOUR=13, MINUTE:15, SECOND=45
```

GETCLOCK

Get instrument clock

Example:

```
GETCLOCK
2022, 12, 13, 15, 24, 33
OK
```

9.5 Clock settings as strings

Commands: SETCLOCKSTR, GETCLOCKSTR,

Command type: CONFIGURATION

Mode: COMMAND, RETRIEVAL

Set or retrieve the Real Time Clock using a string. Must use the format as shown: yyyy-MM-dd HH:mm:ss

Argument	Description
TIME	Text string with this format yyyy-MM-dd HH:mm:ss (use UTC)

SETCLOCKSTR

Set instrument clock as string

Example:

```
SETCLOCKSTR, TIME="2020-11-12 14:27:42"
```

GETCLOCKSTR

Get instrument clock as string

Example:

```
GETCLOCKSTR, TIME
GETCLOCKSTR, TIME = "2014-11-12 14:27:42"
```

9.6 Get clock as string (with ms)

Command: GETCLOCKSTRMS

Command type: CONFIGURATION

Mode: COMMAND, RETRIEVAL

Retrieve the Real Time Clock using a string. Must use the format as shown: yyyy-MM-dd HH:mm:ss.sss

Argument	Description
TIME	Text string with this format yyyy-MM-dd HH:mm:ss.sss (use UTC)

Example:

```
GETCLOCKSTRMS
"2021-05-14 19:32:11.000"
OK
```

9.7 Get clock (with ms)

Command: GETCLOCKMS

Command type: CONFIGURATION

Mode: COMMAND, RETRIEVAL

Retrieve the Real Time Clock with milliseconds resolution. The API uses the Date() object. If this command is sent directly after an instrument reboot, there may be a delay up to 1 second before the response. Otherwise, the normal latency is below 10 ms. When comparing clocks over the serial interface, the receiving side should capture its local clock when start bit of the first character in the returned message is detected. This will ensure minimum latency between comparing the local clock with the instrument clock. Over an Ethernet interface, there will be some milliseconds latency using this method. To achieve the best precision in a system using Ethernet, PTP should be used, as described in the PTP section.

Argument	Description
YEAR	The year, e.g. 2020 Values: [0; 9999]

MONTH	The number of month 1-12 (Jan = 1) Values: [1; 12]
DAY	The number day of month 1-31 Values: [1; 31]
HOUR	The hour of day 0-23 Values: [0; 23]
MINUTE	The minute of hour 0-59 Values: [0; 59]
SECOND	The second of minute 0-59 Values: [0; 59]
MSEC	Milliseconds 0-999 Values: [0; 999]

Note: Note that all parameters must be set when using the set command

Example:

GETCLOCKMS

9.8 Bottom track settings

Commands: SETBT, GETBT, GETBTLM, GETBTFLIM,

Command type: CONFIGURATION

Mode: COMMAND

License: BottomTrack

The BT command configures the Bottom Track measurements and the Water Track measurements. The valid range for the various arguments should be verified using the GETBTFLIM command, also for the values listed here as they may change with firmware versions and instrument frequencies.

Argument	Description
RANGE	Maximum depth Unit: [m]
VR	Max velocity expected in the water column during deployment. Velocity range spans from -VR to +VR. Unit: [m/s]
NB	Select number of beams; 0 disables all beams. Maximum number of beams equals number of transducers on sensor head.
CH	Beam selection. E.g. CH=123 will enable beams 1, 2 and 3.
DF	Data format 21: Bottom Track Data Record version 1. 150: RDI PD0 - RDI documentation 154: RDI PD4 - RDI documentation 155: RDI PD5 - RDI documentation

	<p>156: RDI PD6 – RDI documentation. 350: NMEA \$PNORBT1 including tags. 351: NMEA \$PNORBT0 (same as DF350 but no tags) 354: NMEA \$PNORBT3 including tags. 355: NMEA \$PNORBT4 (same as DF354 but no tags) 356: NMEA \$PNORBT6 including tags. 357: NMEA \$PNORBT7 (same as DF356 but no tags) 358: NMEA \$PNORBT8 (sensors) including tags. 359: NMEA \$PNORBT9 (Sensors) (same as DF358 but no tags)</p>
PL	<p>Power level (range -20.0 dB to 0.0 dB, -100 dB to switch off transmit). This parameter is instrument dependent and dependent on the power consumption of the deployment as a whole. Unit: [dB] Values: [-20; 0]; -100</p>
WT	<p>Measure Water Track velocity ON, OFF</p>
WTDF	<p>Water Track Data format 22: Nortek DVL Water Track data format 150: RDI PD0 - RDI documentation 154: RDI PD4 - RDI documentation 156: RDI PD6 - RDI documentation 404: NMEA \$PNORWT3 including tags 405: NMEA \$PNORWT4 (same as DF404 but no tags) 406: NMEA \$PNORWT6 including tags 407: NMEA \$PNORWT7 (same as DF406 but no tags) 408: NMEA \$PNORWT8 (sensors) including tags 409: NMEA \$PNORWT9 (sensors) (same as DF408 but no tags)</p>
BD	<p>Blanking distance Unit: [m]</p>
PLMODE	<p>When set to Max the power level is always maximum. The User setting will use the value set with PL. MAX, USER</p>

Note: Note to powerLevelMode: Lower power is sometimes desirable if there is an interest in reducing power consumption or if the DVL will only be operating close to the bottom. The maximum power level is range dependent, so the user may either let the firmware select the maximum (MAX) given the current configuration or choose a value (USER). If USER is selected, a power level of 0 dB represents maximum power output. Power is decreased by entering negative values.

SETBT

Set bottom track settings

Example:

```
SETBT, RANGE=100.0
```

```
OK
```

GETBT

```
100.00,5.00,4,0,21,0.0,"ON",22,0.02,"MAX"  
OK
```

GETBT

Get bottom track settings

Example:

GETBT

```
70.00,5.00,4,0,21,0.0,"ON",22,0.02,"MAX"  
OK
```

GETBTLIM

Get bottom track setting limits

Example:

GETBTLIM

```
([2.00;200.00]),([5.00;5.00]),([0;4]),([0;4321]),  
(21;150;154;156;350;351;354;355;356;357;358;359),([-20.00;0.00]),  
("ON";"OFF"),(22;150;154;156;404;405;406;407;408;409),  
([0.02;10.00]),("USER";"MAX")  
OK
```

9.9 Start measurements

Command: START

Command type: ACTION

Mode: COMMAND

Go in measurement mode.

Note that the START command will save the configuration as well as starting the measurement, as if a SAVE,CONFIG command were sent.

Example:

START

OK

9.10 Dvl main settings

Commands: SETDVL, GETDVL, GETDVLIM,

Command type: CONFIGURATION

Mode: COMMAND

The DVL parameters specify which type(s) of measurements that will be measured and how the measurements are initiated/trigged.

Argument	Description
CP	Licensed feature. Collect Current Profile every Nth Bottom Track ping, 0 to disable Current Profile. 0, 2, 3, 4, 5, 6, 7, 8, 9, 10, 11, 12, 13, 14, 15, 16, 17, 18, 19, 20 Unit: [s]
TRIG	Specifies trigger type See integrators guide for a longer description on the triggers. "INTSR": Internal Sampling is available with rates from 1 to 8 Hz. For long ranges the maximum sampling rate is reduced. "TTLEDGES": TTL trigger on both rising- and falling edge of a TTL signal "TTLRISE": TTL trigger on rising edge of a TTL signal "TTLFALL": TTL trigger on falling edge of a TTL signal "RS485EDGES": Trigger on both edges of a RS-485 signal "RS485RISE": Trigger on rising edge of a RS-485 Signal "RS485FALL": Trigger on falling edge of a RS-485 Signal "SERIAL": When the TRIG parameter of the SETDVL command is set to "SERIAL" the DVL is trigged by sending a "TRIG[CrLf]" command. The trigger time will be when the end of the [CrLf] is received.
SR	Internal sampling rate if enabled. Unit: [Hz] Values: [0; 8]
FN	Filename Validation: 30 characters, a-z, A-Z, 0-9, . and _
SV	Sound velocity in surrounding medium 0 will set sensor to use measured sound velocity Unit: [m/s] Values: [1400; 1600]
SA	Salinity Unit: [ppt] Values: [0; 50]
ALTI	Licensed feature. Collect Altimeter ping every Nth Bottom Track ping. 0 to disable. 0, 2, 3, 4, 5, 6, 7, 8, 9, 10, 11, 12, 13, 14, 15, 16, 17, 18, 19, 20
FASTTRIG	If enabled, DVL does not sleep between pings. If disabled, there is a partial power-down between pings.
MODE	The bottom detection mode allows for four different options for detecting the bottom. For more details on choosing modes, see Modes in chapter on Operation Principles.

	<p>"NORMAL": For general DVL use.</p> <p>"CRAWLER": For aiding vehicles that intend to operate in station keeping mode or move very slowly.</p> <p>"AUTO": The DVL will automatically change between Normal and Crawler modes based on distance to the bottom as well as the measured velocity</p> <p>"FAST_ACQ": This mode is similar to Normal mode but it does not have an acquisition requirement to begin reporting bottom detection.</p>
--	--

SETDVL

Set dvl main settings

Example:

```
SETDVL, TRIG="TTLRISE"
OK
GETDVL
GETDVL, 0, "TTLRISE", 4.0, "", 0.0, 35.0, 0
OK
```

GETDVL

Get dvl main settings

Example:

```
GETDVL
GETDVL, 0, "INTSR", 4.0, "", 0.0, 35.0, 0
OK
```

GETDVLIM

Get dvl main setting limits

9.11 Fast pressure settings

Commands: SETFASTPRESSURE, GETFASTPRESSURE, GETFASTPRESSURELIM,

Command type: CONFIGURATION

Mode: COMMAND

License: FastPressure

Enables rapid pressure reading. The Fast pressure feature is a licensed mode for enabling rapid data output from the integrated pressure sensor. Note that higher data rates does not impact the resolution of the individual pressure estimates.

Argument	Description
EN	Enable/disable fast sampling of pressure. Default: 0
SR	Sampling rate if enabled. Values may be 10, 15 or 30 Hz 10, 15, 30 Unit: [Hz]
DF	Data format. 41: Binary format. Standard 10 byte binary header with ID = 0x41. Data part is only a 4-byte floating point number (float) giving the Depth below the Surface. 203: Standard depth below surface NMEA sentence.

SETFASTPRESSURE

Set fast pressure settings

Example:

```
SETFASTPRESSURE, EN=1, SR=15.0, DF=203
OK
```

GETFASTPRESSURE

Get fast pressure settings

Example:

```
GETFASTPRESSURE
GETFASTPRESSURE, EN, SR, DF
1, 15, 203
OK
```

GETFASTPRESSURELIM

Get fast pressure setting limits

Example:

```
GETFASTPRESSURELIM
GETFASTPRESSURELIM, (0;1), (10.0;15.0;30.0), (41;203)
OK
```

9.12 Trigger settings

Commands: SETTRIG, GETTRIG, GETTRIGLIM,

Command type: CONFIGURATION

Mode: COMMAND

The parameters and limits for Trigger. The available trigger types will depend on the harness/cable used with the instrument.

Argument	Description
EN	Enable/disable external trigger functionality.
TRIG	Specifies trigger type. The available trigger types will depend on the harness/cable used with the instrument. "TTLEDGES": Trigger on both rising- and falling edge of a TTL signal. "TTLRISE": Trigger on rising edge of a TTL signal. "TTLFALL": Trigger on falling edge of a TTL signal. "RS485EDGES": Trigger on both edges of a RS-485 signal. "RS485RISE": Trigger on rising edge of a RS-485 signal. "RS485FALL": Trigger on falling edge of a RS-485 signal. "COMMAND": Trigger on Command. When the TRIG parameter of the SETTRIG command is set to "COMMAND" the AD2CP is triggered by sending a "TRIG[CrLf]" command. The trigger time will be when the end of the [CrLf] is received
TRIGOUTPUT	TRIGOUTPUT=1 enables master trigger output. This enables several instruments to be synchronized together with one instrument acting as master. For an instrument to be used as a master when triggering, the trigger type needs to be set to RS485EDGES. Only continuous measurement configurations are supported in this mode, and all synchronized instruments must be on the same frequency and have the same deployment configuration.

SETTRIG

Set trigger settings

Example:

```
SETTRIG, EN=1, TRIG="RS485EDGES", TRIGOUTPUT=0
```

```
SETTRIG, EN=0, TRIG="INTSR", TRIGOUTPUT=1
```

GETTRIG

Get trigger settings

GETTRIGLIM

Get trigger setting limits

9.13 Trigger settings for secondary plan

Commands: SETTRIG1, GETTRIG1, GETTRIGLIM1,

Command type: CONFIGURATION

Mode: COMMAND

The parameters and limits for trigger for secondary plan. The available trigger types will depend on the harness/cable used with the instrument.

Argument	Description
EN	Enable/disable external trigger functionality. If EN=0 the internal Sampling is available with rates from 1 to 8 Hz. For long ranges the maximum sampling rate is reduced. If EN=1 the external sampling is enabled and given with the TRIG argument.
TRIG	Specifies trigger type and are given as counting numbers. The available trigger types will depend on the harness/cable used with the instrument. "TTLEDGES": Trigger on both rising- and falling edge of a TTL signal. "TLRISE": Trigger on rising edge of a TTL signal. "TLFALL": Trigger on falling edge of a TTL signal. "RS485EDGES": Trigger on both edges of a RS-485 signal. "RS485RISE": Trigger on rising edge of a RS-485 signal. "RS485FALL": Trigger on falling edge of a RS-485 signal. "COMMAND": Trigger on Command. When the TRIG parameter of the SETTRIG1 command is set to "COMMAND" the AD2CP is triggered by sending a "TRIG[CrLf]" command. The trigger time will be when the end of the [CrLf] is received
TRIGOUTPUT	TRIGOUTPUT=1 enables master trig output. RS485EDGE trigger must be used with this option. This enables several instruments to be synchronized together through RS485 with one of the instruments acting as master. Only continuous measurement configurations are supported in this mode, and all synchronized AD2CP instruments must be of the same frequency and have the same deployment configuration.

SETTRIG1

Set trigger settings for secondary plan

Example:

`SETTRIG1, EN=1, TRIG="COMMAND", TRIGOUTPUT=0`

GETTRIG1

Get trigger settings for secondary plan

GETTRIGLIM1

Get trigger setting limits for secondary plan

9.14 Read absolute pressure

Command: READABSPRESSURE

Command type: INFO

Mode: COMMAND

Returns the current absolute pressure measurement from the instrument in dBar.

Argument	Description
VAL	Absolute pressure value returned by the instrument. Unit: [dBar]

Example:

READABSPRESSURE

10.812

OK

9.15 Current profile settings

Commands: SETCURPROF, GETCURPROF, GETCURPROFLIM,

Command type: CONFIGURATION

Mode: COMMAND

License: CurrentProfile

The CURPROF command configures the optional Current Profile measurements.

The valid range for the various arguments should be verified using the GETCURPROFLIM command, also for the values listed here as they may change with firmware versions and instrument frequencies. Current profile always use a broad bandwidth.

The current profile functionality is licensed option and is noted in by the license field "AVERAGE MODE" in the license list when a GETALL command is issued. A single cell is made available when the end user would like to perform a functionality test of the transducers (See DVL Operations Manual).

The current profile is not the same as Water Track; Water Track is always available with each Bottom Track ping.

Argument	Description
NC	Number of cells Values: [1; 200]
CS	Cell size Unit: [m] Values: [0.5; 4]
BD	Blanking distance Unit: [m] Values: [0.5; 68]
CY	Co-ordinate system BEAM, XYZ
PL	Power level (range -20.0 dB to 0.0 dB, -100 dB to switch off transmit). Unit: [dB] Values: [-20; 0]; -100
VR	Velocity range along beam Unit: [m/s] Values: [1; 5]
DF	Data format 3: Nortek Binary format 6: ?? 100: Prolog NMEA format 101: NMEA format 1 102: NMEA format 2 103: NMEA format 3 104: NMEA format 4 150: RDI PDO, see RDI documentation
NB	Number of beams. Select number of beams. Maximum number of beams equals number of transducers on sensor head.
CH	Beam selection. E.g. CH=123 will enable beams 1, 2 and 3.

Note: The actual valid range for the various parameters for the firmware version is used can be found by using the GETCURPROFLIM command. This command has the same arguments as the SETCURPROF/GETCURPROF commands shown in the list above. The output format for limits is described in Data Limit Formats.

SETCURPROF

Set current profile configuration

GETCURPROF

Get current profile configuration

GETCURPROFLIM

Get current profile configuration limits

9.16 Altimeter settings

Commands: SETALTI, GETALTI, GETALTILIM,

Command type: CONFIGURATION

Mode: COMMAND

License: Altimeter

The altimeter is an optional hardware configuration available for select Nortek custom DVLs. The ALTI command configures the optional Altimeter measurements, and is enabled with the SETDVL command. The valid range for the various arguments should be verified using the GETALTILIM command., also for the values listed here as they may change with firmware versions and instrument frequencies.

Argument	Description
BD	Blanking distance Unit: [m] Values: [0.5; 5]
RANGE	Range Unit: [m] Values: [1; 175]
PL	Power level (range -20.0 dB to 0.0 dB, -100 dB to switch off transmit). Unit: [dB] Values: [-20; 0]; -100
DF	Data format 8: Nortek Data Format 8

Note: The actual valid range for the various parameters for the firmware version is used can be found by using the GETALTILIM command. This command has the same arguments as the SETALTI/GETALTI commands shown in the list above. The output format for limits is described in Data Limit Formats.

SETALTI

Set altimeter configuration

GETALTI

Get altimeter configuration

GETALTILIM

Get altimeter configuration limits

9.17 Instrument user settings

Commands: SETUSER, GETUSER, GETUSERLIM,

Command type: CONFIGURATION

Mode: COMMAND

The SAVE,USER command must be sent to save changes in USER parameters.

Argument	Description
POFF	Set the offset value of the pressure sensor. Unit: [dbar] Values: [0; 11]
ROTXY	Alignment offset. Equivalent to the Webpage Mounting Angle Unit: [deg] Values: [-180; 180]
MA11	
MA12	
MA13	
MA21	
MA22	
MA23	
MA31	
MA32	
MA33	

Note: A rotation of the XY coordinate system (about the z-axis) can be done using the ROTXY parameter.

The new coordinate system X'Y'Z' is given by the following:

$$[X'Y'Z'] = [[\cos(\text{rotxy}), -\sin(\text{rotxy}), 0], [\sin(\text{rotxy}), \cos(\text{rotxy}), 0], [0, 0, 1]] * [X, Y, Z]$$

SETUSER

Set instrument user settings

Example:

```
SETUSER, ROTXY=15.0
```

```
OK
```

```
SAVE, USER
```

```
OK
```

GETUSER

Get instrument user settings

GETUSERLIM

Get instrument calibration parameter limits

9.18 Additional online data formats

Commands: SETAODF, GETAODF, GETAODFLIM,

Command type: CONFIGURATION

Mode: COMMAND

The additional online data formats provide a means of producing two independent data streams with user selectable data formats that are different from those used in the main stream (e.g. the main stream could contain Nortek formatted data while the AODF streams could contain PDx formatted data). These two data streams (AODFA and AODFB) are only available when Ethernet is used for communications. The streams can be read from a client computer by either connecting to the associated instrument TCP/IP port (9010 for AODFA and 9011 for AODFB) or by configuring and enabling the associated UDP/IP data client information for the stream.

Each stream (AODFA/AODFB) can contain Bottom Track, Water Track, Current Profile and/or Altimeter data with the selected format. If UDP transmission is selected and configured, the instrument will automatically transmit UDP data records to the client address / port as it is received.

Argument	Description
DFBTA	AODFA – Data format for Additional Bottom Track Data
DFWTA	AODFA – Data format for Additional Water Track Data
DFCPA	AODFA – Data format for Additional Current Profile Data
DFALTIA	AODFA – Data format for Additional Altimeter Data
DFBTB	AODFB – Data format for Additional Bottom Track Data
DFWTB	AODFB – Data format for Additional Water Track Data
DFCPB	AODFB – Data format for Additional Current Profile Data
DFALTIB	AODFB – Data format for Additional Altimeter Data
DFBTRS	AODFRS – Data format for Additional Bottom Track Data
DFWTRS	AODFRS – Data format for Additional Water Track Data
DFCPRS	AODFRS – Data format for Additional Current Profile Data
DFALTIRS	AODFRS – Data format for Additional Altimeter Data

SETAODF

Set additional online data formats

GETAODF

Get additional online data formats

GETAODFLIM

Get available additional online data formats

9.19 Get instrument ID

Command: ID

Command type: INFO

Mode: COMMAND

Commands for accessing instrument name and serial number

Argument	Description
STR	Instrument name Values: '_' Max Length: 64
SN	Serial number Values: [0; 2147483647]

Example:

```
ID
"Signature1000",900002
ID,STR
"Signature1000"
```

9.20 Reload default settings

Command: SETDEFAULT

Command type: ACTION

Mode: COMMAND

Reload default settings.

Argument	Description
CONFIG	Restore all settings below except USER and INST to default values. Legacy argument ALL acts as CONFIG.
CP	Restore Current Profiling Mode Settings (CURPROF) to default.

INST	Restore instrument main settings to default.
BT	Restore bottom track settings to default.
USER	Restore user calibration to default.
DVL	Restore DVL settings to default.

Example:

```
SETDEFAULT, CONFIG
```

9.21 Save settings**Command:** SAVE**Command type:** ACTION**Mode:** COMMAND

Save current settings for next measurement. At least one argument must be specified for the SAVE command.

Argument	Description
CONFIG	Save all settings except INST and USER settings. Legacy argument ALL acts as CONFIG.
CP	Save Current Profiling Mode Settings (CURPROF).
INST	Save INST settings.
USER	Save user instrument settings.
BT	Save bottom track settings.
DVL	Save DVL settings.

Example:

```
SAVE, CONFIG
```

9.22 Enter command mode**Command:** MC**Command type:** ACTION**Mode:** CONFIRMATION

Sets instrument in command mode from confirmation mode.

Example:

```
MC
```

9.23 Data retrieval mode

Command: RM

Command type: ACTION

Mode: CONFIRMATION

Go into data retrieval mode from confirmation mode and access the instruments recorder.

Example:

RM

9.24 Enter measurement mode

Command: CO

Command type: ACTION

Mode: CONFIRMATION, RETRIEVAL

Continue in measurement mode from confirmation mode or data retrieval mode. Instrument returns to collecting data according to the current configuration.

Example:

CO

9.25 Power down

Command: POWERDOWN

Command type: ACTION

Mode: COMMAND

Power down the instrument to set it in sleep mode.

Example:

POWERDOWN

9.26 Erase files on recorder

Command: ERASE

Command type: ACTION

Mode: COMMAND

Erase all files on the recorder

Argument	Description
CODE	Code should be 9999

	9999
--	------

Example:

```
ERASE, CODE=9999
```

9.27 Format recorder

Command: FORMAT

Command type: ACTION

Mode: COMMAND

Format the recorder. Note that this can take minutes depending on the recorder size.

Argument	Description
CODE	Code should be 9999 9999

Example:

```
FORMAT, CODE=9999
```

9.28 Read configuration

Command: READCFG

Command type: CONFIGURATION

Mode: COMMAND

Read current configuration. If a filename parameter is given the current configuration is stored to a file. If no parameter is given the current configuration is written to console.

The output of this command can be used to configure the instrument to a known configuration.

Argument	Description
FN	Write the output to file. Values: ['a'; 'z']; ['A'; 'Z']; ['0'; '9']; '_' Max Length: 30

Example:

```
READCFG
```

```
SETDEFAULT, CONFIG
```

```
SETDVL, CP=8, TRIG="INTSR", SR=8.0, FN="", SV=0.0, SA=35.0
```

```
SETCURPROF, NC=60, CS=0.50, BD=0.10, CY="XYZ", PL=0.0, VP=0.000, VR=2.50, D  
F=3, NB=4, CH=0
```

```
SETBT, RANGE=30.00, VR=5.00, NB=4, CH=0, DF=21, PL=-
```

```
2.0, WT="ON", WTDF=22, BD=0.01, PLMODE="MAX"
```

```
SAVE, CONFIG
```

OK

9.29 Inquire state

Command: INQ

Command type: INFO

Mode: COMMAND, CONFIRMATION, RETRIEVAL, MEASUREMENT

The INQ command queries the instrument state. Note that when operating over RS232 or RS422 serial lines, it should be preceded with @@@@ <delay 400ms> and a flush of the input buffer in case the instrument is in power down or in a low power mode taking measurements.

Consult section "Modes" for a description of the Instrument modes.

Note: Parameters used to represent instrument mode:

0000: Bootloader/Firmware upgrade

0001: Measurement

0002: Command

0004: Data Retrieval

0005: Confirmation

0006: FTP-mode

Example:

(In command mode)

INQ

0002

(In measurement mode)

INQ

0001

(In confirmation mode)

INQ

0005

(In data retrieval mode)

INQ

0004

(In firmware upgrade mode)

INQ

0000

9.30 Get error

Command: GETERROR

Command type: INFO

Mode: COMMAND, CONFIRMATION, MEASUREMENT, RETRIEVAL

GETERROR retrieves a full description of the last error condition to occur. The error number is returned first followed by a string with the text description of the last error condition. A second string is also returned which contains information on the valid range of the failing argument.

Argument	Description
NUM	Integer error value
STR	Text description
LIM	Valid limits as text

Example:

```
SETDVL, sa=90.0
```

```
OK
```

```
SAVE, CONFIG
```

```
ERROR
```

```
GETERROR
```

```
310, "Invalid setting: DVL Salinity", "GETDVL LIM, SA=([0.0;50.0])"
```

```
OK
```

9.31 Get error number

Command: GETERRORNUM

Command type: INFO

Mode: COMMAND, CONFIRMATION, MEASUREMENT, RETRIEVAL

GETERRORNUM retrieves the integer error value for the last error condition.

9.32 Get error string

Command: GETERRORSTR

Command type: INFO

Mode: COMMAND, CONFIRMATION, MEASUREMENT, RETRIEVAL

GETERRORSTR retrieves the string description for the last error condition.

9.33 Get all

Command: GETALL

Command type: INFO

Mode: COMMAND

GETALL retrieves all relevant configuration information for the instrument. This information can either be displayed on the command line or saved to a data file on the instrument. For the Nortek post-processing software to read a valid Nortek file it must contain both the Header and Data Record. The Header information can be obtained by using the command GETALL.

Argument	Description
FN	Write the output to this file saved on instrument

Example:

GETALL

```

GETCLOCKSTR,"2016-03-11 08:31:13"
ID,"NortekDVL",200012
GETHW,4033,159,"H-0","D-0","C-4","D-0",19,1
BOARDSSENSGET,3,4,1000,2.0000,0.0000
GETDVL,0,"INTSR",8.0,"",0.0,35.0
GETBT,30.00,5.00,4,0,21,-2.0,"OFF",22,0.01,"MAX"
GETXFBT,4,4,0.836579,0.836579,-0.836579,-0.836579,0.836579,-
0.836579,-
0.836579,0.836579,0.551689,0.000000,0.551689,0.000000,0.000000,0.55
1689,0.000000,0.551689
GETUSER,9.50,0.000,1.000,0.000,0.000,0.000,1.000,0.000,0.000,0.000,
1.000
GETINST,9600,232,"ON","AUTOZUPDOWN",300,60,60
GETCOMPASSCAL,199,-33,68,29794,-512,-215,637,29296,79,7,-136,32767
BEAMCFGLIST,1,25.00,45.00,1000,25,1,1,60.00
BEAMCFGLIST,2,25.00,-45.00,1000,25,1,2,60.00
BEAMCFGLIST,3,25.00,-135.00,1000,25,1,3,60.00
BEAMCFGLIST,4,25.00,135.00,1000,25,1,4,60.00
BEAMIMPLIST,1,1.00000e+02,0.00000e+00,0.00000e+00,0.00000e+00,0.000
00e+00,0.00000e+00
BEAMIMPLIST,2,1.00000e+02,0.00000e+00,0.00000e+00,0.00000e+00,0.000
00e+00,0.00000e+00
BEAMIMPLIST,3,1.00000e+02,0.00000e+00,0.00000e+00,0.00000e+00,0.000
00e+00,0.00000e+00
BEAMIMPLIST,4,1.00000e+02,0.00000e+00,0.00000e+00,0.00000e+00,0.000
00e+00,0.00000e+00
LISTLICENSE,"LR9UFYGLM518D","Averaging Mode",1
LISTLICENSE,"KKEXGJ74M518D","Burst Mode",2
LISTLICENSE,"YGD79C6Z38Y0B","Bottom Track",3
OK
    
```

9.34 Get recorder state

Command: RECSTAT

Command type: INFO

Mode: COMMAND, RETRIEVAL

Returns recorder state.

Argument	Description
SS	Number of bytes in a sector. Unit: [bytes]
CS	Number of bytes in one cluster. Unit: [bytes]
FC	Number of bytes in free clusters. Unit: [bytes]
TC	Total number of bytes in clusters. Unit: [bytes]
VS	Volume Size in bytes. Unit: [bytes]
FF	Number of free files.
TF	Total number of files.
PNM	SD card type and firmware

Example:

```
RECSTAT, VS
```

9.35 Write tag output

Command: TAG

Command type: ACTION

Mode: COMMAND, CONFIRMATION, MEASUREMENT, RETRIEVAL

Write a Tag to output file and data output.

The TAG command adds a tag to the both the output file and the output data, if enabled. The output is a String Record as defined in the FWRITE command. The ID of the String Record Data packet is 19dec.

Argument	Description
STR	Tag string. Maximum 200 bytes.
CLK	Add clock in tag.

Note: Remember to use the BBPWAKEUP command when sending commands to an instrument in Measurement mode, when using Ethernet.

Example:

```
TAG, STR="This is a test tag.", CLK=1
a5 0a a0 10 2f 00 42 8c 42 5d 13 32 // Binary header
```

```
30 31 37 2d 30 31 2d 32 34 20 30 38 // String Record ID = 19dec
3a 34 32 3a 35 37 2e 34 34 39 20 2d // "2017-01-24 08:42"
20 54 68 69 73 20 69 73 20 61 20 74 // ":57.449 - This i"
65 73 74 20 74 61 67 2e 00 // "s is a test tag."
OK
```

9.36 Precision time protocol

Commands: PTPSET, PTPGET,
Command type: CONFIGURATION
Mode: COMMAND

Configure the precision time protocol parameters.

Argument	Description
EN	Choose a time protocol. 0: Time protocol disabled. 1: Use precision time protocol (PTP). 2: Use network time protocol (NTP).
OFFSET	Offset Unit: [μ s]
CL	Time value representing the number of seconds elapsed since 00:00 hours, Jan 1, 1970 UTC Unit: [s]
IP	The numeric IP address of the NTP server to use for syncing

Note: For the case of NTP, the instrument is not capable of DNS name resolution. In order to retrieve the IP address associated with a name, use the "nslookup" tool from the computer command line

PTPSET

Set precision time protocol parameters

Example:
PTPSET, EN=0, OFFSET=0, CL=1609193402
OK
PTPSET, EN=2, IP="129.240.3.3"
OK

PTPGET

Get precision time protocol parameters

Example:

PTPGET, EN, OFFSET, CL

9.37 Get hardware specifications

Command: GETHW

Command type: INFO

Mode: COMMAND, CONFIRMATION, MEASUREMENT, RETRIEVAL

Returns Firmware versions and Board revisions.

Argument	Description
FW	Running DSP FW version
FWMINOR	Running DSP FW version (minor part)
FPGA	Running FPGA FW version
BOOT	DSP bootloader FW Version
DIGITAL	Board revision. Example: C-0
INTERFACE	Board revision. Example: C-0
ANALOG	Board revision. Example: C-0
ANALOG2	Board 2 revision. Example: C-0
SENSOR	Board revision. Example: C-0

Example:

GETHW, FW, MINOR

9.38 Add license

Command: ADDLICENSE

Command type: PRODUCTION

Access: User

Mode: COMMAND

Reads a license key and checks it against the instrument serial number before adding it to the license key flash.

Argument	Description
KEY	The license key to add

Example:

ADDLICENSE, KEY="9H3F5PE47HUUB"

OK

9.39 Delete license

Command: DELETELICENSE

Command type: PRODUCTION

Access: User

Mode: COMMAND

Deletes a license key from the license key flash.

Argument	Description
KEY	The license key to delete

Example:

```
DELETELICENSE, KEY="9H3F5PE47HUUB"
```

OK

9.40 Lists license keys

Command: LISTLICENSE

Command type: INFO

Access: User

Mode: COMMAND

Lists all license keys contained in the license key flash along with a description of the functionality enabled by the key and the variant number of the license.

Argument	Description
KEY	License key
DESC	Information about license type
TYPE	License id

Example:

```
LISTLICENSE
```

```
LISTLICENSE, "4X218TRTRPNUB", "High Resolution", 4
```

```
LISTLICENSE, "JKHFFNH3RPNUB", "Wave Mode", 6
```

```
LISTLICENSE, "WF3CJR6PRPNUB", "Current Profiler", 1
```

OK

```
$PNOR, LISTLICENSE*76
```

```
$PNOR, LISTLICENSE, KEY="4X218TRTRPNUB", DESC="High  
Resolution", TYPE=4*73
```

```
$PNOR, LISTLICENSE, KEY="JKHFFNH3RPNUB", DESC="Wave Mode", TYPE=6*00
```

```
$PNOR,LISTLICENSE,KEY="WF3CJR6PRPNUB",DESC="Current
Profiler",TYPE=1*1C
$PNOR,OK*2B
```

10 Output Data Formats

This section gives an overview of the different output data formats. This chapter is divided into four parts; Bottom Track data formats, Water Track data formats, Current Profile data formats, and Altimeter data formats. Each of these chapters are divided into two sections, Binary output formats and ASCII output formats.

PDx data outputs

Nortek has limited sales support for PDx legacy formats such as PD0, PD 4, PD 5 and PD6. Nortek data processing software does not work with PDx formats which results in Nortek being unable to assist with any data or debugging review. We do not support more recent PDx data formats and recommend that all customers use Nortek DF formats to get the maximum performance from their instruments.

DF vs PD data format comparison



	DF21	DF22	DF150 (PD0)	DF154 (PD4)	DF155 (PD5)	DF156 (PD6)
System info	✓	✓		✓	✓	
Speed of sound	✓	✓	✓			✓
Temperature	✓	✓	✓	✓	✓	✓
Pressure (depth)	✓	✓	✓		✓	✓
Water velocity		✓	✓	✓	✓	✓
Bottom velocity (X,Y,Z)	✓		✓	✓	✓	✓
Distance to bottom	✓		✓	✓	✓	✓
Distance to measurement cell		✓				
Beam velocity	✓	✓				
Beam distance	✓	✓				
Time of trigger to center of echo (time of validity)	✓	✓				
Velocity uncertainty estimate (Figure of Merit)	✓	✓				

10.1 Bottom Track Data Formats

The data format of the Bottom Track mode is controlled by the SET/GETBT command. The DF parameter of this command sets the data format

Binary:

Data format (DF)	Description
21	Nortek DVL Bottom Track data format
150	RDI PD0 – RDI documentation
154	RDI PD4 – RDI documentation
155	RDI PD5 - RDI documentation

Table 2: Available Binary Data formats for Bottom Track measurements.

ASCII:

Data format (DF)	Description
156	RDI PD6 – RDI documentation
163	RDI PD13 – RDI documentation
350	NMEA \$PNORBT1 including tags
351	NMEA \$PNORBT0 (same as DF350 but no tags)
354	NMEA \$PNORBT3 including tags
355	NMEA \$PNORBT4 (same as DF354 but no tags)
356	NMEA \$PNORBT6 including tags
357	NMEA \$PNORBT7 (same as DF356 but no tags)
358	NMEA \$PNORBT8 (sensors) including tags
359	NMEA \$PNORBT9 (Sensors) (same as DF358 but no tags)

Table 2: Available ASCII Data formats for Bottom Track measurements.

10.2 Water Track Data Formats

The data format of the Water Track mode is controlled by the SET/GETBT command. The WTDF parameter of this command sets the data format

Binary:

Data format (DF)	Description
22	Nortek DVL Water Track data format
150	RDI PD0 – RDI documentation
154	RDI PD4 – RDI documentation
155	RDI PD5 - RDI documentation

Table 3: Available Binary Data formats for Water Track measurements.

ASCII:

Data format (DF)	Description
156	RDI PD 6 – RDI documentation
163	RDI PD 13 – RDI documentation
404	NMEA \$PNORWT3 including tags
405	NMEA \$PNORWT4 (same as DF404 but no tags)
406	NMEA \$PNORWT6 including tags
407	NMEA \$PNORWT7 (same as DF406 but no tags)
408	NMEA \$PNORWT8 (sensors) including tags
409	NMEA \$PNORWT9 (sensors) (same as DF408 but no tags)

Table 3: Available ASCII Data formats for Water Track measurements.

10.3 Current Profile Data Formats

The data format of the Current Profiling mode is controlled by the SET/GETCURPROF command. The DF parameter of this command sets the data format.

Binary:

Data format (DF)	Description
3	Nortek Current Profile data format.
150	RDI PD0 – RDI Documentation.

Table 4: Available Binary Data formats for Current Profile measurements.

ASCII:

Data format (DF)	Description
100	NMEA Nortek Prolog format (see Prolog documentation)
101	NMEA \$PNOR1, \$PNORS1, \$PNORC1, No tags
102	NMEA \$PNOR2, \$PNORS2, \$PNORC2, Including tags
103	NMEA \$PNORH3, \$PNORS3, \$PNORC3, Including tags
104	NMEA \$PNORH4, \$PNORS4, \$PNORC4, No tags

Table 4: Available ASCII Data formats for Current Profile measurements.

10.4 Altimeter Data Formats

The data format of the Altimeter is controlled by the SET/GETALTI command. The DF parameter of this command sets the data format.

Binary:

Data format (DF)	Description
30	Nortek Altimeter data format

Table 5: Available Binary Data formats for Altimeter measurements.

ASCII:

Data format (DF)	Description
200	NMEA \$PNORA
201	NMEA \$PNORA including tags
202	NMEA \$SDDBT

Table 5: Available ASCII Data formats for Altimeter measurements.

11 Binary data formats

This chapter describes the Nortek DVL binary data formats for sensor output. Note that the binary data formats all use a common header that specifies how the rest of the data block should be interpreted. A data block is the data from and including one header to the next. Binary data are always sent as Little Endian.

About these chapters

Each data format is described in the following chapters. To avoid duplicating rows in the following tables, we have documented header and common data separately. This way, the chapter on one data format will only contain the fields unique for this data format. Take DF3 velocity data as an example:

In short: The data format is the sum of header data, two parts that are shared with other types of data blocks, and the part that is unique for velocity. Se figure below.

A little longer: The header is the same for all data blocks. It is compact and quick to parse, and it contains information about the rest of the data (e.g. data type and size). This is documented separately as `_HeaderData`. We use the leading underscore to emphasize that this is a not a complete data format, but it is a part used by two or more data formats.

The same goes for other common data such as data format version number, offset to data and timestamp etc. This is documented separately in `_CommonData`. Note that for DF3 velocity data there is also another part that is shared.

Last, there are the unique fields such as beam configuration, velocity data, amplitude data etc. that is given in the table in DF3 velocity data.

The table below is an illustration on how common data fields (gray for header and blue for other common's) relate to the sensor specific data fields (green).

<code>_HeaderData</code>			
<code>_CommonData</code>		<code>DF21BottomTrack/ DF22WaterTrack</code>	<code>DF30 AltimeterData</code>
<code>_DF3 CurrentProfileData</code>			
<code>DF3 VelocityData</code>	<code>DF3 SpectrumData</code>		

Figure: Showing how common data fields (gray for header and blue for other common's) relate to the sensor specific data fields (green). Note that we use a leading underscore (`_`) to emphasize that this is not a sensor data format but is common and used by two or more data formats.

About the tables

Tables have the columns 'Field', 'Position/Size' and 'Description'. Position and size may need an explanation:

Position has the location of a field in the header or in the data that follows the header. E.g., the 'data series id' has position 2 (Note that we are counting from 0) in the header. Some positions are not fixed, but dependent on which fields are before it. In these cases, 'offset of data' (position 1 of the data - see `_CommonData`) can then be used to give the position of the following fields. In these cases, the position in the table will not be given as a number but as a variable name such as `OFFSET`. Variable descriptions are listed below the tables where they are used.

Size is the data type of field. In case of 'data series id' it is an unsigned integer of 8 bits (uint8). Note that not all fields have a specific data type but is an object using a required number of bits. E.g., the status bit masks often use 32 bits to provide 'ok'/'not ok' on several parts of the data. These object sizes and their descriptions are listed below the table where they are used.

11.1 `_HeaderData`

The header definition for binary data formats. Note that the header may be verified without reading the rest of the data block since it has its own checksum.

Field	Position Size	Description
Sync byte	0 uint8	Always 0xA5.
Header size	1 uint8	Number of bytes in the headers. Normally it is 10 bytes, but in a few cases it may be 12 bytes to hold data size of 32 bytes.
Data series id	2 uint8	Defines the type of the following Data Record. 0x16 - Average Data Record. 0x21 - Altimeter Data Record. 0x1B - DVL Bottom Track Record. 0x1D - DVL Water Track Record. 0xA0 - String Data Record, eg. GPS NMEA data, comment from the FWRITE command.
Family id	3 uint8	Defines the Instrument Family. 0x10 is the Signature Family. 0x16 is the DVL family. 0x30 is the Aquadopp Generation 2 family.

		0x40 is the Awac Generation 2 family.
Data size	4 uint16/uint32	Number of bytes in the following Data Record. If header size is 10, the data size is represented with a uint16. For large datasets, header may have 12 bytes giving room for a uint32 to represent data size.
Data checksum	6/8 uint16	Checksum of the following Data Record.
Header checksum	8/10 uint16	Checksum of all fields of the Header except the Header Checksum itself.

11.2 _CommonData

Used By: _DF3 CurrentProfileData

Common data definitions for parsing Nortek data formats.

Field	Position Size	Description
Version	0 uint8	Version number of the Data Record Definition.
Offset of data	1 uint8	Number of bytes from start of the record to start of the actual data. Unit: [# bytes]
Serial number	4 uint32	Instrument serial number from factory.
Year	8 uint8	Number of years since 1900.
Month	9 uint8	Month number counting from 0 which is January.
Day	10 uint8	Day of the month
Hour	11 uint8	24 hour of the day
Minutes	12 uint8	Minutes.
Seconds	13 uint8	Seconds.
Hundred micro seconds	14 uint16	Hundred micro seconds from last whole second. Unit: [100 μs]
Speed of sound	16 uint16	Speed of sound used by the instrument. Raw data given as 0.1 m/s Unit: [m/s]

Temperature	18 int16	Reading from the temperature sensor. Raw data given as 0.01 °C Unit: [°C]
Pressure	20 uint32	Raw data given as 0.001 dBar Unit: [dBar]
Heading	24 uint16	Raw data given as 0.01 degrees Unit: [deg]
Pitch	26 int16	Raw data given as 0.01 degrees Unit: [deg]
Roll	28 int16	Raw data given as 0.01 degrees Unit: [deg]
Cell size	32 uint16	Size of each cell (resolution) on the beam. Raw data given as mm Unit: [m]
Nominal correlation	36 uint8	The nominal correlation for the configured combination of cell size and velocity range Unit: [%]
Battery voltage	38 uint16	Raw value given in 0.1 Volt Unit: [V]
Magnetometer.X	40 int16	X axis flux raw value in last measurement interval
Magnetometer.Y	42 int16	Y axis flux raw value in last measurement interval
Magnetometer.Z	44 int16	Z axis flux raw value in last measurement interval
Accelerometer.X	46 int16	Raw accelerometer X axis value in last measurement interval Raw value divided by 16384 will give vector [x,y,z] of length 1 Note: The unit of the instrument is gravity [g]. Conversion of Accelerometer unit less raw measurements to m/s ² : divide measurement by 16384, then multiply by calibrated gravity in Oslo, 9.819 m/s ² .
Accelerometer.Y	48 int16	Raw Y axis value in last measurement interval Raw value divided by 16384 will give vector [x,y,z] of length 1
Accelerometer.Z	50 int16	Raw Z axis value in last measurement interval. Raw value divided by 16384 will give vector [x,y,z] of length 1

Data set description	54/56 uint16	Data set description. 0-3 Physical beam used for 1st data set. 4-7 Physical beam used for 2nd data set. 8-11 Physical beam used for 3th data set. 12-16 Physical beam used for 4th data set.
Transmitted energy	56/58 uint16	Transmitted energy.
Velocity scaling	58/60 int8	Velocity scaling used to scale velocity data.
Power level	59/61 int8	Configured power level Unit: [dB]
Magnetometer temperature	60/62 int16	Magnetometer temperature reading. Uncalibrated Raw data in 1/1000 °C Unit: [°C]
Real time clock temperature	62/64 int16	Real Time Clock temperature reading Unit: [°C]
Error status	64/66 2 * 8 bits	Error bit mask Object reference given in table below
Ensemble counter	72/74 uint32	Counts the number of ensembles in both averaged and burst data

Position and size variables:

Name	Description
54/56	The status field is at 54 or 56 depending on whether the ambiguity velocity (in DF3 CurrentProfileData) is 16bit or 32bit long.
56/58	The status field is at 56 or 58 depending on whether the ambiguity velocity (in DF3 CurrentProfileData) is 16bit or 32bit long.
58/60	The status field is at 56 or 58 depending on whether the ambiguity velocity (in DF3 CurrentProfileData) is 16bit or 32bit long.
59/61	The status field is at 59 or 61 depending on whether the ambiguity velocity (in DF3 CurrentProfileData) is 16bit or 32bit long.
60/62	The status field is at 60 or 62 depending on whether the ambiguity velocity (in DF3 CurrentProfileData) is 16bit or 32bit long.
62/64	The status field is at 62 or 64 depending on whether the ambiguity velocity (in DF3 CurrentProfileData) is 16bit or 32bit long.
64/66	The status field is at 64 or 66 depending on whether the ambiguity velocity (in DF3 CurrentProfileData) is 16bit or 32bit long.
72/74	The status field is at 72 or 74 depending on whether the ambiguity velocity (in DF3 CurrentProfileData) is 16bit or 32bit long.

Object reference: Error status

Error bit mask

Field	Position Size	Description
Data retrieval FIFO error	0 bit	Data retrieval FIFO error
Data retrieval overflow	1 bit	Data retrieval overflow
Data retrieval underrun	2 bit	Data retrieval Underrun
Data retrieval samples missing	3 bit	Data retrieval samples missing
Measurement not finished	4 bit	The Measurement and data storage/transmit didn't finish before next measurement started.
Sensor read failure	5 bit	Sensor read failure
Tag error beam 1 (In-phase)	8 bit	Tag error beam 1 (In-phase)
Tag error beam 1 (Quadrature-phase)	9 bit	Tag error beam 1 (Quadrature-phase)
Tag error beam 2 (In-phase)	10 bit	Tag error beam 2 (In-phase)
Tag error beam 2 (Quadrature-phase)	11 bit	Tag error beam 2 (Quadrature-phase)
Tag error beam 3 (In-phase)	12 bit	Tag error beam 3 (In-phase)
Tag error beam 3 (Quadrature-phase)	13 bit	Tag error beam 3 (Quadrature-phase)
Tag error beam 4 (In-Phase)	14 bit	Tag error beam 4 (In-phase)
Tag error beam 4 (Quadrature-phase)	15 bit	Tag Error Beam 4 (Quadrature-phase)

11.3 StringData

ID: 0xa0

String Data Record, eg. GPS NMEA data, comment from the FWRITE command.

Field	Position Size	Description
String	0 Size of record bytes	String data record.

11.4 _DF3 CurrentProfileData

Extends: _CommonData

Used By: DF3 VelocityData, DF3 SpectrumData

Common data definitions for Nortek data format 3 (DF3).

Field	Position Size	Description
Configuration bit mask	2 2 * 8 bits	Record Configuration Bit Mask Object reference given in table below
Blanking	34 uint16	Distance from instrument to first data point on the beam. Raw data given as cm or mm depending on status.blankingDistanceScalingInCm Unit: [m]
Temperature PressureSensor	37 uint8	Temperature of pressure sensor: $T=(Val/5)-4.0$ Raw value given as 0.2 °C Unit: [°C]
Ambiguity Velocity	52 uint16	Ambiguity velocity, corrected for sound velocity, scaled according to Velocity scaling. $10^{(Velocity\ scaling)}\ m/s$ Unit: [m/s]
Extended status	66 2 * 8 bits	Extended status bit mask Object reference given in table below
Status	68 4 * 8 bits	Status bit mask. Note that bits 0, 2, 3, 4 are unused. Object reference given in table below

Object reference: Configuration bit mask

Record Configuration Bit Mask

Field	Position Size	Description
-------	---------------	-------------

Has pressure sensor	0 bit	Pressure sensor value valid
Has temperature sensor	1 bit	Temperature sensor value valid
Has compass sensor	2 bit	Compass sensor value valid
Has tilt sensor	3 bit	Tilt sensor value valid
Has external sensor	4 bit	External sensor value valid
Has velocity data	5 bit	Velocity data included
Has amplitude data	6 bit	Amplitude data included
Has correlation data	7 bit	Correlation data included
Has altimeter data	8 bit	Altimeter data included
Has altimeter raw data	9 bit	Altimeter raw data included
Has AST data	10 bit	AST data included
Has echosounder data	11 bit	Echosounder data included
Has AHRS data	12 bit	AHRS data included
Has percentage good data	13 bit	Percentage data included
Has standard deviation data	14 bit	Standard deviation data included
Has spectrum data	15 bit	Amplitude spectrum data included.

Object reference: Extended status

Extended status bit mask

Field	Position Size	Description
-------	---------------	-------------

Processor idles < 3%	0 bit	Indicates that the processor idles less than 3 percent
Processor idles < 6%	1 bit	Indicates that the processor idles less than 6 percent
Processor idles < 12%	2 bit	Indicates that the processor idles less than 12 percent
External sound velocity probe	3 bit	Sound velocity probe velocity received
External heading, pitch, roll, and position	4 bit	External heading, pitch, roll and position received from NMEA NTKNAV
External heading	5 bit	External heading received from NMEA input
External pitch and roll	6 bit	External pitch and roll received from NMEA input
Ethernet powered system	7 bit	Indicates if the system is powered via Ethernet
File system flush	13 bit	File system flush in progress
Internal processing	14 bit	Internal processing in progress (e.g. wave processing)
Extended status should be interpreted	15 bit	If this bit is set the rest of the word/ extended status should be interpreted

Object reference: Status

Status bit mask. Note that bits 0, 2, 3, 4 are unused.

Field	Position Size	Description
Blanking distance scaling in cm	1 bit	Bit 1: Scaling of blanking distance 0: mm scaling 1: given in cm
Echosounder frequency bin	5-9 5 bit	Used only on the Signature100 which supports up to 5 packages pr frequency index. Processing is then done on the different frequency bands.
Boost running	10 bit	Boost running
Telemetry data	11 bit	Telemetry data

Echosounder index	12-15 4 bits	Echosounder frequency index. Valid numbers are 0, 1 and 2 (or 0000, 0001 and 0010) referring to frequencies 1, 2 or 3 as used in SET-/GETECHO.
Active configuration	16 bit	Bit 16: Active configuration 0: Settings for PLAN,BURST,AVG 1: Settings for PLAN1,BURST1,AVG1
Previous measurement skipped due to low voltage	17 bit	Bit 17: Last measurement low voltage skip 0: normal operation 1: last measurement skipped due to low input voltage
Previous wakeup state	18-21 4 bits	0 - Bad power 1 - Power on 2 - Break 3 - RTC 4 - Watchdog 5 - Low voltage 6 - Filesystem error
Auto orientation	22-24 3 bits	0: "Fixed" Fixed orientation 1: "Auto" Auto Up Down 3: "AHRS3D" AHRS3D
Orientation	25-27 3 bits	0: "XUP" Instrument x-axis defined up, heading reference axis is Z positive 1: "XDOWN" Instrument x-axis defined down, heading reference axis is Z positive 2: "YUP" Instrument y-axis defined up, heading reference axis is Z positive 3: "YDOWN" Instrument y-axis defined down, heading reference axis is Z positive 4: "ZUP" Instrument z-axis defined up, heading reference axis is X positive 5: "ZDOWN" Instrument z-axis defined down, heading reference axis is X positive 7: "AHRS" AHRS reports orientation any way it points. Example: Z down -> Roll = 180 deg.
Wake up state	28-31 4 bits	0 - Bad power 1 - Power on 2 - Break 3 - RTC 4 - Watchdog 5 - Low voltage 6 - Filesystem error

11.5 DF3 VelocityData

Extends: _DF3 CurrentProfileData

ID: 0x15, 0x16, 0x18, 0x1e, 0x1a, 0x1f

Data definitions for parsing Nortek velocity data format 3.

Field	Position Size	Description
Beams, coordinates and cells	30 2 bytes	Number of beams, coordinate system and number of cells. Object reference given in table below
STM data.Scattering	OFFSET float	Scattering measured by STM sensor
STM data.HighRange	OFFSET + 4 float	High range measured by STM sensor
STM data.reserved	OFFSET + 8 float * 4	4 reserved floats
Velocity data	VEL_START int16 * VEL_NB * VEL_NC	This field exists if the Velocity data included bit of the Config byte is set. 10 ^(Velocity Scaling) Unit: [m/s]
Amplitude data	AMP_POS uint8 * AMP_NB * AMP_NC	This field exists if the amplitude data included bit of the Config byte is set 0.5 dB/count Unit: [dB]
Correlation data	CORR_POS uint8 * CORR_NB * CORR_NC	This field exists if the Correlation data included bit of the Config byte is set [0 – 100 %] Unit: [%]
Altimeter data.Altimeter distance	ALTI_POS float	Distance to surface from Leading Edge algorithm Unit: [m]
Altimeter data.Altimeter quality	ALTI_POS + 4 uint16	Result of LE algorithm. When quality is deemed too low according to instrument specific limits both the distance and quality are set to 0.
Altimeter data.Altimeter status	ALTI_POS + 6 2 * 8 bits	Altimeter status bit mask
AST data.AST distance	AST_POS float	Distance to surface from Max Peak/AST algorithm Unit: [m]
AST data.AST quality	AST_POS + 4 uint16	Amplitude at which surface is detected with the Max Peak/AST algorithm.

		Raw data in steps of 0.01 dB, i.e. quality of 8000 = 80 dB Unit: [dB]
AST data.AST offset	AST_POS + 6 int16	Offset in step of measurement to velocity measurement Raw data given in 100 μ s Unit: [s]
AST data.AST pressure	AST_POS + 8 float	Pressure value measured during the AST/altimeter ping Unit: [dbar]
Altimeter raw data.Num RawSamples	ALTIRAW_START + 8 uint32	Altimeter Raw Data – Number of Samples
Altimeter raw data.Samples distance	ALTIRAW_START + 12 uint16	Distance between samples Raw data given in 0.1mm Unit: [m]
Altimeter raw data.Data samples	ALTIRAW_START + 14 int16 * NRS	Altimeter Raw Data – Samples Raw data given as 16 bits Signed fract
AHRS data.Rotation matrix	AHRS_START float * 3 * 3	AHRS Rotation Matrix [3x3]
AHRS data.Quaternion W	AHRS_START + 36 float	W quaternion
AHRS data.Quaternion X	AHRS_START + 40 float	X quaternion
AHRS data.Quaternion Y	AHRS_START + 44 float	Y quaternion
AHRS data.Quaternion Z	AHRS_START + 48 float	Z quaternion
AHRS data.Gyro X	AHRS_START + 52 float	Gyro in X direction in degrees pr second Unit: [dps]
AHRS data.Gyro Y	AHRS_START + 56 float	Gyro in Y direction in degrees pr second Unit: [dps]
AHRS data.Gyro Z	AHRS_START + 60 float	Gyro in Z direction in degrees pr second Unit: [dps]
Percentage good data	PGD_START uint8 * PGD_LEN	Percent Good Estimate per cell This field exists if the Percentage Good data is included. For the Signature instruments, this will only be relevant for the _avgd.ad2cp file. Unit: [%]
Standard deviation data.Pitch	SD_START int16	Standard deviation on pitch data Raw data in 0.01 degrees

		Unit: [deg]
Standard deviation data.Roll	SD_START + 2 int16	Standard deviation on roll data Raw data in 0.01 degrees Unit: [deg]
Standard deviation data.Heading	SD_START + 4 int16	Standard deviation on heading data Raw data in 0.01 degrees Unit: [deg]
Standard deviation data.Pressure	SD_START + 6 int16	Standard deviation on pressure data Raw data in 0.001 Bar Unit: [bar]

Position and size variables:

Name	Description
STM_LEN	STM length.
OFFSET	Offset of data given at position 1 in this dataset. Number of bytes from start of record to start of data.
VEL_NB	Primary dimension of velocity data is number of beams. Length 0 if correlation data in configuration bit map is false.
VEL_NC	Second dimension of velocity data is number of cells pr beam. Length 0 if correlation data in configuration bit map is false.
VEL_START	Starting byte position of velocity data, which comes after the STM data section.
AMP_NB	Primary dimension of amplitude data is number of beams. Length 0 if correlation data in configuration bit map is false.
AMP_NC	Second dimension of amplitude data is number of cells pr beam. Length 0 if correlation data in configuration bit map is false.
AMP_POS	Correlation data starts after the amplitude data.
CORR_NB	Primary dimension of correlation data is number of beams. Length 0 if correlation data in configuration bit map is false.
CORR_NC	Second dimension of correlation data is number of cells pr beam. Length 0 if correlation data in configuration bit map is false.
CORR_POS	Correlation data starts after the amplitude data.
ALTI_POS	Altimeter data starts after the correlation data.
AST_POS	AST data starts after the altimeter data.
NRS	Number of raw samples given as first element of this object.
ALTIRAW_START	Altimeter raw data starts after the AST data.
AHRS_START	AHRS data follows the altimeter raw data.
PGD_START	Percent good data follows the AHRS data.

SD_START	The standard deviation data follows percent good data.
----------	--

Object reference: Beams, coordinates and cells

Number of beams, coordinate system and number of cells.

Field	Position Size	Description
Number of beams	15-12 2 bits	Number of Beams (NB) Active beams represented as a 4 char string of 1s and 0s.
Coordinate system	11-10 2 bits	Coordinate system 00 = ENU 01 = XYZ 10 = BEAM 11 = not used
Number of cells	9-0 10 bits	Number of Cells (NC).

11.6 DF3 SpectrumData

Extends: _DF3 CurrentProfileData

ID: 0x20

Data definitions for parsing DF3 amplitude spectrum data.

Field	Position Size	Description
Beams and bins	30 2 bytes	Number of bins in the frequency spectrum. Object reference given in table below
Spectrum data.Start frequency	OFFSET float	Start frequency value Unit: [Hz]
Spectrum data.Step frequency	OFFSET + 4 float	Step frequency value Unit: [Hz]
Spectrum data.Frequency data	OFFSET + 64 int16 * BEAMS * BINS	Frequency spectrum amplitude data. There is room for 16 floating points for a spectrum header before the frequency data. Unit: [dB]

Position and size variables:

Name	Description
------	-------------

BEAMS	Matrix first dimension is number of beams. Eg: [[f_start, .., f_{start+step*(bins-1)}]_{beam1} [f_start, .., f_{start+step*(bins-1)}]_{beam2} .. [f_start, .., f_{start+step*(bins-1)}]_{beams}}
BINS	Per beam, frequencies are given as an array of length as number of bins. First element is the start frequency and frequencies increment by step frequency per element of the array. Eg: [[f_start, f_{start+step}, f_{start+step*2}, .., f_{start+step*(bins-1)}]_{beam1}, .., ..]
16+BEAMSxBINSx2	If configuration.hasSpectrumData is false, spectrum data is length 0. RAW: !this.configuration.hasSpectrumData ? 0 : this.beamsAndBins.numberOfBeams*this.beamsAndBins.numberOfBins*2 + 16*4
OFFSET	Number of bytes from start of record to start of data.

Object reference: Beams and bins

Number of bins in the frequency spectrum.

Field	Position Size	Description
Number of beams	15-13 3 bits	Number of active beams.
Number of bins	12-0 13 bits	Number of bins.

11.7 DF21 BottomTrack / DF22 WaterTrack

ID: 0x1b, 0x1d

Data definitions for parsing bottom track (DF21) and water track (DF22).

Field	Position Size	Description
Version	0 uint8	Version number of the Data Record Definition. Should be 3
Offset OfData	1 uint8	Number of bytes from start of the record to start of the actual data. Unit: [# bytes]
Serial Number	2 uint32	Instrument serial number from factory.
Year	6 uint8	Number of years since 1900.

Month	7 uint8	Month number counting from 0 which is January.
Day	8 uint8	Day of the month
Hour	9 uint8	24 hour of the day
Minutes	10 uint8	Minutes.
Seconds	11 uint8	Seconds.
Hundred micro seconds	12 uint16	Hundred micro seconds from last whole second. Unit: [100 μ s]
Num Beams	14 uint16	Number of beams
Error status	16 4 * 8 bits	Error bit mask Object reference given in table below
Status	20 4 * 8 bits	Status bit mask Object reference given in table below
Sound Speed	24 float	Sound Speed Unit: [m/s]
Temperature	28 float	Temperature Unit: [°C]
Pressure	32 float	Pressure Unit: [Bar]
Velocity beam 1	36 float	Velocity beam 1 invalid estimates set to -32.768 Unit: [m/s]
Velocity beam 2	40 float	Velocity beam 2 invalid estimates set to -32.768 Unit: [m/s]
Velocity beam 3	44 float	Velocity beam 3 invalid estimates set to -32.768 Unit: [m/s]
Velocity beam 4	48 float	Velocity beam 4 invalid estimates set to -32.768 Unit: [m/s]
Distance beam 1	52 float	Distance beam 1 For DF21: Vertical Distance For DF22: Distance along beam to start of water track cell invalid estimates set to 0.0

		Unit: [m]
Distance beam 2	56 float	Distance beam 2 For DF21: Vertical Distance For DF22: Distance along beam to start of water track cell invalid estimates set to 0.0 Unit: [m]
Distance beam 3	60 float	Distance beam 3 For DF21: Vertical Distance For DF22: Distance along beam to start of water track cell invalid estimates set to 0.0 Unit: [m]
Distance beam 4	64 float	Distance beam 4 For DF21: Vertical Distance For DF22: Distance along beam to start of water track cell invalid estimates set to 0.0 Unit: [m]
Uncertainty beam 1	68 float	Estimated velocity uncertainty reported as one standard deviation (Figure of merit - FOM) for beam 1. invalid estimates set to 10.0 Unit: [m/s]
Uncertainty beam 2	72 float	Estimated velocity uncertainty reported as one standard deviation (Figure of merit - FOM) for beam 2. invalid estimates set to 10.0 Unit: [m/s]
Uncertainty beam 3	76 float	Estimated velocity uncertainty reported as one standard deviation (Figure of merit - FOM) for beam 3. invalid estimates set to 10.0 Unit: [m/s]
Uncertainty beam 4	80 float	Estimated velocity uncertainty reported as one standard deviation (Figure of merit - FOM) for beam 4. invalid estimates set to 10.0 Unit: [m/s]
Dt1 beam 1	84 float	DT1 beam 1 Unit: [s]
Dt1 beam 2	88 float	DT1 beam 2 Unit: [s]

Dt1 beam 3	92 float	DT1 beam 3 Unit: [s]
Dt1 beam 4	96 float	DT1 beam 4 Unit: [s]
Dt2 beam 1	100 float	DT2 beam 1 Unit: [s]
Dt2 beam 2	104 float	DT2 beam 2 Unit: [s]
Dt2 beam 3	108 float	DT2 beam 3 Unit: [s]
Dt2 beam 4	112 float	DT2 beam 4 Unit: [s]
Time Velocity Estimate beam 1	116 float	Time Velocity Estimate beam 1 Duration of velocity estimate for each beam. For DF22 only: To calculate cell size, multiply by half the speed of sound (e.g. 750 m/s). Velocity estimates are always referenced to the middle of this cell. Unit: [s]
Time Velocity Estimate beam 2	120 float	Time Velocity Estimate beam 2 Duration of velocity estimate for each beam. For DF22 only: To calculate cell size, multiply by half the speed of sound (e.g. 750 m/s). Velocity estimates are always referenced to the middle of this cell. Unit: [s]
Time Velocity Estimate beam 3	124 float	Time Velocity Estimate beam 3 Duration of velocity estimate for each beam. For DF22 only: To calculate cell size, multiply by half the speed of sound (e.g. 750 m/s). Velocity estimates are always referenced to the middle of this cell. Unit: [s]
Time Velocity Estimate beam 4	128 float	Time Velocity Estimate beam 4 Duration of velocity estimate for each beam. For DF22 only: To calculate cell size, multiply by half the speed of sound (e.g. 750 m/s). Velocity estimates are always referenced to the middle of this cell. Unit: [s]
Velocity X	132 float	Velocity X Invalid estimates set to -32.768 Unit: [m/s]

Velocity Y	136 float	Velocity Y Invalid estimates set to -32.768 Unit: [m/s]
Velocity Z1	140 float	Velocity Z1 Invalid estimates set to -32.768 Unit: [m/s]
Velocity Z2	144 float	Velocity Z2 Invalid estimates set to -32.768 Unit: [m/s]
Uncertainty X	148 float	Estimated velocity uncertainty reported as one standard deviation (Figure of merit - FOM) in X dimension. Invalid estimates set to 10.0 Unit: [m/s]
Uncertainty Y	152 float	Estimated velocity uncertainty reported as one standard deviation (Figure of merit - FOM) in Y dimension. Invalid estimates set to 10.0 Unit: [m/s]
Uncertainty Z1	156 float	Estimated velocity uncertainty reported as one standard deviation (Figure of merit - FOM) in Z1 dimension. Invalid estimates set to 10.0 Unit: [m/s]
Uncertainty Z2	160 float	Estimated velocity uncertainty reported as one standard deviation (Figure of merit - FOM) in Z2 dimension. Invalid estimates set to 10.0 Unit: [m/s]
Dt1 X	164 float	DT1 X See Timing Information section for more details Unit: [s]
Dt1 Y	168 float	DT1 Y See Timing Information section for more details Unit: [s]
Dt1 Z1	172 float	DT1 Z1 See Timing Information section for more details Unit: [s]
Dt1 Z2	176 float	DT1 Z2 See Timing Information section for more details Unit: [s]
Dt2 X	180 float	DT2 X See Timing Information section for more details

		Unit: [s]
Dt2 Y	184 float	DT2 Y See Timing Information section for more details Unit: [s]
Dt2 Z1	188 float	DT2 Z1 See Timing Information section for more details Unit: [s]
Dt2 Z2	192 float	DT2 Z2 See Timing Information section for more details Unit: [s]
Time Velocity Estimate beam X	196 float	Time Velocity Estimate beam X Duration of velocity estimate for each beam. Unit: [s]
Time Velocity Estimate beam Y	200 float	Time Velocity Estimate beam Y Duration of velocity estimate for each beam. Unit: [s]
Time Velocity Estimate beam Z1	204 float	Time Velocity Estimate beam Z1 Duration of velocity estimate for each beam. Unit: [s]
Time Velocity Estimate beam Z2	208 float	Time Velocity Estimate beam Z2 Duration of velocity estimate for each beam. Unit: [s]

Object reference: Error status

Error bit mask

Field	Position Size	Description
Data retrieval FIFO error	0 bit	Data retrieval FIFO error
Data retrieval overflow	1 bit	Data retrieval overflow
Data retrieval underrun	2 bit	Data retrieval Underrun
Data retrieval samples missing	3 bit	Data retrieval samples missing
Measurement not finished	4 bit	The Measurement and data storage/transmit didn't finish before next measurement started.
Sensor read failure	5 bit	Sensor read failure

Tag error beam 1 (In-phase)	8 bit	Tag error beam 1 (In-phase)
Tag error beam 1 (Quadrature-phase)	9 bit	Tag error beam 1 (Quadrature-phase)
Tag error beam 2 (In-phase)	10 bit	Tag error beam 2 (In-phase)
Tag error beam 2 (Quadrature-phase)	11 bit	Tag error beam 2 (Quadrature-phase)
Tag error beam 3 (In-phase)	12 bit	Tag error beam 3 (In-phase)
Tag error beam 3 (Quadrature-phase)	13 bit	Tag error beam 3 (Quadrature-phase)
Tag error beam 4 (In-Phase)	14 bit	Tag error beam 4 (In-phase)
Tag error beam 4 (Quadrature-phase)	15 bit	Tag Error Beam 4 (Quadrature-phase)

Object reference: Status

Status bit mask

Field	Position Size	Description
Beam1 Velocity Valid	0 bit	Beam 1 Velocity Valid
Beam2 Velocity Valid	1 bit	Beam 2 Velocity Valid
Beam3 Velocity Valid	2 bit	Beam 3 Velocity Valid
Beam4 Velocity Valid	3 bit	Beam 4 Velocity Valid
Beam1 Distance Valid	4 bit	Beam 1 Distance Valid
Beam2 Distance Valid	5 bit	Beam 2 Distance Valid
Beam3 Distance Valid	6 bit	Beam 3 Distance Valid

Beam4 Distance Valid	7 bit	Beam 4 Distance Valid
Beam1 uncertainty Valid	8 bit	Beam 1 Figure of Merit Valid
Beam2 uncertainty Valid	9 bit	Beam 2 Figure of Merit Valid
Beam3 uncertainty Valid	10 bit	Beam 3 Figure of Merit Valid
Beam4 uncertainty Valid	11 bit	Beam 4 Figure of Merit Valid
Velocity X Valid	12 bit	X Velocity Valid
Velocity Y Valid	13 bit	Y Velocity Valid
Velocity Z1 Valid	14 bit	Z1 Velocity Valid
Velocity Z2 Valid	15 bit	Z2 Velocity Valid
Uncertainty X Valid	16 bit	X Figure of Merit Valid
Uncertainty Y Valid	17 bit	Y Figure of Merit Valid
Uncertainty Z1 Valid	18 bit	Z1 Figure of Merit Valid
Uncertainty Z2 Valid	19 bit	Z2 Figure of Merit Valid
Less 3% Capacity	20 bit	Less than 3% processing capacity left
Less 6% Capacity	21 bit	Less than 6% processing capacity left
Less 12% Capacity	22 bit	Less than 12% processing capacity left
Previous Wakeup State	28-31 4 bits	Previous wakeup State 0010 = break 0011 = RTC alarm 0000 = bad power 0001 = power applied

11.8 DF30 AltimeterData

ID: 0x21

Data format DF30 is used for DVL Altimeter measurements.

Note: This data format is only used with DVL models that are equipped with a dedicated altimeter beam.

Field	Position Size	Description
Version	0 uint8	Version number of this Data Record Definition. Should be 1.
Offset of data	1 uint8	Number of bytes from start of record to start of non-common data fields. Unit: [# bytes]
Serial Number	2 uint32	Instrument serial number from factory.
Year	6 uint8	Number of years since 1900.
Month	7 uint8	Month number counting from 0 which is January.
Day	8 uint8	Day of the month
Hour	9 uint8	24 hour of the day
Minutes	10 uint8	Minutes.
Seconds	11 uint8	Seconds.
Hundred micro seconds	12 uint16	Hundred micro seconds from last whole second. Unit: [100 μs]
Num Beams	14 uint16	Number of beams
Error status	16 4 * 8 bits	Error bit mask Object reference given in table below
Status	20 4 * 8 bits	Status bit mask Object reference given in table below
Sound Speed	24 float	Sound Speed Unit: [m/s]
Temperature	28 float	Temperature Unit: [°C]

Pressure	32 float	Pressure Unit: [Bar]
Altimeter Distance	36 float	Distance to bottom Unit: [m]
Altimeter quality	40 uint16	Quality parameter
Unused	42 34 bytes	34 bytes for future use

Object reference: Error status

Error bit mask

Field	Position Size	Description
Data retrieval FIFO error	0 bit	Data retrieval FIFO error
Data retrieval overflow	1 bit	Data retrieval overflow
Data retrieval underrun	2 bit	Data retrieval Underrun
Data retrieval samples missing	3 bit	Data retrieval samples missing
Measurement not finished	4 bit	The Measurement and data storage/transmit didn't finish before next measurement started.
Sensor read failure	5 bit	Sensor read failure
Tag error beam 1 (In-phase)	8 bit	Tag error beam 1 (In-phase)
Tag error beam 1 (Quadrature-phase)	9 bit	Tag error beam 1 (Quadrature-phase)
Tag error beam 2 (In-phase)	10 bit	Tag error beam 2 (In-phase)
Tag error beam 2 (Quadrature-phase)	11 bit	Tag error beam 2 (Quadrature-phase)
Tag error beam 3 (In-phase)	12 bit	Tag error beam 3 (In-phase)
Tag error beam 3 (Quadrature-	13 bit	Tag error beam 3 (Quadrature-phase)

phase)		
Tag error beam 4 (In-Phase)	14 bit	Tag error beam 4 (In-phase)
Tag error beam 4 (Quadrature-phase)	15 bit	Tag Error Beam 4 (Quadrature-phase)

Object reference: Status

Status bit mask

Field	Position Size	Description
Less 3% Capacity	20 bit	Less than 3% processing capacity left
Less 6% Capacity	21 bit	Less than 6% processing capacity left
Less 12% Capacity	22 bit	Less than 12% processing capacity left
Previous Wakeup State	28-31 4 bits	Previous wakeup State 0010 = break 0011 = RTC alarm 0000 = bad power 0001 = power applied

11.9 DF41 FastPressureData

ID: 0x41

The Fast pressure feature is a licensed mode for enabling rapid data output from the integrated pressure sensor. Note that higher data rates does not impact the resolution of the individual pressure estimates.

Field	Position Size	Description
Depth	0 float	Depth below the Surface. Unit: [m]

12 Timing Information

DT1 and DT2 are precision timing parameters used by Nortek DVLs to define the exact "time of validity" for acoustic measurements. These values are critical for high-performance subsea navigation, as they allow an Inertial Navigation System (INS) to perfectly synchronize DVL velocity data with its own high-speed estimates, effectively eliminating latency-related errors.

For DF21 data output

DT1 parameter is the time from the trigger to the center of the bottom echo that estimates the bottom track velocity. DT2 parameter is the time from the start of the output message to the center of the bottom echo. This will thus be a negative value.

For DF22 data output

DT1 parameter is the time from the trigger to the center of the water track cell that estimates the water track velocity. DT2 parameter is the time from the start of the output message to the center of the water track cell. This will thus be a negative value.

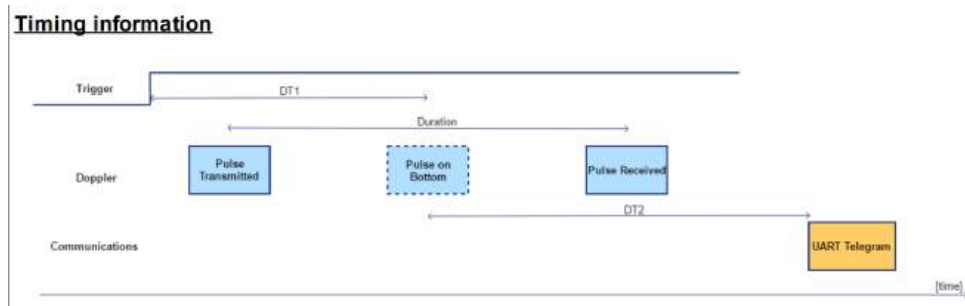

13 ASCII Data Formats

13.1 DVL Bottom Track ASCII formats

Invalid estimates of Velocity are set to set to -32.768.

Invalid estimates of Range are set to 0.0.

Invalid estimates of FOM are set to 10.0.

13.1.1 DF350/DF351 – NMEA \$PNORBT1/\$PNORBT0

The NMEA formats 350/351 have the following fields:

Field/TAG	Description	Data format	Example
BEAM	Beam number	n	BEAM=2
DATE	Date	DDMMYY	DATE=110916
TIME	Time	hhmmss.ssss	TIME=112034.0346
DT1	Time from the trigger to the centre of the bottom echo. [ms]	s.sss	DT1=55.717
DT2	Time from the start of the NMEA output message to the centre of the bottom echo. [ms]	s.sss	DT2=-157.912
BV	Beam Velocity	f.fffff	BV=0.15630
FM	Figure of Merit [m/s]	f.fffff	FM=0.00146

Field/TAG	Description	Data format	Example
DIST	Vertical Distance to bottom. [m]	f.ff	DIST=26.92
STAT	Status (see Table 7)	0xHHHHHHHH	STAT=0x000FFFFF

There is one text line output per beam so a four beam system will output four lines for each bottom track sample.

The DT1 parameter is the time from the trigger to the centre of the bottom echo that estimates the bottom track velocity. The DT2 parameter is the time from the start of the NMEA output message to the centre of the bottom echo. This will thus be a negative value.

Example (DF=350):

```
$PNORBT1, BEAM=1, DATE=110916, TIME=112034.0346, DT1=55.717, DT2=-157.789, BV=0.15633, FM=0.00066, DIST=26.92, STAT=0x000FFFFF*2A
$PNORBT1, BEAM=2, DATE=110916, TIME=112034.0346, DT1=55.717, DT2=-157.912, BV=0.15630, FM=0.00146, DIST=26.92, STAT=0x000FFFFF*25
$PNORBT1, BEAM=3, DATE=110916, TIME=112034.0346, DT1=55.717, DT2=-158.034, BV=-0.14928, FM=0.00165, DIST=26.92, STAT=0x000FFFFF*0D
$PNORBT1, BEAM=4, DATE=110916, TIME=112034.0346, DT1=54.892, DT2=-158.981, BV=-0.14925, FM=0.00359, DIST=26.92, STAT=0x000FFFFF*0E
```

13.1.2 DF354/DF355 – NMEA \$PNORBT3/\$PNORBT4

The NMEA formats 354/355 have the following fields:

Field/TAG	Description	Data format	Example
DT1	Time from the trigger to the centre of the bottom echo. [ms]	s.sss	DT1=1.234
DT2	Time from the start of the NMEA output message to the centre of the bottom echo. [ms]	s.sss	DT2=-1.234
SP	Speed over ground [m/s]	f.fff	SP=1.234
DIR	Direction [deg]	f.f	DIR=23.4
FOM	Figure of Merit [m/s]	f.ffff	FOM=12.34567
D	Vertical Distance to bottom. [m]	ff.f	D=12.3

DIR is the angle calculated by $\text{atan2}(\text{velY}, \text{velX})$ and is referenced to the X-axis.

DF354 outputs the tags. DF355 minimizes the number of character to be transmitted by discarding the tags in the outputted sentence.

Example (DF=354):

\$PNORBT3, DT1=1.234, DT2=-
1.234, SP=1.234, DIR=23.4, FOM=12.34567, D=12.3*65

Example (DF=355):

\$PNORBT4, 1.234, -1.234, 1.234, 23.4, 12.34567, 12.3*09

13.1.3 DF356/DF357 – NMEA \$PNORBT6/\$PNORBT7

The NMEA formats 356/357 have the following fields:

Field/TAG	Description	Data format	Example
TIME	Ping time [POSIX time]	s.ssss	TIME=1452244916.7508
DT1	Time from the trigger to the center of the bottom echo. [ms]	s.sss	DT1=1.234
DT2	Time from the start of the NMEA output message to the center of the bottom echo. [ms]	s.sss	DT2=-1.234
VX	Speed in X direction [m/s]	f.ffff	VX=0.1234
VY	Speed in Y direction [m/s]	f.ffff	VY=0.1234
VZ	Speed in Z direction [m/s]	f.ffff	VZ=0.1234
FOM	Figure of Merit [m/s]	f.ffff	FOM=12.34567
D1	Beam 1: Vertical Distance to bottom. [m]	f.ff	D1=23.45
D2	Beam 2: Vertical Distance to bottom. [m]	f.ff	D2=23.45
D3	Beam 3: Vertical Distance to bottom. [m]	f.ff	D3=23.45
D4	Beam 4: Vertical Distance to bottom. [m]	f.ff	D4=23.45

DF356 outputs the tags. DF357 minimizes the number of character to be transmitted by discarding the tags in the outputted sentence.

Example (DF=356):

```
$PNORBT6,TIME=1452244916.7508,DT1=1.234,DT2=-1.234,VX=0.1234,VY=0.1234,VZ=0.1234,FOM=12.34567,D1=23.45,D2=23.45,D3=23.45,D4=23.45*6A
```

Example (DF=357):

```
$PNORBT7,1452244916.7508,1.234,-1.234,0.1234,0.1234,0.1234,12.34,23.45,23.45,23.45,23.45*39
```

13.1.4 DF358/DF359 – NMEA \$PNORBT8/\$PNORBT9

The NMEA formats 358/359 have the following fields:

Field/TAG	Description	Data format	Example
TIME	Ping time [POSIX time]	s.ssss	TIME=1452244916.7508
DT1	Time from the trigger to the centre of the bottom echo. [ms]	s.sss	DT1=1.234
DT2	Time from the start of the NMEA output message to the centre of the bottom echo. [ms]	s.sss	DT2=-1.234
VX	Speed in X direction [m/s]	f.ffff	VX=0.1234
VY	Speed in Y direction [m/s]	f.ffff	VY=0.1234
VZ	Speed in Z direction [m/s]	f.ffff	VZ=0.1234
FOM	Figure of Merit [m/s]	f.ff	FOM=12.34
D1	Beam 1: Vertical Distance to bottom. [m]	f.ff	D1=23.45
D2	Beam 2: Vertical Distance to bottom. [m]	f.ff	D2=23.45
D3	Beam 3: Vertical Distance to bottom. [m]	f.ff	D3=23.45
D4	Beam 4: Vertical Distance to bottom. [m]	f.ff	D4=23.45
BATT	Battery Voltage [V]	f.f	BATT=23.4
SS	Speed of sound in Water [m/s]	f.f	SS=1567.8
PRESS	Pressure [dBar]	f.f	PRESS=1.2
TEMP	Water temperature [deg C]	f.f	TEMP=12.3
STAT	Status (see Table 7)	0xHHHHHHHH	STAT=0x000FFFFF

DF358 outputs the tags. DF359 minimizes the number of character to be transmitted by discarding the tags in the outputted sentence.

Example (DF=358):

```
$PNORBT8, TIME=1452244916.7508, DT1=1.234, DT2=-1.234, VX=0.1234, VY=0.1234, VZ=0.1234, FOM=12.34, D1=23.45, D2=23.45, D3=23.45, D4=23.45, BATT=23.4, SS=1567.8, PRESS=1.2, TEMP=12.3, STAT=0x000FFFFF*1E
```

Example (DF=359):

```
$PNORBT9,1452244916.7508,1.234,-  
1.234,0.1234,0.1234,0.1234,12.34,23.45,23.45,23.45,23.45,23.4,1567.  
8,1.2,12.3,0x000FFFFFF*1E
```

13.2 DVL Water Track ASCII formats

Invalid estimates of Velocity are set to set to -32.768.

Invalid estimates of Range are set to 0.0.

Invalid estimates of FOM are set to 10.0.

13.2.1 DF404/DF405 – NMEA \$PNORWT3/\$PNORWT4

The NMEA formats 404/405 have the following fields:

Field/TAG	Description	Data format	Example
DT1	Time from the trigger to the centre of the water track cell. [ms]	s.sss	DT1=1.234
DT2	Time from the start of the NMEA output message to the centre of the water track cell. [ms]	s.sss	DT2=-1.234
SP	Speed [m/s]	f.fff	SP=1.234
DIR	Direction [deg]	f.f	DIR=23.4
FOM	Figure of Merit [m/s]	f.ff	FOM=12.34
D	Vertical Distance to water track cell. [m]	ff.f	D=12.3

DIR is the angle calculated by $\text{atan2}(\text{velY}, \text{velX})$ and is referenced to the X-axis.

DF404 outputs the tags. DF405 minimizes the number of character to be transmitted by discarding the tags in the outputted sentence.

Example (DF=404):

```
$PNORWT3,DT1=1.2345,DT2=-1.2345,SP=1.234,DIR=23.4,FOM=12.34,D=12.3*44
```

Example (DF=405):

```
$PNORWT4,1.2345,-1.2345,1.234,23.4,12.34,12.3*1C
```

13.2.2 DF406/DF407 – NMEA \$PNORWT6/\$PNORWT7

The NMEA formats 406/407 have the following fields:

Field/TAG	Description	Data format	Example
TIME	Ping time [POSIX time]	s.ssss	TIME=1452244916.7508
DT1	Time from the trigger to the centre of water track cell. [ms]	s.sss	DT1=1.234
DT2	Time from the start of the NMEA output message to the centre of the water track cell. [ms]	s.sss	DT2=-1.234
VX	Speed in X direction [m/s]	f.ffff	VX=0.1234
VY	Speed in Y direction [m/s]	f.ffff	VY=0.1234
VZ	Speed in Z direction [m/s]	f.ffff	VZ=0.1234
FOM	Figure of Merit [m/s]	f.ff	FOM=12.34
D1	Beam 1: Vertical Distance to water track cell. [m]	f.ff	D1=23.45
D2	Beam 2: Vertical Distance to water track cell. [m]	f.ff	D2=23.45
D3	Beam 3: Vertical Distance to water track cell. [m]	f.ff	D3=23.45
D4	Beam 4: Vertical Distance to water track cell. [m]	f.ff	D4=23.45

DF406 outputs the tags. DF407 minimizes the number of character to be transmitted by discarding the tags in the outputted sentence.

Example (DF=406):

```
$PNORWT6,TIME=1452244916.7508,DT1=1.234,DT2=-1.234,VX=0.1234,VY=0.1234,VZ=0.1234,FOM=12.34,D1=23.45,D2=23.45,D3=23.45,D4=23.45*4B
```

Example (DF407):

```
$PNORWT7,1452244916.7508,1.234,-1.234,0.1234,0.1234,0.1234,12.34,23.45,23.45,23.45,23.45*2C
```

13.3 DVL Current Profile ASCII formats

13.3.1 DF408/DF409 – NMEA \$PNORWT8/\$PNORWT9

The NMEA formats 408/409 have the following fields:

Field/TAG	Description	Data format	Example
TIME	Ping time [POSIX GMT time]	s.ssss	TIME=1452244916.7508
DT1	Time from the trigger to the centre of the water track cell. [ms]	s.sss	DT1=1.234
DT2	Time from the start of the NMEA output message to the centre of the water track cell. [ms]	s.sss	DT2=-1.234
VX	Speed in X direction [m/s]	f.ffff	VX=0.1234
VY	Speed in Y direction [m/s]	f.ffff	VY=0.1234
VZ	Speed in Z direction [m/s]	f.ffff	VZ=0.1234
FOM	Figure of Merit [m/s]	f.ff	FOM=12.34
D1	Beam 1: Vertical Distance to water track cell. [m]	f.ff	D1=23.45
D2	Beam 2: Vertical Distance to water track cell. [m]	f.ff	D2=23.45
D3	Beam 3: Vertical Distance to water track cell. [m]	f.ff	D3=23.45
D4	Beam 4: Vertical Distance to water track cell. [m]	f.ff	D4=23.45
BATT	Battery Voltage [V]	f.f	BATT=23.4
SS	Speed of sound in Water [m/s]	f.f	SS=1567.8
PRESS	Pressure [dBar]	f.f	PRESS=1.2
TEMP	Water temperature [deg C]	f.f	TEMP=12.3
STAT	Status (see Table 7)	0xHHHHHHHH	STAT=0x000FFFFF

DF408 outputs the tags. DF409 minimizes the number of character to be transmitted by discarding the tags in the outputted sentence.

Example (DF=408):

```
$PNORWT8, TIME=1452244916.7508, DT1=1.234, DT2=-1.234, VX=0.1234, VY=0.1234, VZ=0.1234, FOM=12.34, D1=23.45, D2=23.45, D3=
```

23.45,D4=23.45,BATT=23.4,SS=1567.8,PRESS=1.2,TEMP=12.3,STAT=0x000FFF
FFF*0B

Example (DF=409):

\$PNORWT9,1452244916.7508,1.234,-
1.234,0.1234,0.1234,0.1234,12.34,23.45,23.45,23.45,23.45,23.4,1567.
8,1.2,12.3,0x000FFFFFF*0B

13.3.2 DF100 - Prolog NMEA Format

See Prolog Data Format Description.

13.3.3 DF101/DF102 - NMEA Format 1 and 2

Information Data:

Identifier:

PNORI1 for DF = 101

PNORI2 for DF = 102

Field	Description	TAG	Data format	Example
Instrument type	4 = Signature75	IT	N	IT=4
Head ID		SN	N	SN=123456
Number of Beams		NB	N	NB=3
Number of Cells		NC	N	NC=30
Blanking Distance	[m]	BD	dd.dd	BD=1.00
Cell Size	[m]	CS	dd.dd	CS=5.00
Coordinate System		CY	ENU,BEAM,XYZ	CY=BEAM

Example (DF=101):

```
$PNORI1,4,123456,3,30,1.00,5.00,BEAM*5B
```

Example (DF=102):

```
$PNORI2,IT=4,SN=123456,NB=3,NC=30,BD=1.00,CS=5.00,CY=BEAM*68
```

Sensors Data:

Identifier:

PNORS1 for DF = 101

PNORS2 for DF = 102

Field	Description	TAG	Data format	Example
Date		DATE	MMDDYY	DATE=083013
Time		TIME	hhmmss	TIME=132455
Error Code		EC	N	EC=0
Status Code		SC	hhhhhhh	SC=34000034
Battery Voltage	[V]	BV	dd.d	BV=23.9
Sound Speed	[m/s]	SS	ddd.d	SS=1500.0
Heading	[deg] [unused]	H	ddd.d	H=123.4

Field	Description	TAG	Data format	Example
Heading Std.Dev	[deg] [unused]	HSD	dd.dd	HSD=0.02
Pitch	[deg] [unused]	PI	dd.d	PI=45.6
Pitch Std.Dev	[deg] [unused]	PISD	dd.dd	PISD=0.02
Roll	[deg] [unused]	R	dd.d	R=23.4
Roll Std.Dev.	[deg] [unused]	RSD	dd.dd	RSD=0.02
Pressure	[dBar]	P	ddd.ddd	P=123.456
Pressure Std.Dev	[dBar]	PSD	dd.dd	PSD=0.02
Temperature	[deg C]	T	dd.dd	T=24.56

Example (DF=101):

```
$PNORS1,083013,132455,0,34000034,23.9,1500.0,123.4,0.02,45.6,0.02,R
=23.4,0.02,123.456,0.02,24.56*39
```

Example (DF=102):

```
$PNORS2,DATE=083013,TIME=132455,EC=0,SC=34000034,BV=23.9,SS=1500.0,
H=123.4,HSD=0.02,PI=45.6,PISD=0.02,R=23.4,RSD=0.02,P=123.456,PSD=0.
02,T=24.56*3F
```

Current Data:

Identifier:

PNORC1 for DF = 101

PNORC2 for DF = 102

The current data is output for each measurement cell.

Field	Description	TAG	Data format	Example
Date	Date	DATE	MMDDYY	DATE=083013
Time	Time	TIME	hhmmss	TIME=132455
Cell Number	#	CN	dd	CN=3
Cell Position	[m]	CP	dd.d	CP=11.0
Velocity East	[m/s] Only if CY=ENU	VE	dd.ddd	VE=0.332
Velocity North	[m/s] Only if CY=ENU	VN	dd.ddd	VN=0.332
Velocity Up	[m/s] Only if CY=ENU and #beams >= 3	VU	dd.ddd	VU=0.332
Velocity Up2	[m/s]	VU2	dd.ddd	VU2=0.332

Field	Description	TAG	Data format	Example
	Only if CY=ENU and #beams = 4			
Velocity X	[m/s] Only if CY=XYZ	VX	dd.ddd	VX=0.332
Velocity Y	[m/s] Only if CY=XYZ	VY	dd.ddd	VY=0.332
Velocity Z	[m/s] Only if CY=XYZ and #beams >= 3	VZ	dd.ddd	VZ=0.332
Velocity Z2	[m/s] Only if CY=XYZ and #beams = 4	VZ2	dd.ddd	VZ2=0.332
Velocity Beam 1	[m/s] Only if CY=BEAM	V1	dd.ddd	V1=0.332
Velocity Beam 2	[m/s] Only if CY=BEAM and #beams >=2	V2	dd.ddd	V2=0.332
Velocity Beam 3	[m/s] Only if CY=BEAM and #beams >=3	V3	dd.ddd	V3=-0.332
Velocity Beam 4	[m/s] Only if CY=BEAM and #beams =4	V4	dd.ddd	V4=-0.332
Amplitude Beam 1	[dB]	A1	ddd.d	A1=78.9
Amplitude Beam 2	[dB] Only if #beams >=2	A2	ddd.d	A2=78.9
Amplitude Beam 3	[dB] Only if #beams >=3	A3	ddd.d	A3=78.9
Amplitude Beam 4	[dB] Only if #beams =4	A4	ddd.d	A4=78.9
Correlation Beam 1	[%]	C1	dd	C1=78
Correlation Beam 2	[%] Only if #beams >=2	C2	dd	C2=78
Correlation Beam 3	[%] Only if #beams >=3	C3	dd	C3=78
Correlation Beam 4	[%] Only if #beams =4	C4	dd	C4=78

Example (DF=101 (ENU, 3 beams):

```
$PNORC1,083013,132455,3,11.0,0.332,0.332,0.332,78.9,78.9,78.9,78,78,78*46
```

Example (DF=102 (ENU, 3 beams):

```
$PNORC2,DATE=083013,TIME=132455,CN=3,CP=11.0,VE=0.332,VN=0.332,VU=0.332,A1=78.9,A2=78.9,A3=78.9,C1=78,C2=78,C3=78*6D
```

Example (DF=102 (BEAM, 4 beams):

```
$PNORC2,DATE=083013,TIME=132455,CN=3,CP=11.0,V1=0.332,V2=0.332,V3=-0.332,V4=-0.332,A1=78.9,A2=78.9,A3=78.9,A4=78.9,C1=78,C2=78,C3=78,C4=78*49
```

13.3.4 DF103/DF104

Header Data:

Identifier:

PNORH3 for DF = 103

PNORH4 for DF = 104

Field	Description	TAG	Data format	Example
DATE	Date	DATE	YYMMDD	DATE=161109
TIME	Time	TIME	HHMMSS	TIME=143459
EC	Error Code	EC	D	EC=0
SC	Status Code (hex)	SC	HHHHHHHH	SC=204C0002

Example (DF=103):

```
$PNORH3,DATE=161109,TIME=143459,EC=0,SC=204C0002*28
```

Example (DF=104):

```
$PNORH4,161109,143459,0,204C0002*38
```

Sensors Data:

Identifier:

PNORS3 for DF = 103

PNORS4 for DF = 104

Field	Description	TAG	Data format	Example
Battery Voltage	[Volts]	BV	ff.f	BV=23.6
Speed of Sound	[m/s]	SS	fff.f	SS=1530.2
Heading	[deg] [unused]	H	f.f	H=56.7
Pitch	[deg] [unused]	PI	f.f	PI=3.4
Roll	[deg] [unused]	R	f.f	R=-3.4
Pressure	[dBar]	P	f.fff	P=6.789
Temperature	[deg C]	T	f.ff	T=23.30

Example (DF=103):

```
$PNORS3,BV=23.6,SS=1530.2,H=0.0,PI=0.0,R=0.0,P=0.000,T=23.30*64
```

Example (DF=104):

```
$PNORS4,23.6,1530.2,0.0,0.0,0.0,0.000,23.30*66
```

Current Data:

Identifier:

PNORC3 for DF = 103

PNORC4 for DF = 104

The current data is output for each measurement cell.

Field	Description	TAG	Data format	Example
Cell Position	[meters]	CP	f.f	CP=1.5
Speed	[m/s]	SP	f.fff	SP=1.395
Direction	[deg]	DIR	f.f	DIR=227.1
Correlation	[%]	AC	u	AC=32
Amplitude	[dB]	AA	u	AA=32

Direction is the angle calculated by $\text{atan2}(\text{velY}, \text{velX})$ and is referenced to the X-axis.

Example (DF=103):

```
$PNORC3,CP=1.5,SP=1.395,DIR=227.1,AC=32,AA=32*0D
```

```
$PNORC3,CP=2.5,SP=1.275,DIR=228.1,AC=35,AA=32*09
```

```
$PNORC3,CP=3.5,SP=1.256,DIR=240.9,AC=35,AA=32*0F
```

Example (DF=104):

```
$PNORC4,1.5,1.395,227.1,32,32*7A
```

13.4 DVL Altimeter ASCII Formats

13.4.1 DF200/DF201 - NMEA Format 200 and 201

Altimeter Data:

PNORA for DF = 200 and 201.

DF201 includes tags.

Field	Description	TAG	Data format	Example	
DATE	Date	DATE	YYMMDD	161206	
TIME	Time	TIME	HHMMSS	094717	
P	Pressure [dBar]	P	f.fff	1.234	
A	Altimeter [m]	A	f.fff	49.401	
Q	Quality	Q	U	12345	
ST	Status, Hexadecimal		ST	HH	08 - one beam
	Bit #	Description			
	0	Pitch or Roll > 5 deg			
	1	Pitch or Roll > 10 deg			
	2	NA			
6-3	# beams				

Example (DF=200):

```
$PNORA,161206,094717,0.000,49.401,17081,08*43
```

Example (DF=201):

```
$PNORA,DATE=161206,TIME=094737,P=0.000,A=49.404,Q=14447,ST=08*0F
```

13.4.2 DF202 - NMEA Format 202

Standard “Depth below Transducer” NMEA sentence.

```

1      2 3      4 5      6 7
|      | |      | |      | |

```

`§--DBT,x.x,f,x.x,M,x.x,F*hh<CR><LF>`

Field Number:

1. Depth, feet
2. f = feet
3. Depth, meters
4. M = meters
5. Depth, Fathoms
6. F = Fathoms
7. Checksum

Example (DF=202):

`§SDDBT,162.01,f,49.38,M,27.00,F*31`

13.4.3 DF203 - NMEA Format 203

Standard “Depth below Surface” NMEA sentence. This is output when the [fast pressure](#) function is enabled.

```

1      2 3      4 5      6 7
|      | |      | |      | |

```

`§--DBS,x.x,f,x.x,M,x.x,F*hh<CR><LF>`

Field Number:

1. Depth, feet
2. f = feet
3. Depth, meters
4. M = meters
5. Depth, Fathoms
6. F = Fathoms
7. Checksum

Example (DF=203):

`§SDDBS,162.01,f,49.38,M,27.00,F*31`

14 Troubleshooting

This section contains information on where to start looking if an instrument does not behave as intended. If you encounter a problem, you should:

- Get a good overview of the problem; make notes during the troubleshooting process.
- Work in a systematic way and do not neglect the obvious. Start by looking at simple causes, such as power not connected, bad connections, etc.
- If the setup uses custom cables, power supply, etc. first assemble and test the DVL using the cable that originally came with the instrument. You can always return to the standard setup, which is the easiest way to get the system to work and confirm that the problems are not caused by a faulty instrument.
- If your instrument behaves strangely try updating both your software and firmware to the latest versions. There may be incompatibility between an older version of firmware and newer version of software, and vice versa. The maintenance page will show if the versions of firmware and Applications/Documentations are up to date when accessed from a computer that is also connected to the internet. Clicking on the Check for Updates button will make sure the version status is downloaded over internet. MIDAS has a similar option in the Help menu > Check for updates. This will check for new releases of the MIDAS software when the computer is connected to Internet. The release state of the instrument firmware is checked at the same time if MIDAS is connected to an instrument.

To help us give good support, please

- Be specific about the error - a screenshot is often helpful.
- Include a sample file showing the error if possible.
- Include information about firmware and software version used.
- Include serial number (Head ID, Hardware ID or order number).
- A **Support file** can be downloaded from the instrument and is used by Nortek to assist you in the best possible manner. To retrieve this file through the web browser interface, click on the Maintenance tab. A *.gz file is then downloaded and can be sent directly to Nortek for diagnosis.

If it turns out that the instrument will have to be sent back to Nortek for repair, check out [this link](#) for more information and contact Nortek Support. There is a copy of the required Proforma Invoice for the return in the [Appendices](#).

NOTICE TO IMPORTER: The imported goods may be subject to restrictions if re-exported from your country. The goods are controlled by the following export control dual-use codes:6A001.b.2

14.1 Communication

Instrument connected through Ethernet cable

- Does the Ethernet cable have a source of power?
- Check network cabling connection: If your computer has light emitting diodes (LEDs) next to the connection where the Ethernet cable plugs into the computer, check if the LEDs are lit to indicate the current status of the network device. If the LEDs are not glowing/blinking, check that the connector is ok and try to re-plug. Refer to your computer's manual for information about the Ethernet port LED.

- Check the LED on the switch or router. The LEDs should be lit when there is a connection between the computer, the network router or switch and the instrument. If not, try switching it on and off to reset the switch/router.
- If an Ethernet switch is used, it's Ethernet port should also show an active Ethernet link. Try connecting with a different cable. If not, there is a problem with the computer connection.
- If you have a button for turning on/off the wireless network antenna on your computer, turn this off.
- Connect the communication cable directly from the computer to the instrument to bypass all of the network wiring and router. Is the PC showing that the link is active? Wait a minute or two and check again.
- If the connection was lost all of a sudden; run a test and analysis function in Windows (see step-by-step description below).
- If the instrument is visible in the Windows Explorer: Send a Break in the terminal emulator, then Switch to Command Mode. A confirmation message should now appear. Try connecting to the instrument as per normal. Check the [Integrators Interfaces](#) section for more information about the command interface.



Test and Analysis function in Windows:

1. Click "Start".
2. Click "Control Panel".
3. Click "Network and Sharing Center".
4. Click "Change Adapter Settings".
5. Right-click "Local Area Connection". This icon represents your Ethernet connection to the instrument.
6. Click "Diagnose." The analysis function in Windows will examine the failed connection and show an explanation of the problem and advice to fix the problem.

Unlike the serial port, once you have verified that the link is active, there is no need to do anything else with configuring the speed or other link characteristics. The next step is to make sure you have an appropriate IP address assigned. For details about the process of assigning IP addresses, refer to the [Appendix](#).

Instrument is connected through serial communication cable

- Does the instrument have a source of power?
- Wrong serial port. Check that the correct serial port is selected. Go to Start - Control Panel - Systems - Hardware - Device Manager - Ports (look for USB device).

- Wrong baud rate. Open a terminal emulator and try to cycle the power on the serial connection. If gibberish/nonsense or nothing, check the baud rate settings.
- There is a problem with the converter. Check that the LED on the converter is lit. If not, confirm that the correct driver is installed.

The blue LED indicator light on the instrument is not lit

- Is the instrument in Command mode?
- Does the LED blink (short) when applying power?
- Has the LED been disabled in the most recent configuration?

Cable

Cables are often exposed to heavy use and power connectors sometimes break. Using a multimeter to test pin to pin through the cable may reveal breakage.

14.2 Network

Firewall

Firewalls are usually active by default and could be a possible cause for blocking communication.

Routers

There are some limitations to the discovery protocol. Multicast Ethernet packets are used to implement the protocol and those packets may not be forwarded through routers (depending on the router type and configuration). For that reason, the instrument should be either directly connected or connected through a single Ethernet switch for troubleshooting. Once the IP address is properly configured, it can be used to access the instrument using normal IP communications. Only the discovery protocol uses multicast packets. For more details about the Ethernet communication, refer to the [Appendix](#).

Backup if the web site crashes

There is a way to reboot the network processor even if the WEB page is not working. Click on Discover from MIDAS or Nortek Discovery, click on the instrument to get the configuration and then right click in the configuration window. This brings up a menu where you can select to Reboot Network Processor. The support file can also be retrieved this way. We prefer to read this file before the reboot so we can attempt to diagnose the cause.

IP address

You have the possibility to enable/disable DHCP and set a static IP address, if necessary. Check out the [Appendix](#) for more details.

14.3 Bottom Track

In order to detect the bottom, a transmitted ping must have return characteristics that provide a sufficiently high enough score to qualify it as a valid bottom detection. Once the bottom detection is made, the velocity along the beam is calculated. This means that any number of beams may have valid estimates of velocity, however in order to report a complete XYZ estimate of velocity, the DVL needs to have a minimum of three beams with valid bottom detections.

The lack of consistent bottom detection may be attributed to a variety of reasons:

- Acoustic interference from other acoustic instrumentation operating in the same frequency band (25% band centered on DVL transmit frequency). Other acoustic instrumentation may also produce harmonics which interferes with bottom detection. In order to identify acoustic (or electronic sources) of noise, one may consider using the Spectrum Analyzer function of the DVL. This works together with the MIDAS software. Further documentation of this functionality and testing is found in the [Appendix](#).
- Highly reverberating environments such as buckets, tanks, and other small enclosures.
- Poor acoustic return from bottom tracking surfaces such as (a) soft sediment bottoms, (b) seaweed rich bottoms, (c) or extreme bottom slopes.
- Highly scattered transmit pulse for environments that are rich in bubbles: (a) propeller wash, (b) breaking waves which may produce bubbles in the first several meters of the water column, (c) schools of fish.
- Extremely close to the bottom.
- Bottom is out of range or configured range of DVL.
- False detections may occur from time to time, particularly at short range when traveling near the surface where there normally is high particle (or bubble) concentrations (first 10 m or so). This is especially true when the true bottom is out of range.

One way of avoiding false detects is to configure the blanking distance and/or the maximum range so that it looks for the bottom within a known window. For example, if the vehicle is not going to operate closer than 5 m from the bottom, the blanking distance can be set to e.g. 3 m. This will eliminate all detections within the first 3 meters. The larger the blanking distance, the lower the probability of false detections. A remember that anything inside the blanking distance is invisible to the DVL.

Highly reverberant environments may also benefit by reducing the transmit power. This is of course done at the expense of the bottom detection at greater ranges.

14.4 Software

Discovery tool

The instrument I want to connect to has a red background.

The instrument cannot be connected to because of one of the following reasons:

- Non compatible firmware. Upload it through the web browser interface or MIDAS (click Upgrade)
- Instrument is on wrong subnet. This can be fixed automatically by double-clicking the instrument name while in the Discovery screen.
- The instrument listed is not supported by the software.

If the Discovery feature does not list your instrument, refer to the [Communication Problem](#) section.

Software crash

- Download the support file containing debug information. (Through the web browser interface: find it under Maintenance. Through MIDAS: available through the operations menu.
- If your instrument behaves strangely (for example, error messages when trying to start data collection, compass calibration or pressure offset calibration), update both your software and firmware to the latest versions. There can be incompatibility between an older version of firmware and newer version of software, and vice versa. The latest versions of firmware and software can be downloaded from our support page.

15 Appendices

15.1 Glossary

Accuracy	A value giving the degree of closeness of a velocity measurement to the actual velocity. Refer to the data sheet for specific minimum accuracy.
AD2CP	Nortek's broadband signal processing platform.
.ad2cp	Nortek raw binary data file
Amplitude (*)	See signal strength
ASCII output	Data is displayed in ASCII format (text).
Bandwidth	Wider signal bandwidth is used to get more information and improve the velocity precision.
Beam Coordinates	Bottom track: The reported velocities are positive when the motion is towards the transducer. Current profile: The reported velocities are positive when the motion is away from the transducer.
Blanking	Specifies the distance from instrument head to the start of the measurement cell where no measurements take place, to give the transducers time to settle before the echo returns to the receiver. The size of the blanking area is user selectable in the software using the Start of profile parameter.
Bottom Track	Bottom tracking is a method where the velocity of the bottom is measured. The bottom track algorithm is a "single mode" and functions from the minimum depth to the maximum depth, seamlessly.
Break	A break command is used to change between the various operational modes of the instrument and to interrupt the instrument regardless of which mode it is in. When break is received in command mode, you can see that the LED is switched off for a short time.
Broadband	In this context it means using a more complex transmit pulse to improve the measurement accuracy in each ping.
Cell (*)	One measurement cell represents the average of the return signal for a given period. The cell size and transmit pulse are of equal size.
Command mode	An instrument in command mode is powered up and ready to accept your instructions. If no commands are received for about five minutes, it automatically goes into Power Down Mode, unless Ethernet power is connected. LED is lit constantly when in command mode.
Connector Lubricant	MOLYKOTE® 44 Medium.
Correlation (*)	Nominal correlation is a function of cell size and velocity range. Nortek recommends using 50% of the max correlation as a cut-off value, beyond this point the validity of your data is questionable.
Desiccant Bag	Added in the canister to absorb humidity

Firmware	Internal software of the instrument, as opposed to the instrument software running on a PC. Availability of new firmware versions is shown on the instrument web interface.
FOM (Figure of Merit)	Measure of the velocity white noise level (single ping precision).
Internal sampling rate	Rate of sampling for internal sensors. Refer to the specific instrument brochure for details.
LED	Light Emitting Diode.
License	Different capabilities of the instrument are protected under licenses which can be purchased. Contact your sales representative for more information. You will not need a license when updating the firmware version.
MIDAS	Nortek Multi-Instrument Data Acquisition Software
NMEA	Standard data format defined by the National Marine Electronics Association
Noise floor	The amplitude of the internal noise of the instrument. This will limit the minimum detectable signal that can be received.
O-ring lubricant	Molykote 111.
.pd0	Data format defined by RDI, that has been available for a long time. Format is described in RDI Workhorse manual.
Ping	Same as a single transmit pulse.
Precision (*)	The value given is a theoretical estimate of the precision of the velocity measurements based on how the instrument is set up. The nominal value is given for the horizontal components in a default instrument acoustic beam configuration. In order to improve the precision the user may consider one of the following options: (1) larger cell sizes or (2) reduced velocity range
Pressure Offset	Due to atmospheric pressure variations, the sensor signal may have an offset. Note that the sensor does not output negative values. Set the offset before deployment.
Sidelobe	The acoustic beams focus most of the energy in the center of the beams, but a small amount leaks out in other directions. Transducer sidelobes are rays of acoustic energy that go in directions other than the main lobe. Because sound reflects stronger from the water surface than it does from the water, the small signals that travel straight to the surface can produce sufficient echo to contaminate the signal from the water.
Signal strength	Strength of return signal, presented in dB.
SNR	SNR is the Signal-to-Noise ratio and is a data quality indicator.
Trigger	A signal to wake up/get attention. In addition to the internal there are two external options: RS485 and TTL trigger.
XYZ Coordinates	Cartesian coordinate system. A positive velocity in the X-direction goes in the direction of the X-axis arrow. Use the right-hand-rule to remember the notation conventions for vectors. Use the first (index) finger to point in the direction of positive X-axis and the second (middle) finger to point in the direction of positive Y. The positive Z-axis will then be in the direction that the thumb points.

(*) Relevant for current profiling only.

15.2 Communication and Ethernet

Connections between the instrument and computer can be made in one of two ways.

- Ethernet (via direct connection or router/switch)
- RS232/RS422 through the serial port. Serial communication baud rate: 300-115200, 230400, 460800, 625000, 1250000

Details about the Ethernet connection

The first time using the instrument, the network address needs to be properly configured for the network. The IP address can be assigned in one of three ways:

1. Dynamic Host Configuration Protocol (DHCP): A DHCP server in the network is used to assign an IP address to the Ethernet interface.
2. AutoIP: Link-local address assignment.
3. Manually assign IP address (by the user)

As shipped, the instrument uses options 1 and 2. This means that it will try to automatically configure the IP address for the network the instrument is plugged into.

If a DHCP server is detected it takes approximately 30 seconds to negotiate for and assign an IP address to the Ethernet interface. If you are using a broadband router, it is likely you are using a DHCP Server to assign IP Addresses. Common private network address schemes include 192.168.x.x and 10.0.x.x subnets, with the Subnet mask of 255.255.255.0 or 255.255.0.0

If a DHCP server is not detected (usually because of being directly connected to a computer) and the request for an IP Address is not fulfilled, the instrument will automatically assign itself IP addresses using the AutoIP protocol. DHCP must first time out before the AutoIP protocol starts, so this will result in a delay of approximately 90 seconds before an IP address is finally assigned. A standard AutoIP address sits in the 169.254.x.x range, with the subnet mask being 255.255.0.0.

When using automatic IP address assignment, there is generally no way of knowing which address was assigned to the instrument. To determine the IP address assigned, the Discovery protocol is used to query instruments on the local subnet. The discovery protocol is a Nortek proprietary means for retrieving information from an AD2CP without requiring any knowledge of the IP address assigned.

There are some limitations on the Discovery protocol. It uses a special type of Ethernet packets (known as multicast packets) that may not be forwarded through routers (depending upon the router type and configuration). For that reason, we always recommend that the computer being used for Discovery ONLY be either directly connected to the instrument or connected through an Ethernet switch. Only the Discovery protocol uses multicast packets. Other communications use standard TCP/IP networking which means that the instrument can be communicated with anywhere that IP connectivity is supported once the IP address is known.

For more details about the DHCP or AutoIP please reference articles available in the public domain. These are standard protocols used by most Internet based equipment.

Routers

The discovery protocol uses multicast packets that may not work through firewalls and routers. The Time-to-Live for the multicast packets is set to 2. This means that at most one router can sit between the acquisition system and instruments. The router must also be configured to support forwarding of multicast packets.

The discovery protocol also supports unicast, so if you know the IP address of the system you can use the Discover > Search for Address and simply type in the IP address or domain name.

Manually assign IP address

Networked instruments can also have their IP address manually assigned. This may be useful on networks in which the discovery protocol might not work (e.g. through multiple routers or firewalls).

Network Configuration

Click the highlighted instrument in the Instrument Search dialog to get the option of enabling DHCP or set a static IP address or IP address for a local interface (see section [Finding Instrument on PC](#) for description of parameters), or check out the MIDAS software manual.

15.3 BIT Test

Description of Built In Test (BIT)

The Built in Test is a DVL internal test to verify functionality of the instrument. The output provides an overview of system status, sensor health, and general functionality. It is by no means exhaustive nor is it conclusive but provides an indication of possible issues. The most challenging element of the evaluation is determining the transducer functionality. The reason for this is that the DVL may be exposed to strong environmental noise (often found in a workshop/lab), and this may confound the conclusion. The tests are intended to indicate if there is a low enough noise level to achieve reasonable bottom track, and for this reason the tests must be run with the DVL submerged in water. Saltwater is preferred (improves grounding and representative of the operating environment), and the tank should be as large as possible. A large bucket will work but may make the test interpretation difficult.

Instructions for testing the DVL

1. Connect the DVL to power and comms, this may be done directly to a PC or through a paired instrument, such as an INS.
2. Submerge the DVL in water. For 300m variants, ensure that the grounding plate is also submerged.
3. If connected through Ethernet comms, then one may simply navigate to the Maintenance page in the DVL's web browser interface and click on the "Retrieve Support File" button. Clicking this button starts the Built In Test which runs for approximately 5 seconds. We recommend keeping the instrument submerged until the support file is compiled and available for download.

Interpretation of BIT Output

The Following is an example of the Built In Test (BIT) for the Nortek DVL. This example was conducted using a DVL 500.

Built In Test Report

Test time: 2025-05-19 14:13:05

1 Version information:

Firmware version: 4054_5/187 (Jan 27 2025 21:34:06)
 Bootloader version: 24

2 Hardware configuration:

Instrument: NortekDVL_500
 Serial no.: 103136
 Frequency: 500 kHz
 Number of beams: 4
 Digital board version: I-3 Interface board version: J-1 Analog board version: B-1(Low-Power mini) /Channel5ExtDynamics/LowGain
 Sensor board version: I-0 /TemperatureRail /PressureRail

Interpretation: None, this is the system description.

3 Sensor configuration:

Temperature
 Pressure N113645

Interpretation: This lists the auxiliary sensors configured for operation.

4 Licensed features:

Bottom Track
 16GB Recorder

Interpretation: This details the licensed features. A Standard DVL will have Bottom Track enabled and a 16GB recorder. Optional features that will also appear in this section if purchased are Averaging Mode (Current Profile) and a 64GB Recorder (larger recorder).

5 Noise profile test slanted beams:

Cell	VelB1	VelB2	VelB3	VelB4	CorrB1	CorrB2	CorrB3	CorrB4	AmpB1	AmpB2	AmpB3	AmpB4
1	4.274	-3.276	0.724	-5.427	8	7	8	8	27.5	27.5	27.5	27.5
2	-2.666	3.223	-0.319	2.136	3	4	9	11	27.5	28.0	27.0	27.5
3	-1.921	0.430	5.592	-0.021	3	9	3	10	27.5	27.5	27.5	27.0
4	4.162	-3.964	2.559	-2.134	11	4	6	8	27.0	27.5	27.0	27.5
5	-3.090	0.818	3.901	1.760	15	13	6	2	27.0	28.0	27.0	27.5
6	0.283	3.557	-0.134	0.630	5	15	13	10	27.5	27.5	27.5	27.5

7	-4.546	4.768	-1.298	2.153	6	3	15	4	27.0	28.0	27.5	27.5
8	-1.410	2.974	-5.365	0.412	4	13	4	12	27.5	27.5	27.0	27.5
9	0.484	-2.543	-5.249	0.338	5	9	6	12	28.0	27.5	26.0	27.5
10	-3.427	4.577	1.131	1.696	3	11	7	8	27.5	27.5	27.0	27.5
11	-2.894	-0.688	-2.373	-2.180	3	13	5	10	28.0	28.0	27.0	27.5
12	-1.487	-0.825	0.441	-0.504	8	15	9	6	27.5	28.0	27.5	27.5
13	5.016	0.852	-1.023	-0.299	12	4	1	2	28.0	28.0	27.5	27.5
14	0.781	-5.303	3.511	1.155	2	15	5	11	28.0	27.5	27.5	28.0
15	0.112	-2.029	0.392	-2.570	3	6	6	7	27.0	27.5	28.0	27.5
16	2.557	1.086	1.024	0.574	5	3	9	7	27.0	27.5	27.5	26.5
17	1.483	-2.280	4.178	0.406	0	3	5	10	27.5	28.0	27.5	27.0
18	-2.520	1.656	-2.806	-3.641	4	12	7	8	27.5	27.5	26.5	28.0
19	-2.365	-0.527	-1.024	3.914	2	3	10	7	27.5	27.5	27.5	28.0
20	-0.264	-1.379	3.724	-2.703	6	6	5	2	28.0	28.0	27.5	27.0
21	3.309	2.150	-2.014	1.774	2	7	2	9	27.5	28.0	28.0	27.0
22	2.847	1.663	-4.996	2.444	7	13	6	11	28.0	28.5	28.0	27.5
23	2.348	-4.032	-2.137	-3.777	10	13	2	10	28.0	27.5	28.5	27.5
24	1.952	-2.473	0.788	-1.264	2	1	6	4	28.0	27.5	28.0	27.5
25	0.016	1.389	-1.301	-1.593	0	4	3	2	27.5	28.0	27.5	27.5
26	-1.777	3.753	-2.320	3.506	7	0	10	3	28.0	27.5	28.0	27.5
27	2.967	-5.324	2.234	1.564	2	7	10	10	27.0	27.5	27.5	27.0
28	-2.553	2.957	-0.657	1.793	7	6	5	5	27.5	27.5	27.0	28.0
29	-5.260	-2.303	4.435	-2.428	10	6	9	7	27.5	28.0	27.0	27.0
30	2.633	2.833	-1.707	3.302	17	6	7	10	27.0	27.5	27.0	27.5
31	-1.471	1.716	1.360	4.695	2	7	9	7	28.0	27.5	27.5	27.5
32	-0.867	-1.520	-4.935	-0.172	6	12	6	5	27.5	28.0	28.0	27.5
33	-3.201	-3.924	-2.282	-1.731	7	6	4	17	28.0	27.5	27.5	27.0
34	-0.424	5.257	3.049	-2.163	6	6	4	1	28.0	27.5	27.5	27.0
35	2.531	1.287	2.629	1.325	2	2	5	10	27.0	27.5	27.5	27.5
36	5.098	2.590	-5.261	-1.913	4	5	13	3	27.5	28.0	27.5	27.5
37	2.876	-0.080	-3.861	-3.884	11	8	7	11	27.5	27.0	27.0	28.0
38	-3.159	1.344	2.596	-4.258	14	5	2	15	28.0	28.0	27.5	27.5
39	3.300	3.530	4.171	4.436	1	8	10	10	28.0	28.0	28.0	27.5
40	4.934	-1.856	3.045	-0.662	5	16	7	8	27.5	28.0	28.5	27.5
41	0.155	-3.452	0.600	3.833	8	7	8	13	26.5	27.5	27.5	27.5
42	1.650	-3.991	4.452	0.702	8	1	10	1	28.0	27.5	27.0	27.5
43	0.065	-3.297	2.607	4.548	4	3	3	7	28.5	27.0	27.0	28.0
44	3.274	4.997	3.625	-4.413	1	5	4	7	28.0	28.0	27.0	27.5
45	1.992	2.921	-3.968	-1.533	7	11	3	10	27.5	27.5	27.5	28.0
46	-3.006	3.002	-1.665	3.886	4	6	3	12	27.5	28.0	27.5	28.0
47	-2.087	-2.842	5.044	-4.007	6	0	10	1	27.5	27.0	28.0	27.5
48	-5.312	0.752	1.866	-1.051	1	1	6	1	27.5	28.0	27.0	28.0
49	-3.816	3.710	4.310	2.938	10	9	9	6	27.5	27.5	27.5	27.5

50	-1.726	-3.700	3.820	-1.814	9	1	3	3	27.0	27.0	27.0	28.0
51	4.768	-3.555	-4.253	-0.685	8	2	6	5	27.5	27.5	27.5	27.5
52	-3.358	4.447	3.403	1.551	4	11	10	5	28.0	27.0	28.0	27.0
53	-1.711	1.131	-0.676	-4.310	2	11	12	5	28.0	27.5	27.5	27.5
54	-2.032	-4.601	4.057	3.697	8	9	10	5	27.5	27.0	28.0	27.0
55	-2.384	-1.814	2.022	2.794	7	1	14	8	27.5	27.5	27.5	28.0
56	-4.243	2.895	2.316	0.197	1	8	0	7	28.0	27.0	27.5	28.0
57	-0.655	-0.981	4.130	5.238	1	5	8	6	27.5	28.0	27.5	27.5
58	0.954	1.647	-4.214	-0.463	1	4	0	6	27.5	28.0	28.0	27.5
59	3.009	2.712	-5.674	0.437	1	13	1	7	27.5	27.0	27.5	27.5
60	3.485	3.401	0.662	1.234	4	6	10	4	28.0	27.0	27.5	27.0
61	0.962	1.201	0.845	-3.857	5	4	17	6	28.0	28.0	27.5	27.5
62	-1.995	0.257	-1.359	-0.797	3	5	3	13	27.5	28.5	27.5	27.5
63	-4.953	1.260	1.554	-2.258	2	4	8	19	28.0	27.5	27.5	28.0
64	1.019	0.394	-1.552	3.966	1	1	10	6	27.5	28.0	28.0	27.5
65	-5.301	2.974	-2.054	-2.472	6	4	1	6	28.0	27.0	28.0	27.0
66	-5.057	-4.358	4.450	1.002	6	15	6	9	27.0	28.0	28.0	28.0
67	3.249	0.629	4.240	1.262	7	6	5	4	28.0	27.5	27.0	28.0
68	-2.396	-3.800	-1.973	0.073	9	15	4	7	28.0	27.5	28.0	27.5
69	-0.186	-2.681	-4.256	-3.978	2	5	0	0	27.0	28.0	28.0	27.5
70	4.050	5.015	-0.807	-3.237	18	4	6	8	28.0	28.5	27.0	27.5

Interpretation: This test is intended to provide an indication of the noise levels, which is a combination of the noise from the DVL itself, effects from connected systems, and the environmental noise – both electric and acoustic.

This test is run with the transmitter turned off, i.e. listening only, and provides a profile for each of the beams and reports values of velocity, correlation, and amplitude. It is intended to provide an indication of noise exposure. High noise levels can reduce the range and noise that is colored may bias the velocity estimates. Since the DVL is not transmitting the velocity values shown in the test are not valid and should be ignored.

An ideal system (depending on model) will have amplitude levels of 23-32 dB.

Note that this noise is the noise perceived by the DVL and indicates not only the systems self-generated noise, but also noise resulting from noisy power supplies, neighboring acoustic devices, and environmental noise which may be present in the test facility/laboratory.

- 5.1 Results beam 1:
 Mean velocity = -0.185 m/s
 Std velocity = 2.966 m/s
 Mean correlation = 5.5 % PASSED
 Mean amplitude = 27.6 dB PASSED

Bottom track noise = 0.40 PASSED

- 5.2 Results beam 2:
Mean velocity = 0.205 m/s
Std velocity = 2.966 m/s
Mean correlation = 6.9 % PASSED
Mean amplitude = 27.7 dB PASSED
Bottom track noise = 0.40 PASSED
- 5.3 Results beam 3:
Mean velocity = 0.314 m/s
Std velocity = 3.130 m/s
Mean correlation = 6.5 % PASSED
Mean amplitude = 27.5 dB PASSED
Bottom track noise = 0.40 PASSED
- 5.4 Results beam 4:
Mean velocity = -0.012 m/s
Std velocity = 2.680 m/s
Mean correlation = 7.3 % PASSED
Mean amplitude = 27.5 dB PASSED
Bottom track noise = 0.41 PASSED

Interpretation: These summary values are a quick indication of the functionality of the acoustics.

A properly operating system should have a mean correlation below 20%. A correlation between 20-25% will result in a warning and over 25% will result in a fail.

Mean amplitude should have a value between 18-35dB. The test will output a warning if the value is within 15-18dB or 35-40dB. Values below 15dB or above 40dB will output as fail.

What should happen if a warning or fail is shown? The first step should always be to check the test setup. It is very likely that external noise is causing the issue, especially in an office or workshop environment. Move to an area with less interference and retry the test.

6 Boost operation measurements:

Cap bank pretest voltage = 50.43 V
Average boost energy = 1.64 J PASSED
Source resistance = 1.82 Ohm
Minimum input voltage = 23.19 V PASSED
Cap bank voltage = 68.75 V PASSED
Cap bank charge duration = 189.1 ms PASSED
Low input voltage status = OK PASSED

7 Internal transmit/receive loopback test:

- 7.1 Results beam 1:
 Velocity = 0.000 m/s PASSED
 Correlation = 100 % PASSED
 Amplitude = 103.0 dB PASSED

- 7.2 Results beam 2:
 Velocity = 0.001 m/s PASSED
 Correlation = 100 % PASSED
 Amplitude = 99.9 dB PASSED

- 7.3 Results beam 3:
 Velocity = 0.000 m/s PASSED
 Correlation = 100 % PASSED
 Amplitude = 98.0 dB PASSED

- 7.4 Results beam 4:
 Velocity = 0.000 m/s PASSED
 Correlation = 100 % PASSED
 Amplitude = 95.7 dB PASSED

Interpretation: The loop back test for the transmit receive should produce a near zero velocity on the four beams. Amplitude should be over 70dB.

8 Water current profile test:

Cell	VelB1	VelB2	VelB3	VelB4	CorrB1	CorrB2	CorrB3	CorrB4	AmpB1	AmpB2	AmpB3	AmpB4
1	-0.117	0.020	-0.007	0.016	99	100	100	98	115.0	115.0	113.0	114.0
2	-0.053	-0.038	-0.116	-0.079	95	93	85	89	110.0	109.0	103.0	106.0
3	-0.064	-0.001	-0.172	0.061	81	83	79	91	100.0	96.5	86.0	88.5
4	-0.022	0.108	-0.011	-0.067	78	72	80	85	82.5	78.0	71.5	73.0
5	0.009	0.103	-0.052	-0.011	91	90	85	90	68.5	68.0	61.0	61.0
6	0.004	0.105	-0.064	-0.056	86	88	89	86	54.5	53.0	50.0	47.5
7	0.062	0.027	0.051	-0.032	85	86	80	77	42.5	40.5	39.5	36.0
8	0.025	0.007	-0.026	-0.102	50	55	49	32	31.5	32.0	32.5	29.5
9	-0.367	-0.042	-0.189	0.814	17	12	24	12	28.0	28.5	28.5	26.5
10	0.166	1.598	4.269	-1.544	9	4	7	9	27.5	28.5	27.5	27.5
11	-4.450	1.774	-3.041	4.336	3	6	1	11	27.5	27.0	27.5	27.0
12	3.209	-2.619	2.313	-3.522	3	6	8	5	27.0	27.5	27.0	28.0
13	-2.040	2.047	0.911	-4.621	10	6	6	6	28.0	27.5	27.5	27.5
14	0.744	-1.751	-4.472	4.848	2	3	6	8	27.5	28.0	28.5	27.0
15	-1.746	-0.363	-2.303	-3.746	7	4	3	10	27.0	28.0	27.5	27.5
16	0.565	-4.908	-3.588	-3.894	2	1	9	11	28.0	27.5	27.5	27.5

17	3.167	4.865	3.310	-1.486	5	3	12	10	27.5	28.0	27.5	28.0
18	-3.144	-1.564	2.481	3.582	4	3	2	1	27.5	27.5	28.0	28.0
19	-0.660	1.121	-3.167	0.308	9	3	10	5	27.5	27.5	28.0	28.0
20	-4.874	4.166	1.678	4.036	9	9	5	3	27.5	27.5	27.0	28.0
21	-3.514	-3.437	-4.098	1.120	10	6	8	0	28.0	27.5	27.0	27.0
22	3.238	-1.523	-1.101	-2.152	8	4	10	4	27.0	27.5	27.5	28.0
23	3.830	1.166	2.437	2.197	1	10	4	4	27.5	28.0	27.5	27.5
24	4.815	4.517	-1.416	3.836	17	10	10	0	28.0	27.5	27.0	27.0
25	0.209	1.228	-0.016	3.598	8	8	11	3	28.0	27.0	27.5	27.5
26	-1.916	-0.181	1.650	-1.242	5	11	2	0	27.5	27.5	28.0	27.0
27	5.234	1.994	4.376	-3.230	1	5	21	6	27.5	28.0	28.0	27.5
28	3.185	-0.312	4.442	2.302	0	5	1	3	28.0	27.5	27.5	27.0
29	-5.413	3.771	3.687	-2.470	6	6	2	9	27.5	27.5	27.5	28.0
30	-0.916	-0.828	-0.339	-4.244	10	1	3	4	27.0	28.0	27.5	27.0
31	3.564	-4.994	2.573	-5.383	4	14	9	7	27.5	27.5	26.5	27.5
32	3.334	2.358	-1.321	-1.967	6	20	2	2	27.5	27.5	28.0	28.0
33	-4.092	3.970	2.256	-0.244	4	5	11	1	27.5	27.5	28.0	28.0
34	2.502	4.243	1.939	0.276	6	11	11	3	27.5	27.5	26.5	28.0
35	-3.712	1.984	3.515	-2.621	9	19	11	12	28.0	27.5	28.0	27.5
36	5.459	4.292	2.381	-2.642	7	3	1	2	28.0	28.0	26.5	28.0
37	-5.124	-3.753	-0.263	3.414	2	0	2	5	27.5	28.0	27.5	27.5
38	-1.568	-2.958	0.344	-0.705	1	1	8	7	28.0	27.5	27.5	27.5
39	0.320	4.795	2.046	-2.925	13	17	10	3	27.5	28.0	27.5	27.5
40	3.693	4.202	-2.835	2.915	13	10	12	3	27.0	27.5	27.5	27.5
41	-2.070	-5.252	-4.485	2.682	10	6	3	11	28.0	28.0	28.5	27.5
42	1.080	-3.712	1.668	-4.200	8	9	2	15	28.0	28.0	27.5	27.5
43	2.474	4.483	-1.165	0.366	3	4	2	4	28.0	28.0	27.5	27.5
44	-2.938	-0.278	-1.396	-2.693	10	3	8	12	27.5	28.0	27.5	28.5
45	0.584	-0.318	3.040	1.604	6	6	4	15	28.0	28.0	27.5	27.5
46	0.963	1.843	-0.711	-2.199	5	6	3	10	27.5	28.5	27.0	27.5
47	-2.964	1.407	-1.005	3.321	7	9	9	3	27.5	27.5	27.0	27.5
48	2.283	-0.059	-0.534	4.528	3	13	10	4	27.5	28.5	28.0	27.0
49	-1.965	-1.205	-1.136	-3.440	20	9	8	7	27.5	27.5	27.0	27.5
50	-2.415	-4.105	4.233	1.912	3	6	10	8	28.0	27.5	27.0	28.5
51	3.204	3.714	0.316	2.880	3	12	9	12	28.0	27.5	27.5	27.0
52	3.013	4.004	-5.323	2.602	10	16	15	1	27.5	28.0	27.0	27.5
53	-0.905	3.854	2.269	2.754	10	6	7	8	28.0	27.5	27.5	27.0
54	-4.910	2.424	0.644	-5.125	6	1	6	6	27.5	28.0	28.0	27.5
55	-1.104	-1.404	-0.414	2.577	4	6	14	7	27.0	27.5	27.0	27.0
56	-3.687	3.826	1.762	-1.649	12	1	6	1	27.5	27.5	27.5	27.5
57	-6.417	0.983	-2.547	-2.705	0	11	5	5	27.5	27.5	27.0	27.5
58	-3.592	-1.102	3.168	1.125	5	6	0	4	27.0	27.0	27.5	27.5
59	-3.139	-1.113	2.852	-4.479	1	8	6	13	28.0	27.5	27.5	28.0

60	4.220	2.290	3.948	1.959	2	9	0	4	28.0	27.5	27.5	27.0
61	-0.849	4.569	5.428	-3.102	16	5	9	9	28.0	28.0	28.0	27.5
62	-3.603	-2.634	-2.905	1.654	4	10	6	1	28.0	27.5	28.0	28.0
63	-3.870	-3.074	3.842	4.580	7	1	3	1	28.0	28.0	28.0	27.5
64	3.358	-4.040	4.332	4.147	4	8	5	4	27.0	27.5	28.0	27.0
65	3.970	-0.670	-2.825	-0.522	2	8	6	6	28.0	28.0	27.0	27.0
66	0.540	0.288	-2.523	2.182	9	10	12	8	27.5	27.5	27.5	28.0
67	-0.609	0.800	-1.922	4.648	6	3	10	10	28.0	27.5	28.0	28.0
68	-1.135	2.616	-1.590	-4.993	10	13	3	10	27.5	27.5	27.0	27.5
69	-1.991	3.166	-4.588	-0.979	2	4	9	3	27.5	27.0	27.5	28.0
70	-5.143	-0.045	-1.645	-0.343	3	9	4	18	27.5	28.0	28.0	28.0

Interpretation: This test is similar to the noise test, but now the transmitter is turned on. Amplitude values may be high, particularly in a test tank where the pulse may be reflected and received multiple times before dying out. The amplitude should attenuate with range with the exception of boundaries or objects providing reflection and multipath returns.

The portion of the profile which is of most interest is at the greatest extent of the range. Here is where the amplitude (and correlation) should reach a constant value and define the noise level. Higher levels correspond to elevated noise floors and consequently reduced range.

- 8.1 Results beam 1:
Correlation cell 3 = 81 %
Amplitude cell 3 = 100.0 dB
- 8.2 Results beam 2:
Correlation cell 3 = 83 %
Amplitude cell 3 = 96.5 dB
- 8.3 Results beam 3:
Correlation cell 3 = 79 %
Amplitude cell 3 = 86.0 dB
- 8.4 Results beam 4:
Correlation cell 3 = 91 %
Amplitude cell 3 = 88.5 dB

Interpretation: This test will be executed regardless of whether a current profiling license is installed. The third measurement cell from the instrument is used for the test. If testing in a tank, there may be interference with the boundaries causing reflections. If the goal of running the BIT test is to check current profiling, the test must be conducted in deep water so a proper current profile can be taken.

- 9 Measure transmit energy pr beam:
Transmit energy beam 1 = 76

Transmit energy beam 2 = 70

Transmit energy beam 3 = 70

Transmit energy beam 4 = 76

Interpretation: This tests the transmitter energy output. All beams should be within +/- 50% of the mean value.

10 Sensor measurements:

Internal temperature = 22.75 C

Water temperature = 21.74 C

Pressure sensor temperature = 21.00 C

Pressure sensor = 0.735 dBar

Pressure sensor (absolute) = 10.234 dBar

Interpretation: Internal temperature should be in the range of -4 – 60 C. The water temperature sensor is located in the DVL head. It should read within -4 – 30 C and display a reasonable value for the expected water temperature.

Pressure sensor temperature should be within 3 degrees of the Temperature.

Pressure sensor should be in the range of 5 – 50 dBar. Fail <5 and >100 Warning <8 and >50

Note that heading, pitch and roll sensors are disabled in DVL products.

11 Measure internal currents and voltages:

11.1 Power input:

Voltage = 23.99 V PASSED

Current = 10.87 mA (StdDev = 1.16 mA)

Power = 260.7 mW PASSED

11.2 Internal voltages:

5.3 V = 5.338 V PASSED

3.3 V = 3.264 V PASSED

Interpretation: Voltage should be between 12 – 48 volts. Near 12v can cause uncertainty in the estimates and risks powering down. Above 51V will damage the instrument.

15.4 Noise Troubleshooting

Intro to noise

Noise may be electronic or acoustic in origin, both of which will have a detrimental effect on DVL performance. This document presents a systematic way to characterize and measure noise sources, allowing the end user to methodically remove or isolate them. This document is by no means intended to be a complete or comprehensive treatment of the topic. It is intended to show the end user how to collect sufficient diagnostics with the Nortek DVL in order to evaluate the noise sources and begin a dialog to make improvements. The general process as follows.

1. Set transducers into a listening mode.
2. Disable all other systems on vehicle, leaving only the DVL and its intended power supply turned on.
3. Measure baseline noise.
4. Measure noise generated by other vehicle systems.
5. Use spectrum analyzer to identify the frequency and source of any noise identified in previous steps.

Electrical noise is an inherent characteristic of all electronics and power supplies, often stemming from sources such as improper grounding, power supply irregularities, or electromagnetic interference from nearby equipment. Noise from electrical sources can be conducted to the DVL or it can be radiated.

Acoustic noise is often created by other acoustic instruments that are operating in a similar frequency to the DVL. In rare cases, acoustic noise can also be generated by vehicle components oscillating.

As noise levels increase, the instrument's ability to distinguish the desired signal from unwanted interference becomes compromised. This can result in inaccurate velocity measurements, reduced range, and unreliable data processing as the noise obscures the true signal and diminishes the instrument's effectiveness. The consequence of noise picked up by the DVL may not be apparent when the DVL is operating at low altitudes over the bottom but as the altitude increases it will reduce the bottom tracking range, and in the case of "colored noise" will bias the velocity estimates, degrading the quality of the navigation.

Common noise sources and solutions

The list of devices that can create noise is extensive. Below are several types of devices that we commonly see causing issues with noise during DVL operation:

- The most common electrical noise problem for a DVL is caused by common mode noise from the power lines. This is often generated in a galvanic isolated power system, which will create an electrical field between the DVL and seawater. The best way to mitigate this is to have a good electrical connection between the negative power input to the DVL and seawater. This can be done in several ways. On standard production units, the DVL will be grounded through the housing when exposed to seawater.
 - Deep water variants achieve this through contact with seawater at any point on the titanium housing.

- On shallow water versions, it's achieved through the grounding plate, typically located near the wet end connectors of the DVL.
- For OEM versions this must be done via the grounding cable on the wiring harness. The cable should be connected to a part of the vehicle's frame that has a good electrical connection to seawater. Because of corrosion issues, this connection is normally made through a capacitor (see Figure 1). In production units, the capacitor is built into the housing's grounding system.

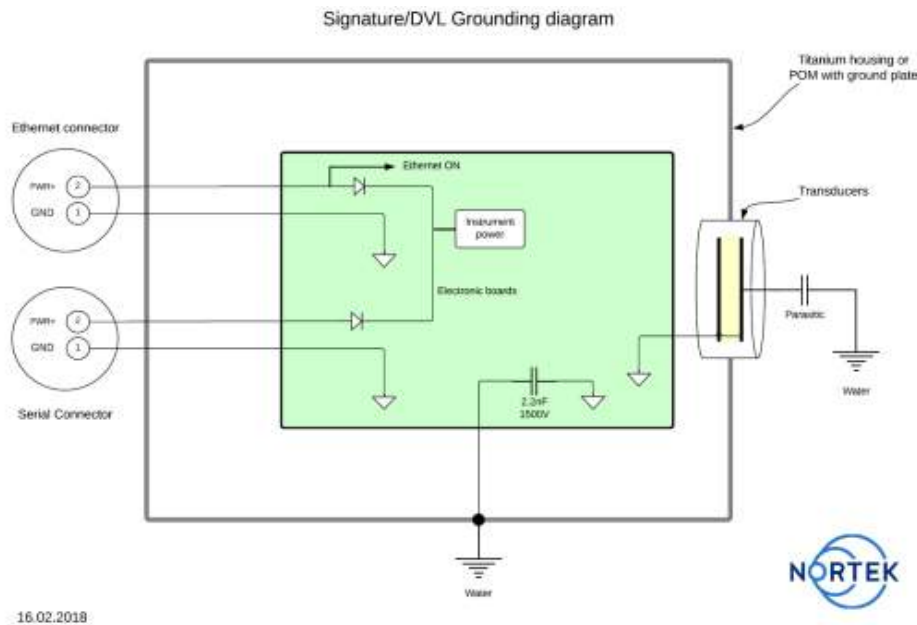

Figure 1: DVL Grounding Diagram

- DC-DC converters are a common source of noise. The switching frequency of the converter can be very detrimental if it is within the operational frequency of the DVL (see table 1 in the 'Tools to identify sources' section). A DC-DC converter that features a switching frequency outside the DVL's operational frequency is key to enabling a low noise platform.
- Power lines must be kept clear of the DVL and placed in areas that will minimize the exposure of noise to the DVL. An example of increasing the risk of noise exposure is when power cables for thrusters (or other sources drawing large currents) are routed close to the DVL. The DVL's sensor head (i.e. transducers) are the most sensitive to electrical noise.
- Other acoustic sensors can have a detrimental effect on DVL performance if they are operating in a similar frequency band as the DVL. This can be identified by checking specifications of different devices before installing or by following the spectrum analysis steps below. If using devices with a different frequency is not possible, the interference can be mitigated by utilizing a trigger to ensure the acoustic signals are offset and do not interfere with each other.

Testing environment

During testing, the vehicle should ideally be submerged in saltwater in an open environment free of noise sources. This, however, may not be practical and so an inside location may have to be used. If an inside location is used, then it is necessary to submerge the DVL in saltwater to allow for proper grounding

(freshwater is often not sufficient). As an example of the benefit of saltwater, adding 0.5 kg of salt to 350 liters of water has shown to reduce noise levels by 10dB. Note that if the tank is isolated from earth (e.g. plastic), then a ground path needs to be included. Depth of submergence is not important. The testing platform should not be exposed to electronic noise sources. This means that testing indoors requires ensuring that noise sources from lights, motors, etc. are minimized. It may be necessary and easier to control the noise by employing a simple Faraday Cage to isolate from electromagnetic disturbances. Ensuring low noise levels in the testing environment will help make testing easier when trying to identify noise sources.

Measuring baseline noise level

The purpose of this is to quantify baseline noise levels with the goal of ensuring the DVL reaches the desired noise floor. This test may also provide the opportunity to evaluate if there are any signs of periodic signals present during the bottom tracking ping's travel time. The test involves enabling the current profile feature with the transmit power turned off. This allows for one to place the instrument in receive mode only and collect data describing the received amplitude and measured correlation. This is particularly useful when one wants to see the result of a particular action, such as enabling a thruster or another acoustic system.

The DVL should be connected to its intended power supply, and if the DVL is an OEM or custom integration, is grounded as prescribed. Either serial or Ethernet may be used during this process. Ethernet permits real time monitoring and display of data, while a serial interface limits the testing to logging to the DVL's recorder. The instrument should be configured so that the current profile extends to the instrument's maximum range. The cell size may be between 0.5 meters and 2 meters, where the difference is the spatial resolution. The blanking distance should be set to its minimum. This allows for any transmitted pulse to die out and the noise floor to become apparent. MIDAS software may be used to configure the Nortek instrument. The amplitude from the current profiles may be viewed in real time with MIDAS software. MIDAS software can be downloaded from the DVL's Web Browser Interface under the applications tab. Please contact Nortek if the Web Browser Interface is unavailable and we will provide the latest version of MIDAS.

Setup

A noise free environment is critical to a successful test. Details of how to create a noise free environment can be found above in the Testing environment section above. It is also critical to keep a detailed timestamped log (excel file is recommended) of all events while collecting data. This will allow for an effective analysis of the data to identify noise in vehicle systems. Note: please ensure DVL firmware is up to date. Contact Nortek for new firmware if required.

1. Connect DVL via Ethernet and apply power to break out cable.
2. Open MIDAS.
3. Connect to instrument via Communication -> Connect -> Network Discover. Network Parameters will then come up. The address box should be highlighted in green. Click apply to connect. The software will likely ask if you would like to put the instrument into command mode which should be accepted.

This will allow you to find the DVL on your network and access it via Ethernet. Operating MIDAS with a serial connection is not an option because of the large bandwidth that the Spectrum Analyzer requires in the subsequent steps. If you are limited to a serial connection, then you will have to configure the instrument and record to the internal DVL memory. The process for this is described further down in this document.



Figure 2: Midas Communication Setup



Figure 3: Midas Network Setup

4. Select button for Instrument Configuration.

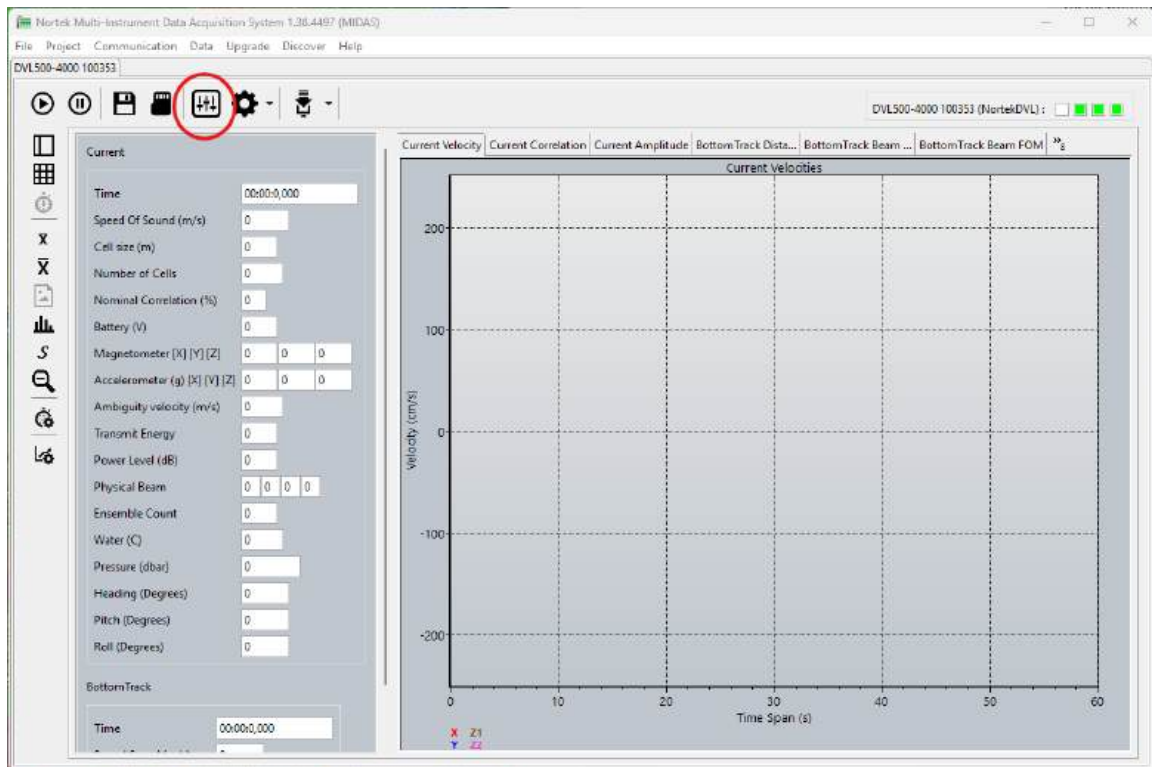

Figure 4: Midas Instrument Configuration

5. Configure the instrument measurements (bottom track) with the settings illustrated in figure 5. Bottom track is always enabled for the DVL but note that the transducers are turned off when power level is set to -100dB. It is critical that the transducers are turned off so the DVL will be in listening mode.
6. Configure the current profiling with the settings shown in figure 6. Current profiling will alternate with the bottom track when the interleave ratio is set to 2.

DVL500-4000 100353 Configuration

Measurement Configuration | Current Profiling | Instrument Settings | Spectrum | Altimeter | File Parameters

DVL Configuration

Trigger Mode: INTSR

Operating Mode: NORMAL

Sampling Rate (Hz): 1

Speed of Sound (m/s): Measured Fixed 1500

Salinity (ppt): 35

Bottom Track

Blanking (m): 0,02 (0.02 - 10.0)

Range (m): 220 (2.0 - 220.0)

Velocity Range (m/s): 5 (5.0 - 5.0)

Transmit Power (dB): USER -100 (-20.0 - 0.0)

Bottom Track Data: DF21 DVL BT Binary

Enable Water Track:

Water Track Data: DF22 DVL WT Binary

Apply Revert

OK Cancel

Figure 5: Midas Measurement Configuration

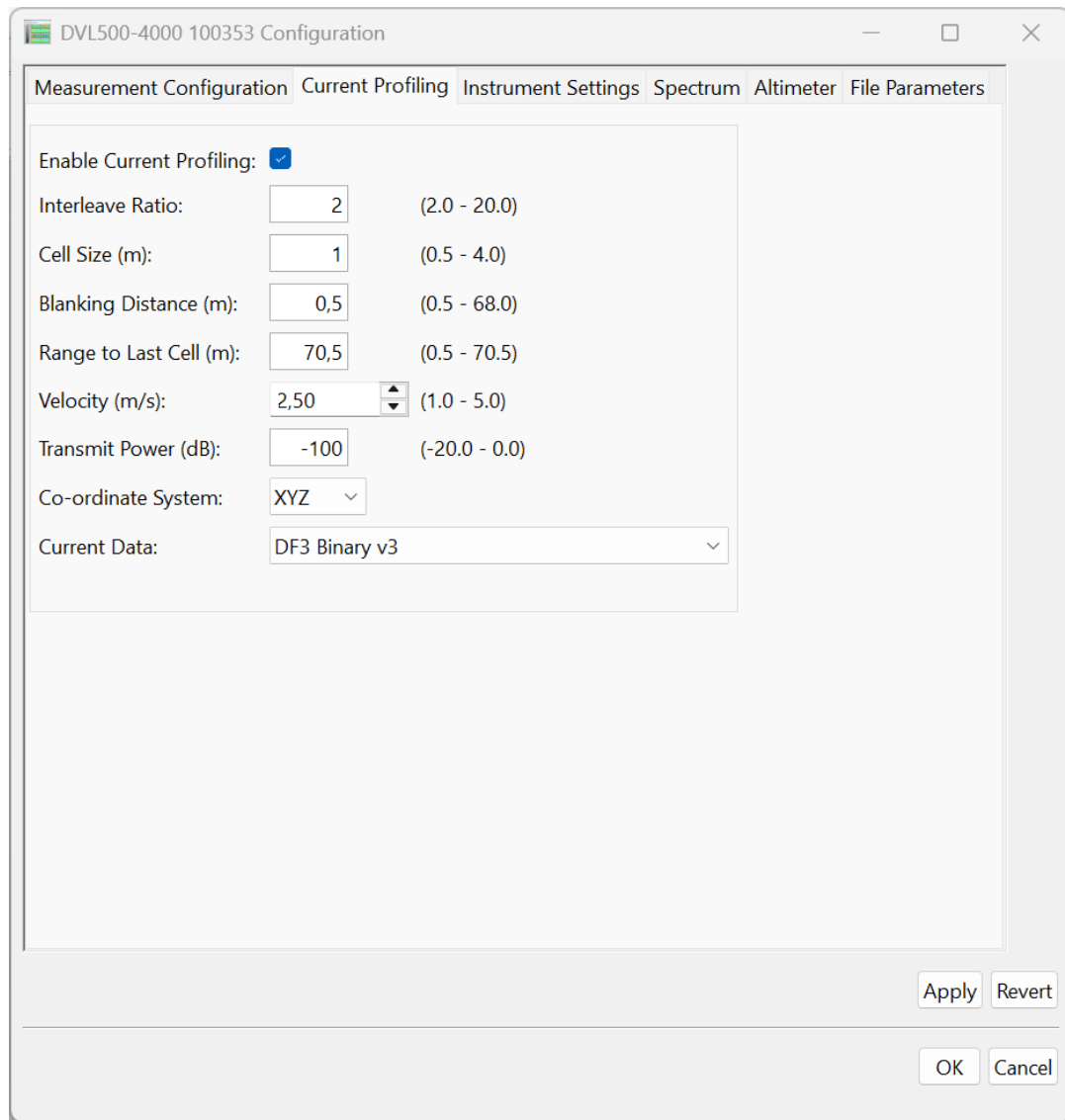

Figure 6: Midas Current Profiling Configuration

7. Configure recording for the DVL, specifying a file name in the "File Parameters" tab. Click OK to save configuration and file name. Select the floppy disk drive on the homepage (see figure 8) to enable saving to computer.

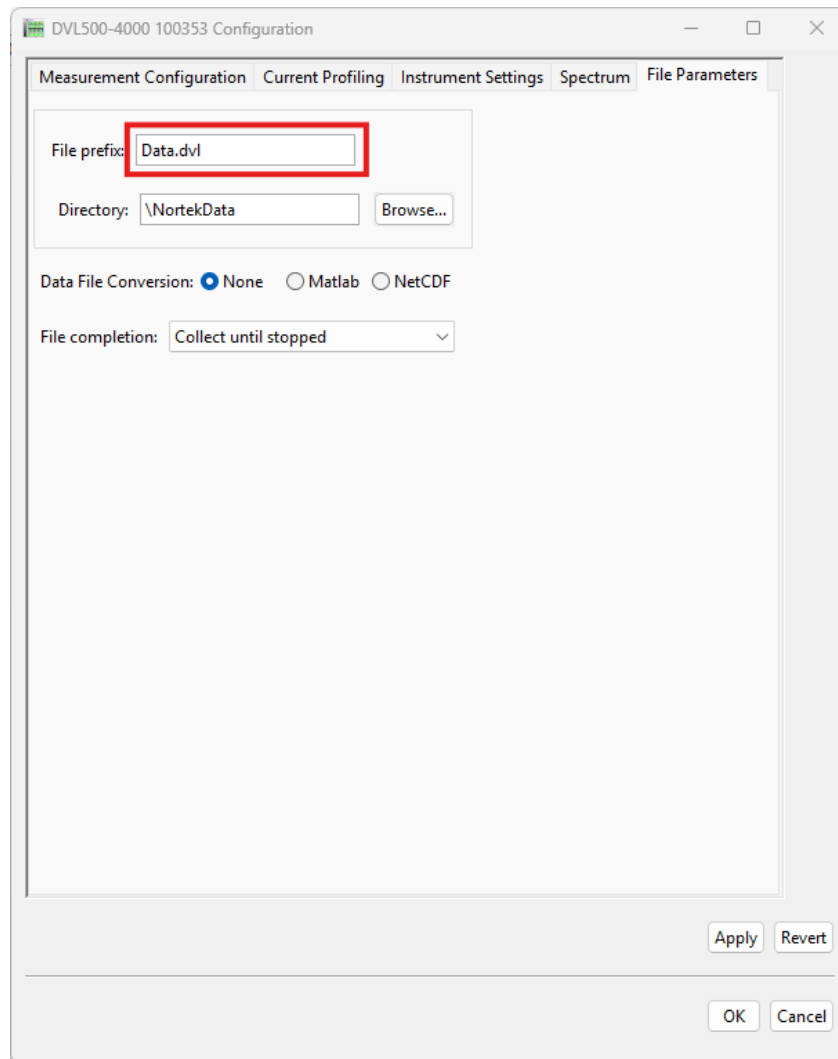

Figure 7: Midas File Parameters

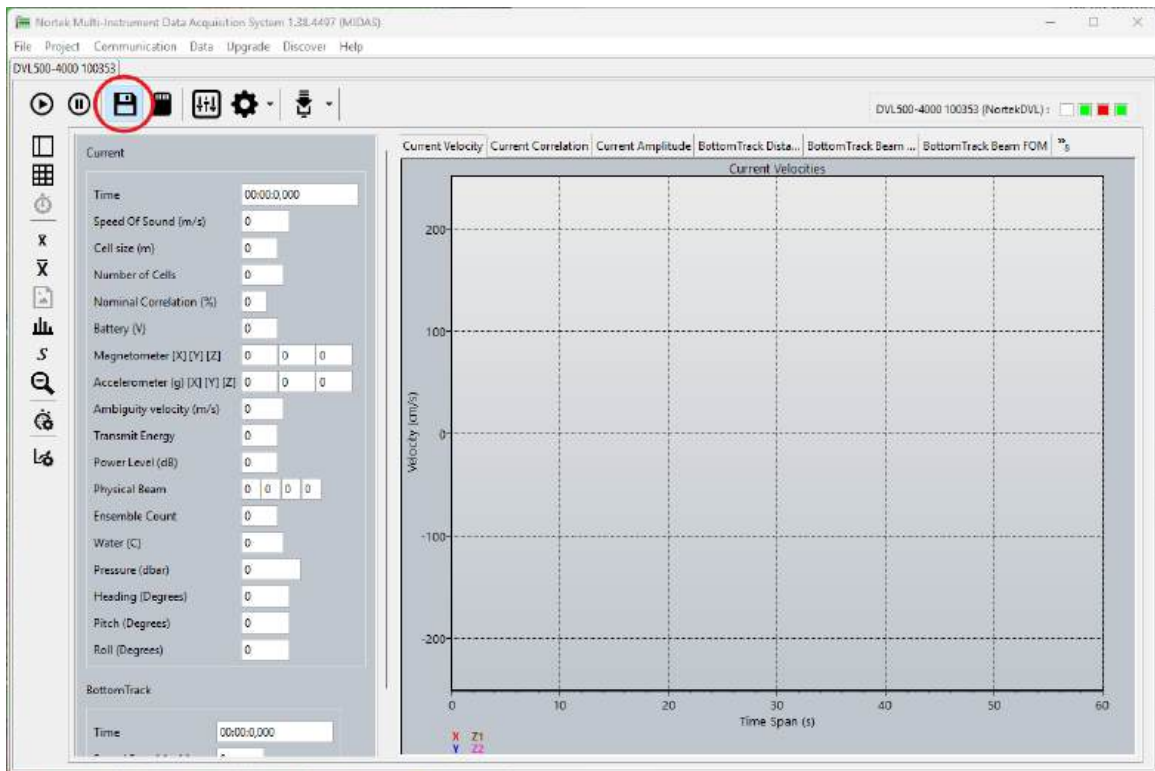

Figure 8: Midas Save to File

8. Alternatively, one may configure recording the spectrum to file on the DVL's recorder. Naturally the recording option is more sensible if there is not a suitable, real-time, communication channel and the DVL/Vehicle is below the surface. This is done by selecting the SD card icon on the Midas home screen (figure 9).

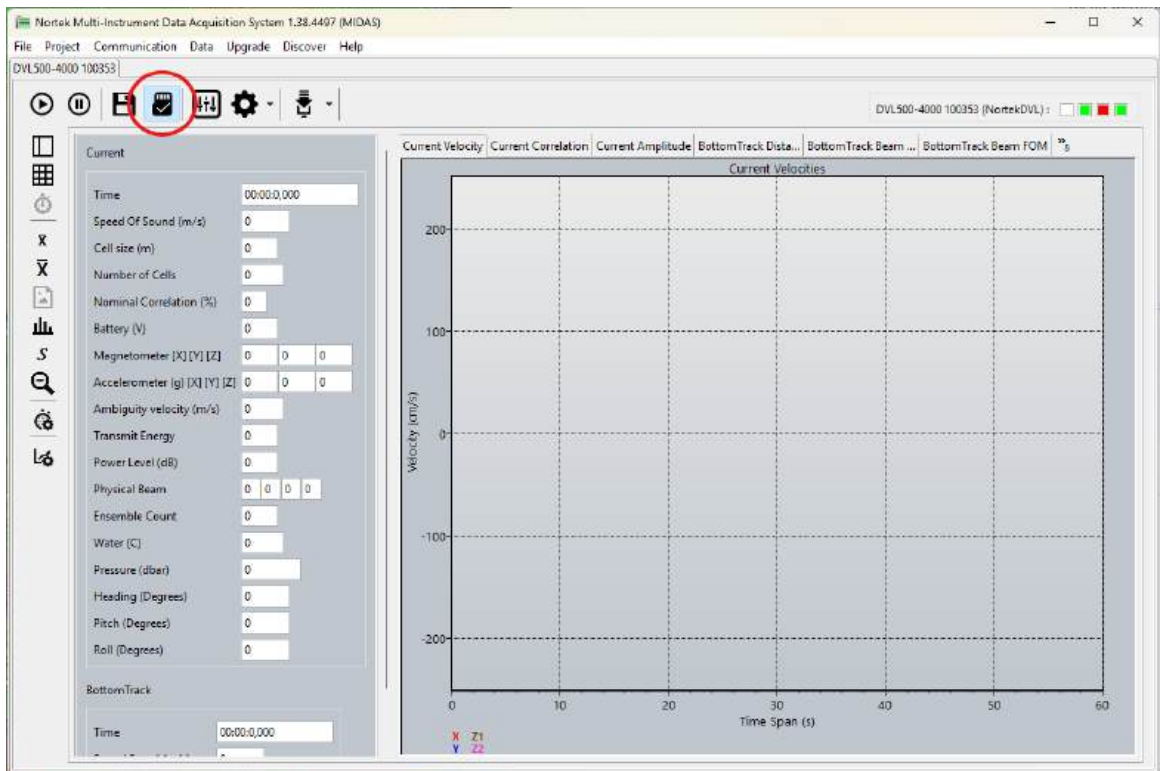

Figure 9: Midas Save to Internal Recorder

Note: Everything in the vehicle should be powered off except for the DVL and power supply. The DVL should be powered by the power supply that is intended for use during the mission.

Conducting base level noise test

1. When ready, click the play button to start the instrument. Note: Do not forget to start the external timestamped log to record events while testing.
2. With only the DVL powered on and the vehicle submerged in a noise free saltwater environment, the noise floor should be below 30dB, falling ideally between 23-26dB. Select 'Current Amplitude' tab (Figure 10) to view real time data. It's also possible to view data after testing. Please contact Nortek for software and assistance in processing recorded data.



Figure 10: Midas Starting and Current Amplitude

If noise floor is below 30 dB, move on to step 6. If noise floor is above 30dB, some further checks will need to be made.

3. A noise free environment is key for a successful test. Ensure that all guidelines in the “Testing environment” section are fulfilled and all vehicle systems are powered off.
4. Check “Common noise sources and solutions” section above to troubleshoot common sources.
5. Perform necessary modifications to vehicle. If no noise sources can be identified, contact Nortek support for further advice.

Now that an acceptable baseline noise floor has been verified, testing can begin to see how other vehicle systems interact with the DVL.

6. Systematically turn on one vehicle system at a time (other acoustic device, thruster, manipulator, etc.) while monitoring the noise level output from the DVL. Record the time and results in the log. Turn off each system before moving to the next one.
7. When a system impacts the baseline noise level of the DVL, make a note in the log. The frequency of the system will be investigated further in the spectrum analysis section below.
8. If all systems have been tested with no impact on the noise floor, the vehicle is considered to have low noise generation and no further testing is required. If systems were found to impact the baseline noise levels, continue testing with the following sections.

Tools to identify sources

Spectrum analysis is a valuable diagnostic tool for assessing the performance of a DVL by providing a visual representation of its bandwidth and any electrical noise affecting its operation. By plotting the frequency components of the signal, the analysis can highlight noise as distinct spikes in the data. These spikes are particularly problematic when they fall within the instrument's operational frequency band, as they can interfere with signal detection and reduce measurement accuracy. The operational frequency bandwidth refers to the frequency band within which an instrument operates effectively. Operational frequency is typically +/- 12.5% of the stated DVL frequency.

DVL Frequency (kHz)	Operational Frequency Bandwidth (kHz)
333	290 - 375
500	435 - 565
1000	875 - 1125

Table 1: DVL Operational Frequency

Spectrum Data Configuration

In order to configure and use the spectrum analyzer tool you will need to have MIDAS installed on your PC and connected to the DVL via Ethernet. This is the recommended way to configure this function and view the data. Operating MIDAS while viewing spectrum analyzer with a serial connection is not an option because of the amount of data transmitted. If you are limited to a serial connection, then you will have to configure the spectrum analyzer and record to the internal DVL memory. The process for this is described further in the later sections.

Setup

1. Open MIDAS.
2. Connect to instrument, Communication -> Connect -> Network Discover (see 'Baseline noise testing setup' section for details)
3. Open the configuration menu and set 'Measurement Configuration' tab with values shown in Figure 12. Note: Settings displayed below are for a 500kHz DVL. Other types of DVLs should be set with a similar value with respect to the DVL's performance.

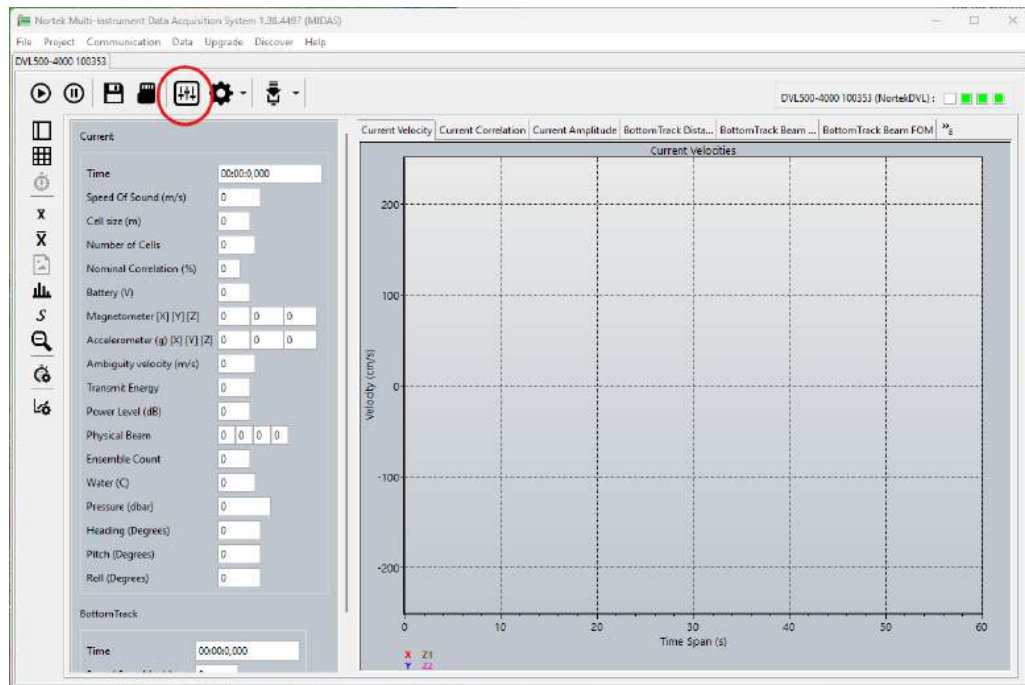

Figure 11: Midas Configuration Tab

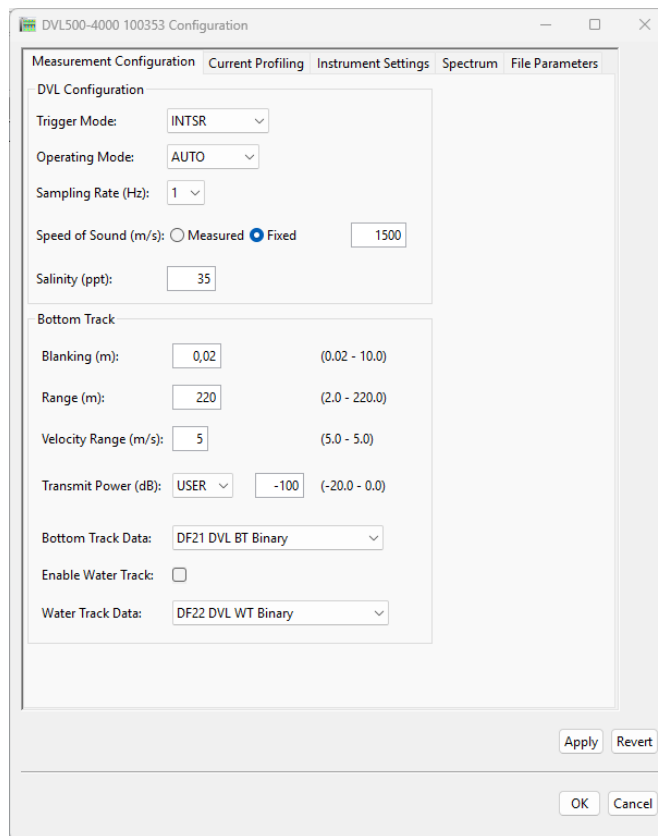

Figure 12: Midas Measurement Configuration

4. Select tab for "Spectrum".
5. Configure the spectrum analyzer and apply settings shown in Figure 13.

Note: 199 data cannot be used in combination with the spectrum analyzer (see figure 14 for error message). Contact Nortek if assistance is needed to disable 199 data.

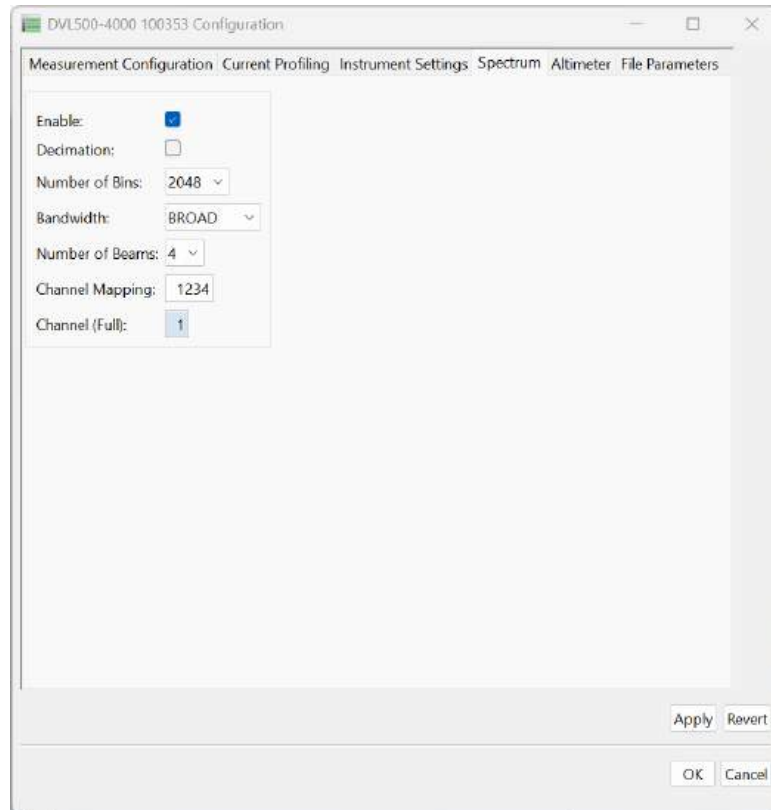

Figure 13: Midas Spectrum Tab

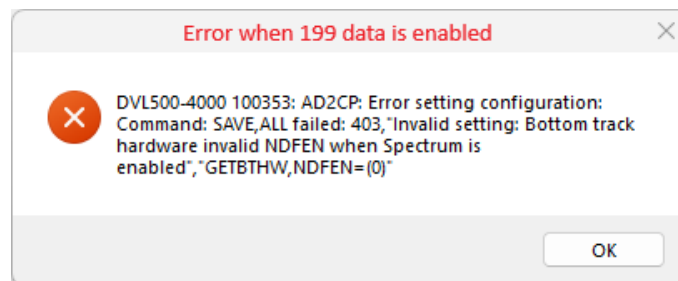

Figure 14: Midas 199 Data Error

6. Configure recording for the DVL, specifying a file name in the "File Parameters" tab (figure 15). Click OK to save configuration and file name. Select the floppy disk drive on the homepage to enable saving to computer (figure 16).

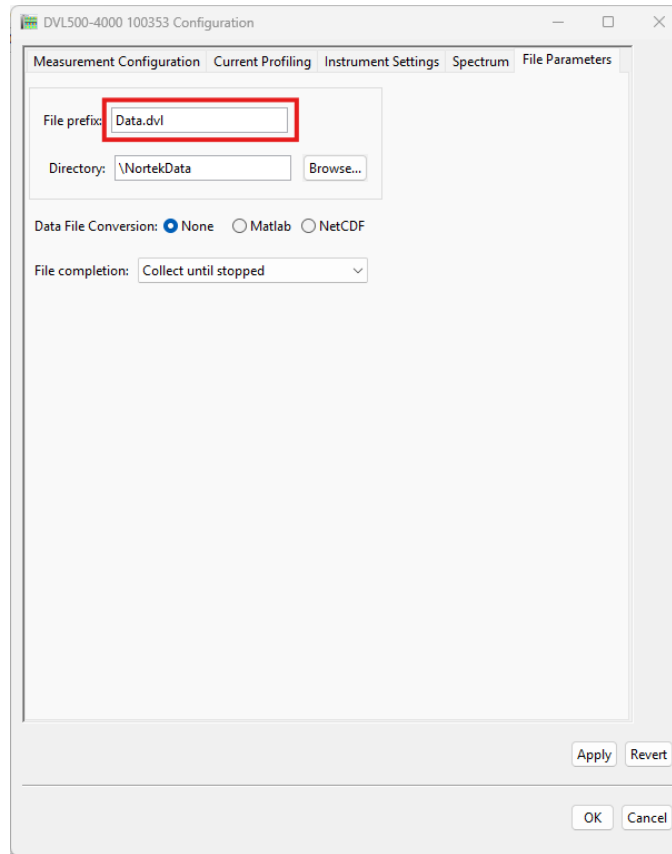

Figure 15: Midas File Configuration

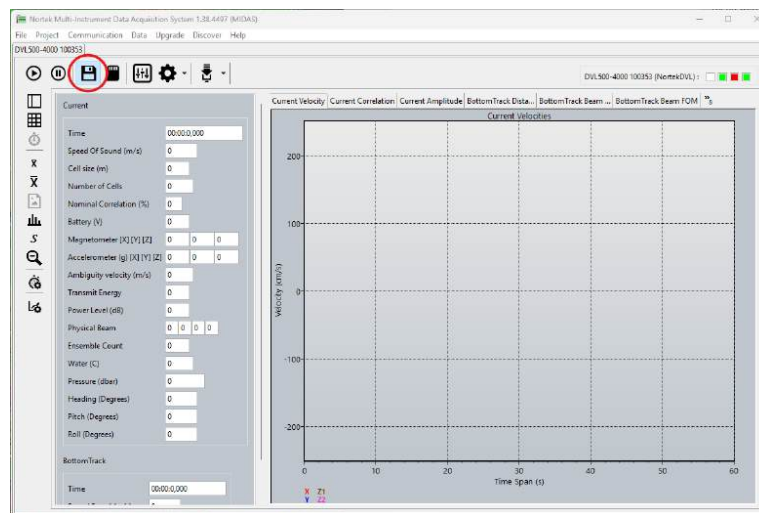

Figure 16: Midas Save to File

- Alternatively, one may configure recording the spectrum to file on the DVL’s recorder. Naturally the recording option is more sensible if there is not a suitable, real-time, communication channel and the DVL/Vehicle is below the surface. This is done by selecting the SD card icon on the Midas home screen (figure 17). Contact Nortek for assistance to view recorded data.

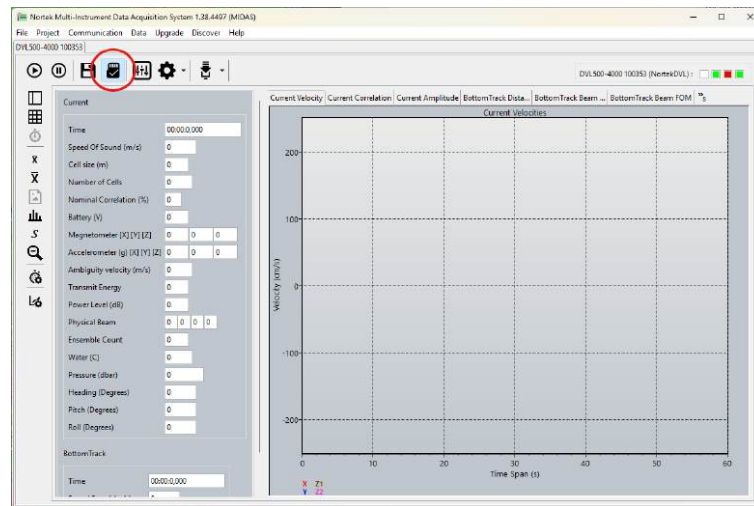

Figure 17: Midas Save to DVL Recorder

8. Submerge the DVL into the testing environment and start the DVL by selecting play button in the top left corner.

Running test and interpretation

1. Begin testing with only the DVL and vehicle power supply powered on. The most important tabs shown on Midas while testing are 'Spectrum' and 'Current Amplitude'.
2. If the 'Frequency vs Amplitude' graph looks similar to the graph in figure 18 and figure 20, proceed with the testing. If the graph looks more similar to the graph in figure 19 and figure 21, return to the "Background noise testing" section to identify and remove sources.

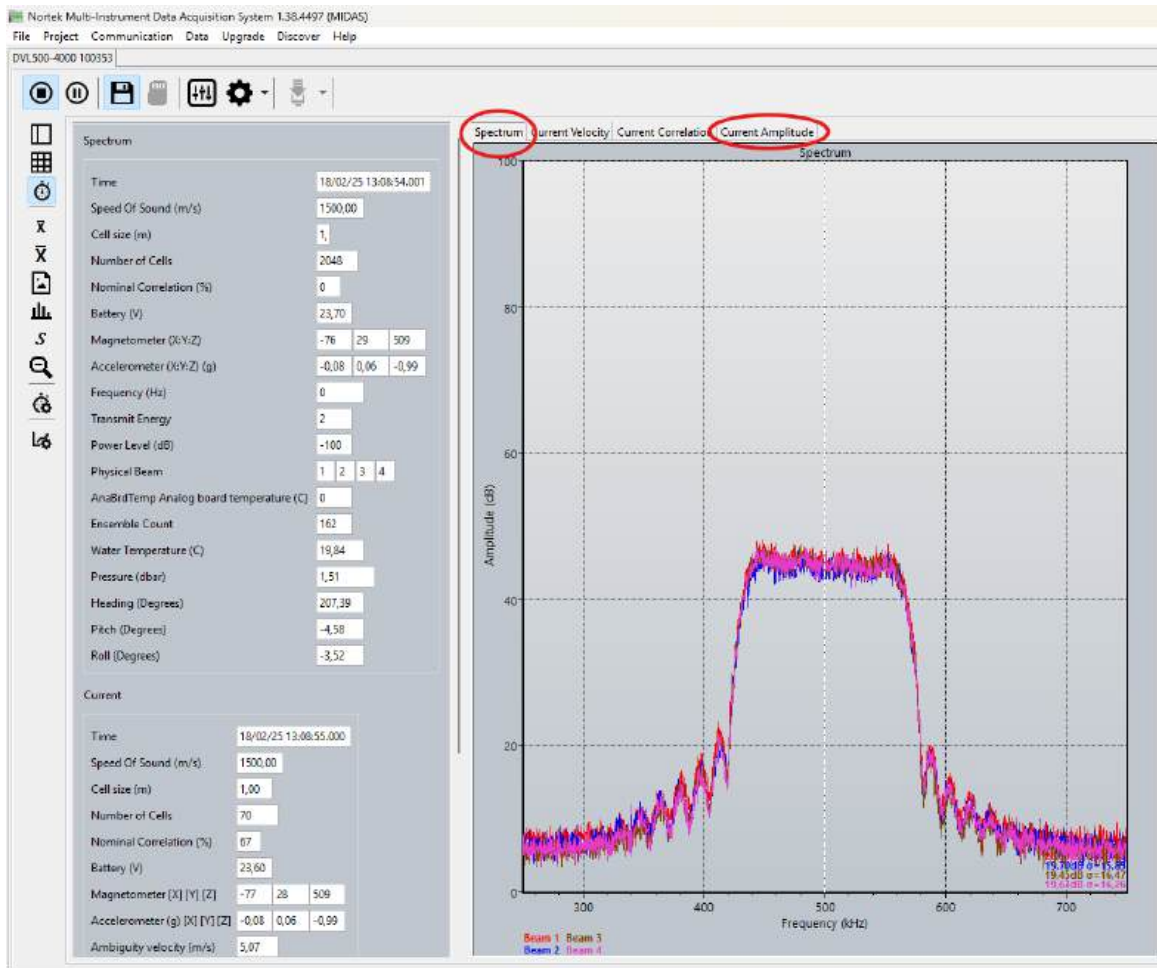

Figure 18: Midas Good Frequency vs Amplitude

Figure 18 is a good example of the 'Spectrum' tab in a low noise environment. Looking at the Amplitude vs Frequency graph, one can see a nice flat bandwidth plateau with a steep rise on both sides. The flatness of the plateau shows there are minimal noise sources within the DVL's bandwidth. The steepness of the sides shows there is low baseline noise in all frequencies near the DVL's operating bands. The 'Amplitude' on the y-axis should be ignored as it is not important, only the shape of the bandwidth should be analyzed.

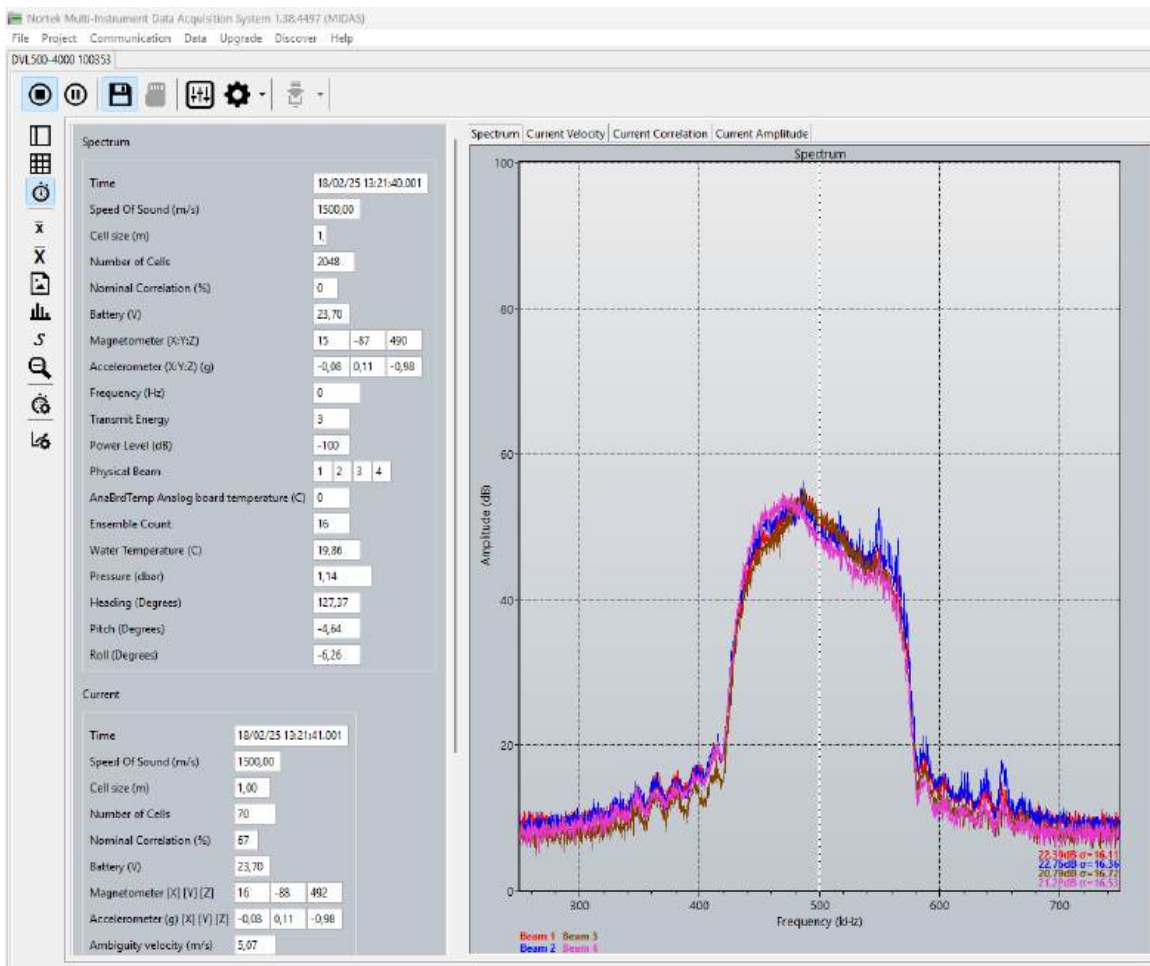

Figure 19: Midas Poor Frequency vs Amplitude

Figure 19 shows a spectrum tab with the DVL in air. This is a noisier reading with small peaks throughout the frequency band. The bandwidth plateau is also worse, with two prominent peaks with a substantial slope in between.

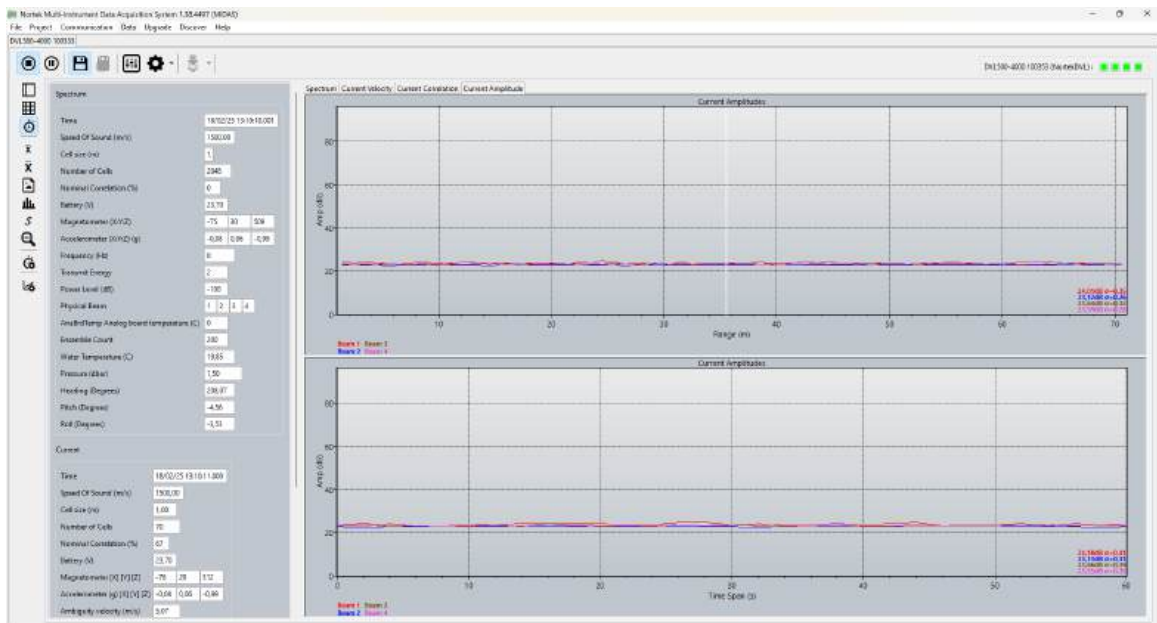

Figure 20: Midas Good Range vs Amplitude

Figure 20 shows the 'Current Amplitude' tab from the same data set as figure 18. The Range vs Amplitude graph quantifies the noise floor, which in this case is shown to be very good at around 25dB.

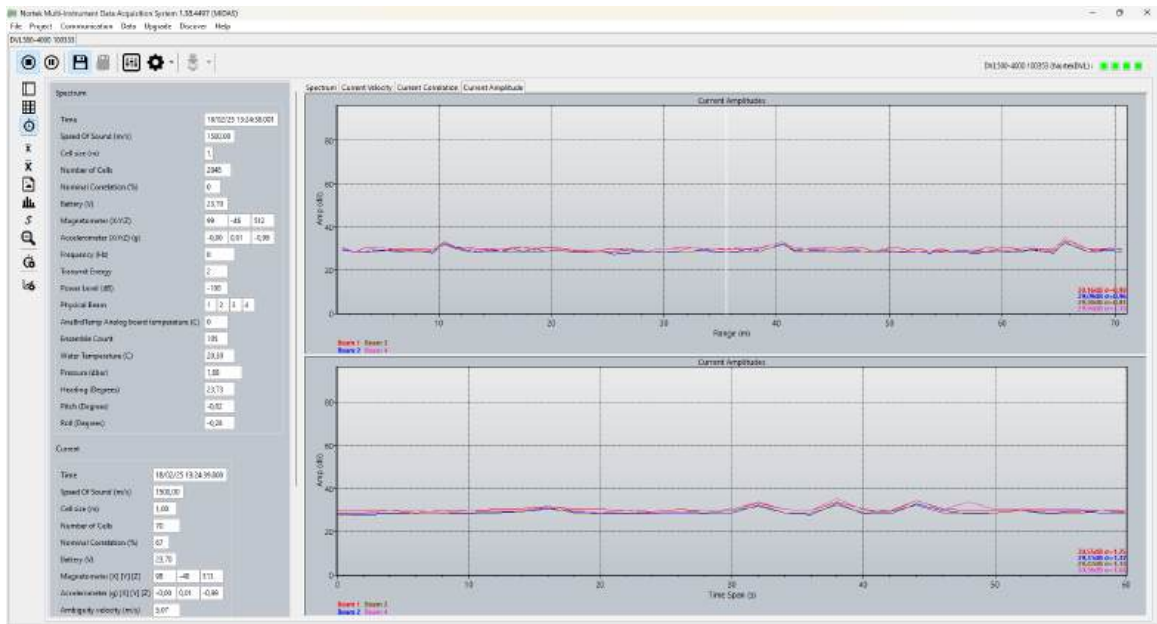

Figure 21: Midas Poor Range vs Amplitude

Figure 21 shows the 'Current Amplitude' tab from the same data set as figure 19. In this graph we can see an elevated noise floor hovering around 30dB. This shows the impact from the deteriorated noise bandwidth plateau as an overall higher noise plateau of roughly 5dB.

3. Turn on one of the systems that was identified to generate noise in the background noise testing. View the 'Frequency vs Amplitude' graph on the 'Spectrum' tab and compare to examples below. *Note: Data shown below comes from various instruments but are applicable for all DVL models.*

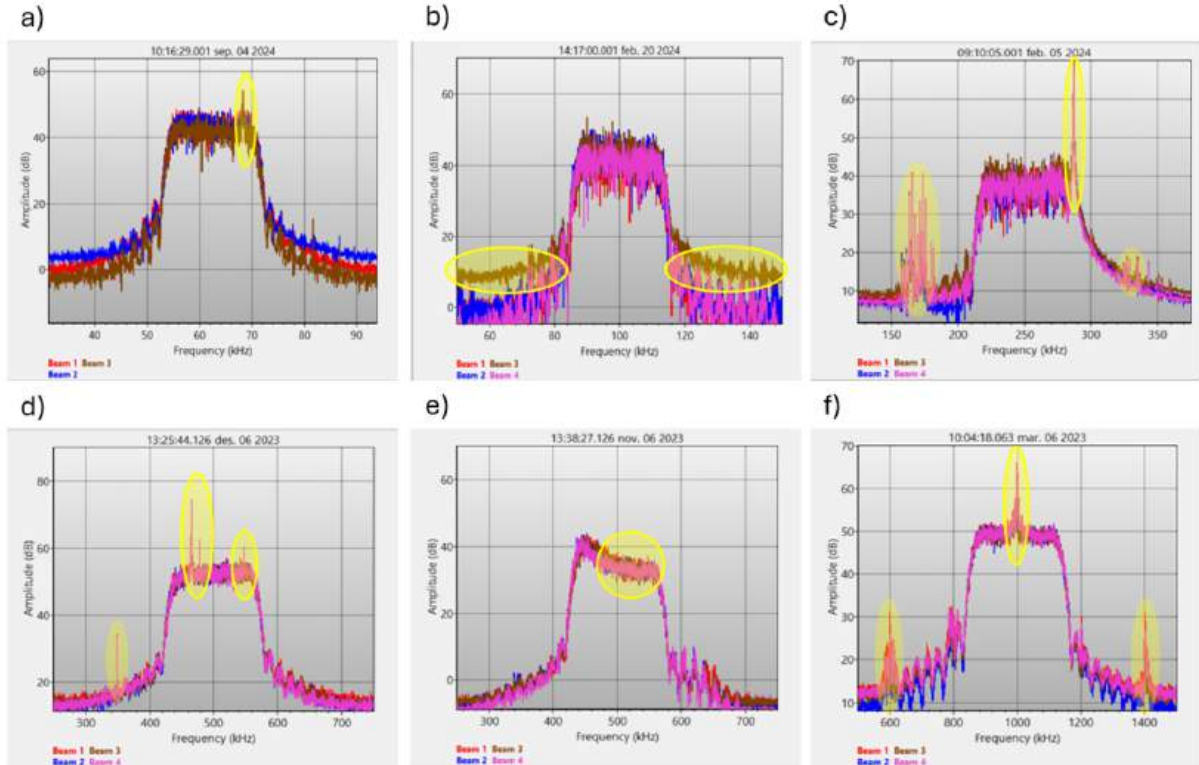

Figure 22: Spectrum Examples

Figure 22 displays a compilation of Nortek Signatures with different frequencies. Multiple types of interference features are highlighted. Yellow circles indicate areas of electrical noise: (a) Frequency peak within the 55 kHz bandwidth; (b) Elevated noise floor in beam 3 of the 100 kHz signature; (c) Multiple peaks across the 250 kHz spectrum; (d) Frequency peak within the 500 kHz bandwidth; (e) Spectrum indicating improper grounding in water; (f) Frequency peak within the 1000 kHz bandwidth.

Adjusting Spectrum Bandwidth

Adjusting the spectrum bandwidth can assist when diagnosing some types of noise found in previous sections. Switching to Ultra or Full allows for analysis of a boarder perspective of frequencies outside the operational band which can help to identify harmonic noise sources. Due to the large data rate, only one channel (beam) can be selected at a time.

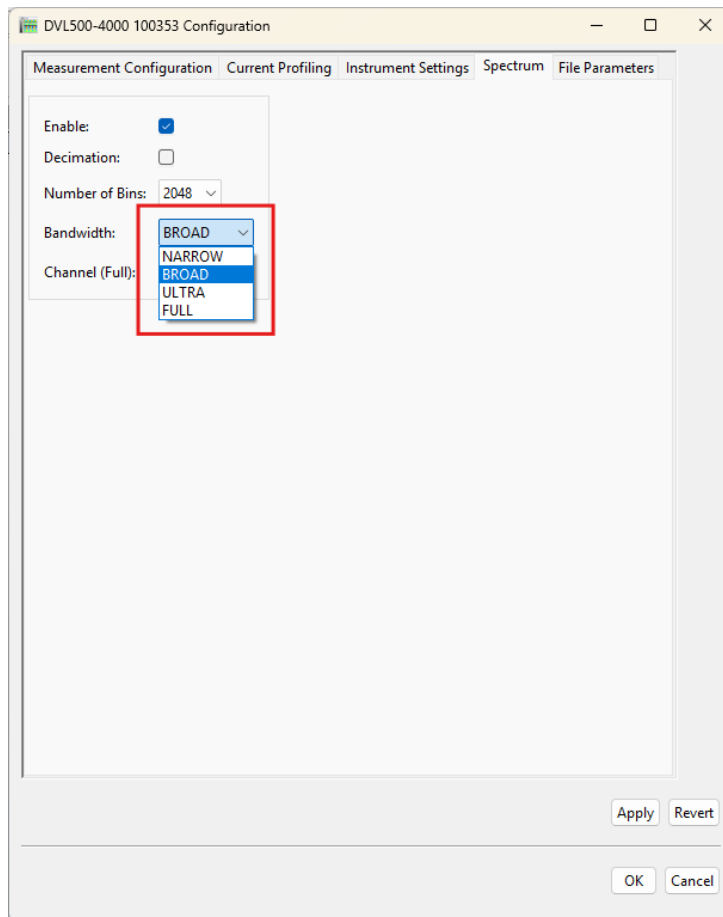

Figure 23: Midas Spectrum Bandwidth

Settings Overview

The following is an overview of the settings (from MIDAS help documentation):

Enable: Turns on the collection of spectrum data. Note that spectrum data replaces bottom track data when enabled (i.e. no bottom track data will be collected).

Decimation: Decimate the raw data before performing the spectrum calculation. The decimated and filtered data is equivalent to the demodulated data after the front end processing.

Number of bins: Number of frequency bins to calculate for the spectrum

Bandwidth: Selects the appropriate frequency range for the spectrum calculation. The FULL bandwidth outputs the spectrum of the raw analog input signal from 0 Hz (DC) to 4 MHz. The other bandwidths output the spectrum of the complex demodulated signal with the center frequency equivalent to the transducer center frequency. The relative filter bandwidths are shown below. Note that due to processing constraints, FULL only allows data from a single beam to be collected.

NARROW: 6.25%

BROAD: 25%

ULTRA: 50%

FULL: 0 – 4 MHz

Number of Beams: Number of beams on which to collect a spectrum when the bandwidth isn't FULL (not applicable to the DVL).

Channel Mapping: The beams to collect a spectrum when the bandwidth isn't FULL (not applicable to the DVL).

Channel (Full): Selects the channel (beam) to use when a bandwidth of Full is chosen.

Command Line Operation

```
SETDEFAULT, ALL
SETDVL, CP=2
SETCURPROF, NC=50, CS=1, BD=0.1, DF=3, PL=-100
SAVE, CONFIG
```

Command line operation of the spectrum analyzer is the option for DVLs operating with a Serial interface. The command follows the structure documented in the [Integrators Interfaces](#) section and is invoked with SETSPECTRUM/GETSPECTRUM. The following is an example of how we explicitly set the spectrum analyzer.

```
SETSPECTRUM, EN=1, BW="BROAD", NFFT=2048, DEC=0, NB=4, CH=1234, CHFULL=1
Or more succinctly:
SETSPECTRUM, 1, "BROAD", 2048, 0, 4, 1234, 1
```

EN is enable spectrum analyzer.

BW is the bandwidth and may be NARROW, BROAD, ULTRA, FULL.

NFFT is the number of bins and may be 512, 1024, 2048.

DEC is enable decimation or not.

NB is the number of beams.

CH is the beam selection, an example of four beam is 1234.

CHFULL is the beam selection for the full spectrum analysis.

Once this command has been issued then a SAVE, ALL command is necessary and then the process may be started with the START command.

Data Export

The data that is collected may be exported to a more user-friendly format such as text or MATLAB. For operators using MIDAS to collect data, they may enable data conversion which is done in real time with the Spectrum Analyzer operation. See MIDAS manual for information on how to enable this feature.

Alternatively, recorded data can be exported to MATLAB by selecting the Data menu item, converting AD2CP to NTK and then exporting to MATLAB or ASCII. Opening this resulting MAT file will provide a "Data" data structure, which contains the relevant information and definitions of the fields.

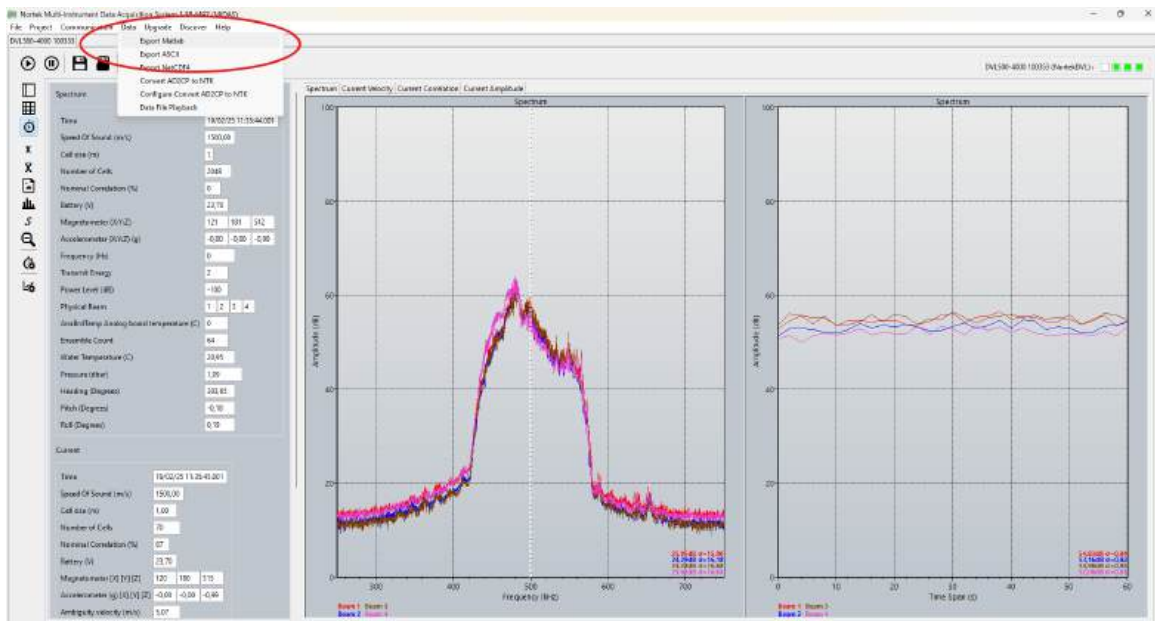
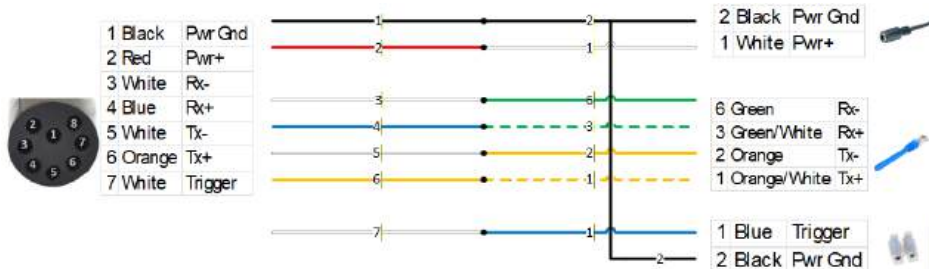

Figure 24: Midas Data Export

15.5 Cable Connector Pin Configurations

In these diagrams, "wet end" means the connector on the instrument side of the cable, while "dry end" means the connector on the computer side of the cable.

8-pin, Ethernet AD2CP Cable with TTL sync (N2550-051)



8-pin, Ethernet AD2CP Cable with RS485 Sync (N2550-052)

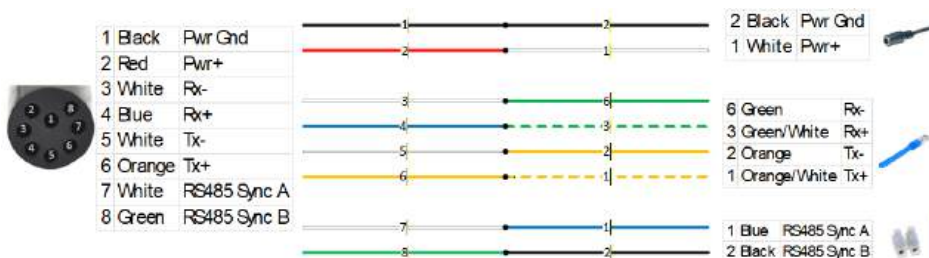

8-pin, Serial AD2CP Cable with TTL sync (N2550-050)

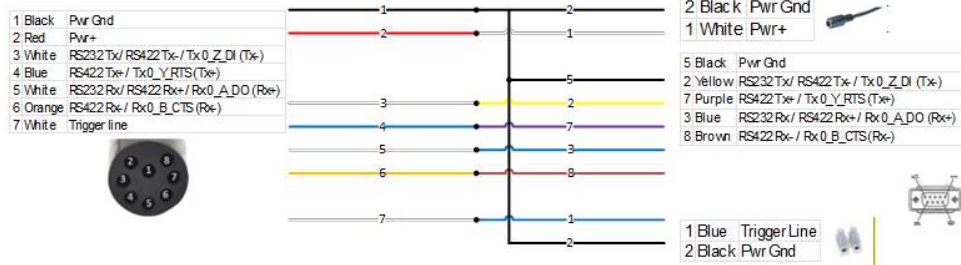

8-pin, Serial AD2CP with RS485 Sync (N2550-053)

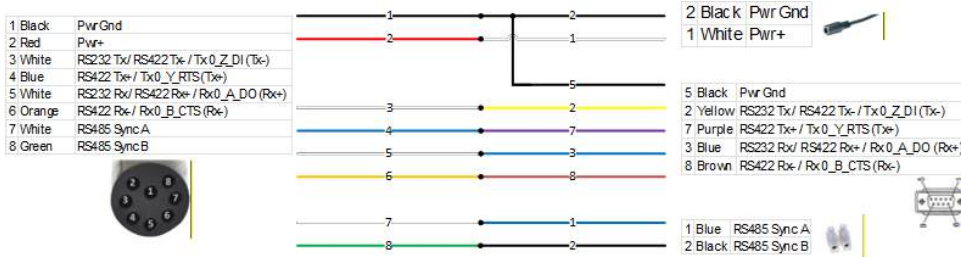

8-pin, AUX SERIAL RS232 AD2CP Pinout with TTL Sync (N2550-081)



Seanet (Schilling) 7-pin, RS232 AD2CP Pinout with TTL sync (N2500-080)

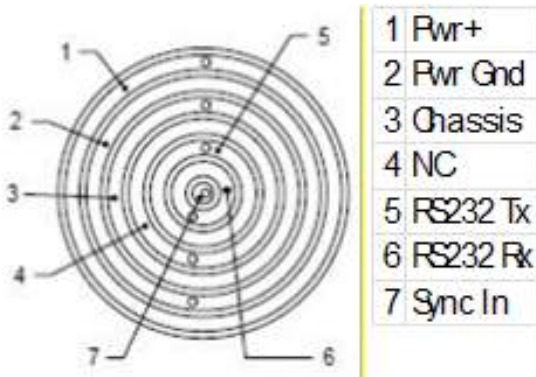

OEM harness, Ethernet AD2CP Cable with TTL Sync (N2550-012)

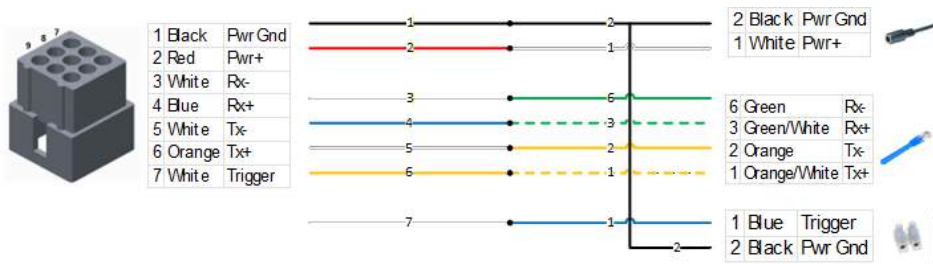

OEM harness, Ethernet AD2CP Cable with RS485 Sync (N2550-059)

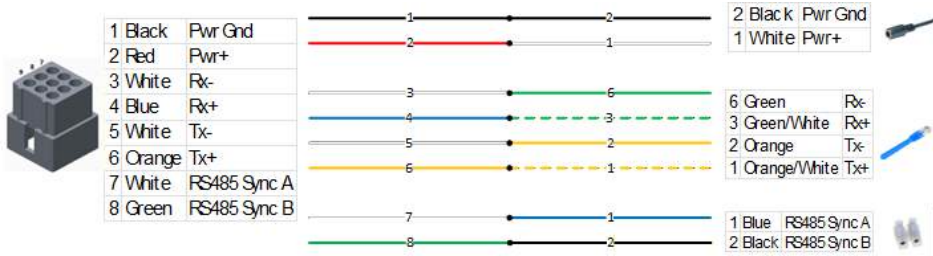

OEM harness, RS232/RS422 AD2CP Cable with TTL Sync (N2550-013)

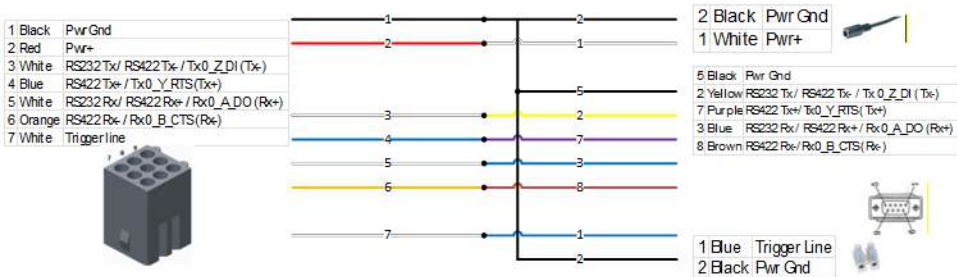

OEM harness, RS232/RS422 AD2CP Cable with RS485 Sync (N2550-060)

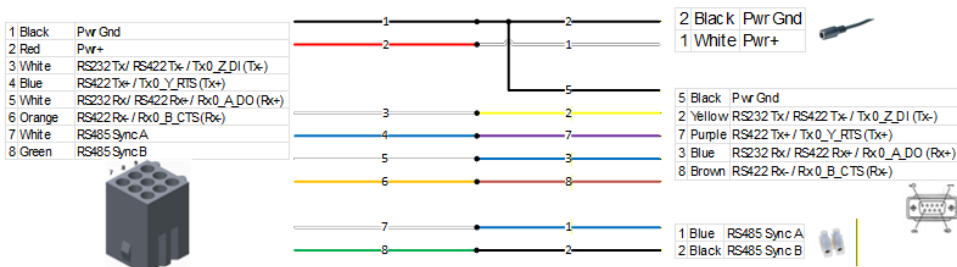

OEM harness, AUX SERIAL RS232 AD2CP Pinout with TTL Sync (N2550-087)



1	Pwr Gnd
2	Pwr+
3	RS232 TX Aux
5	RS232 RX Aux
7	Trigger line

15.6 Mechanical Drawings

DVL Generation 3 Mechanical Drawings

Current drawings as of time of publishing (check links for most recent)

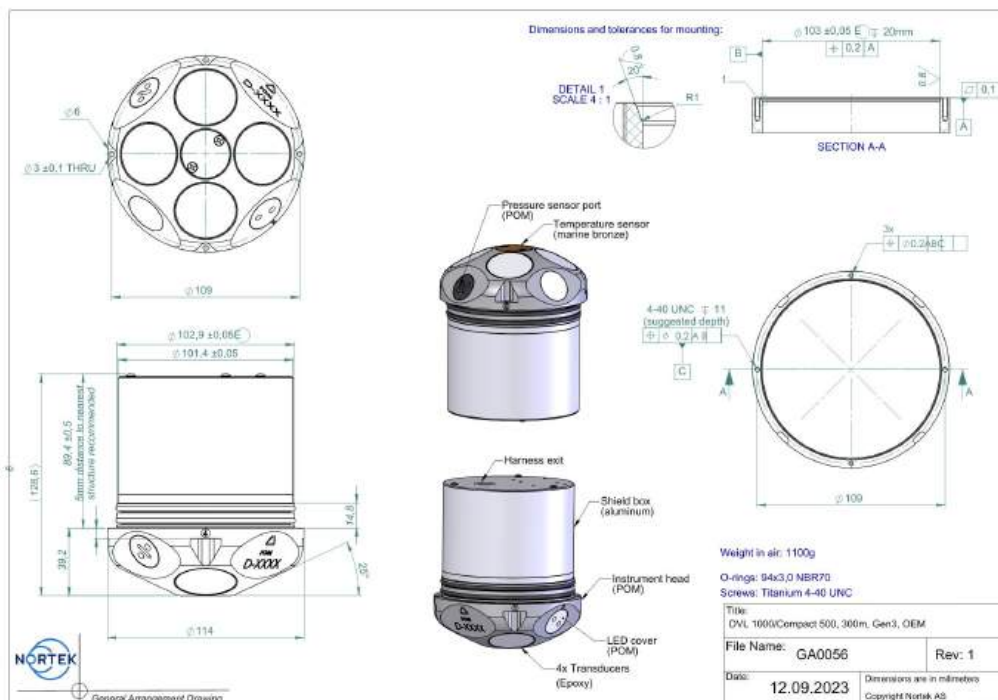
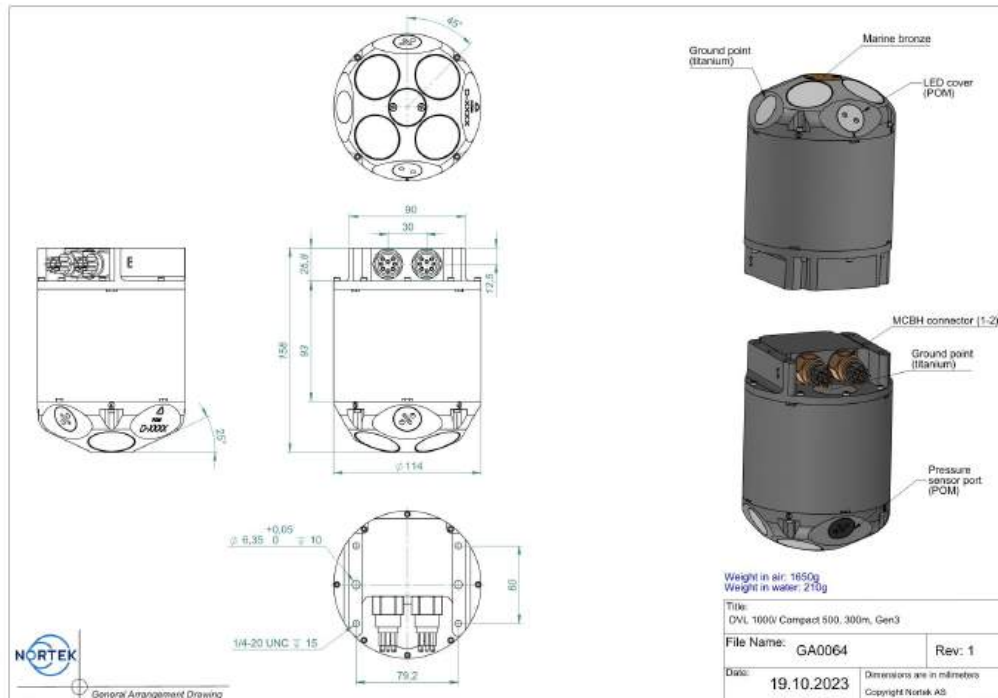

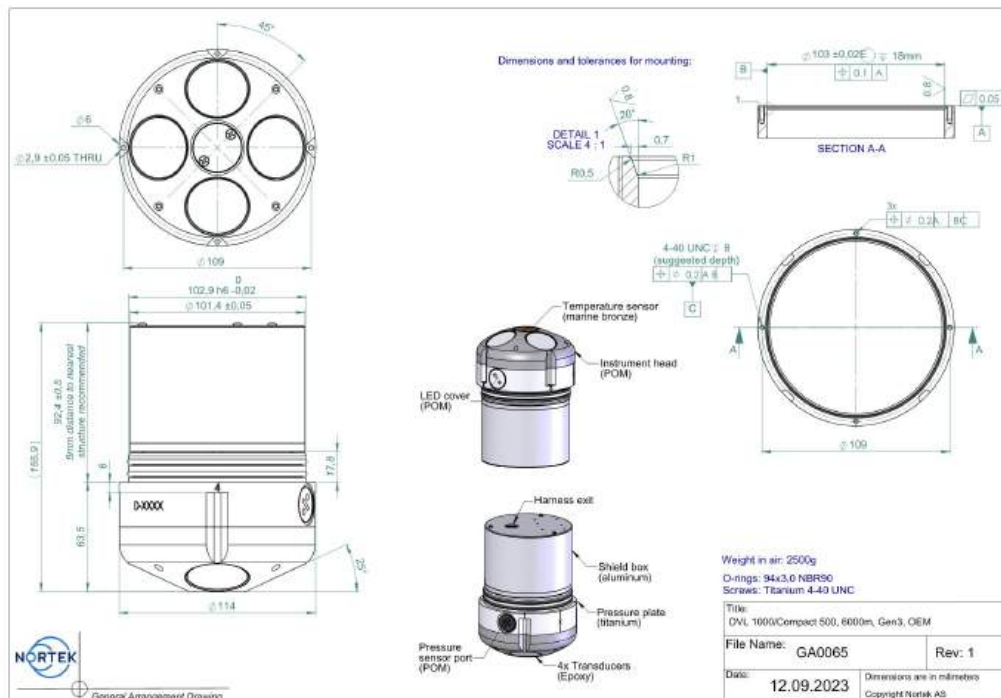
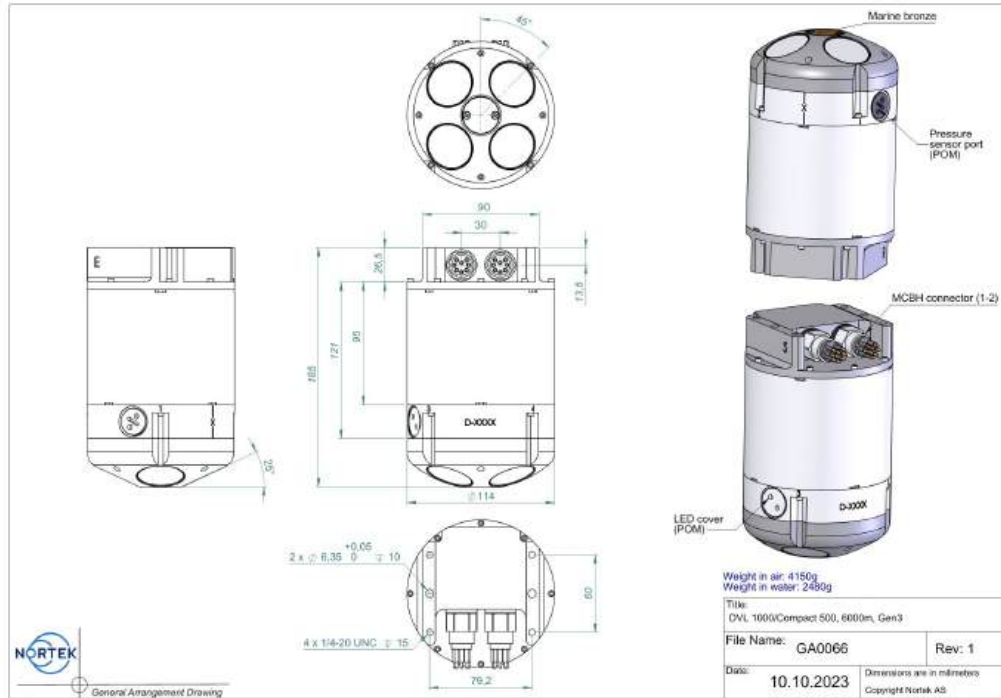

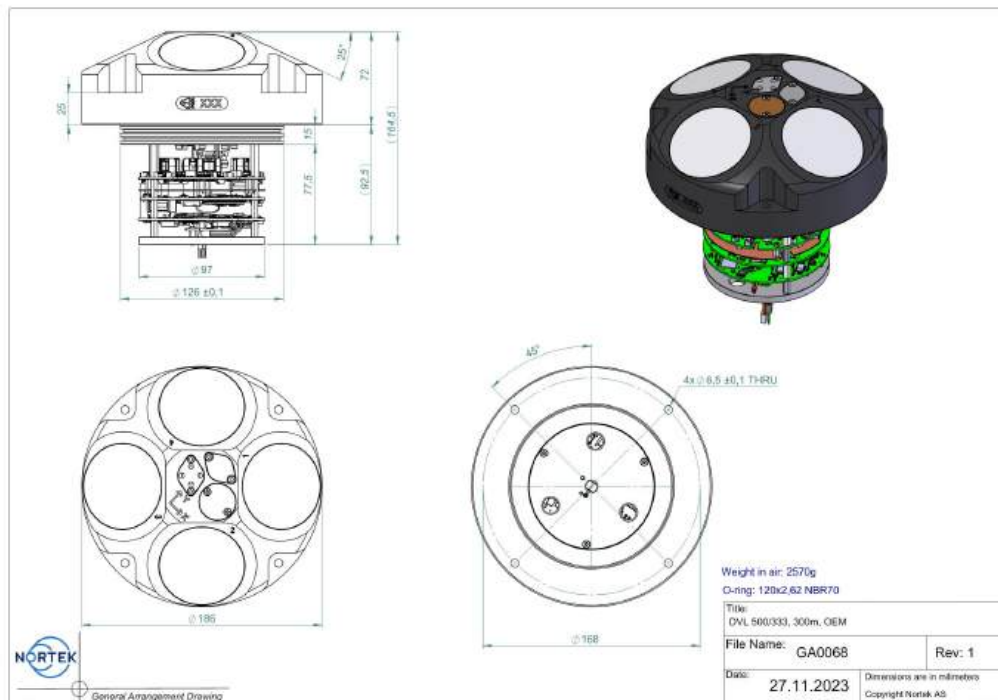
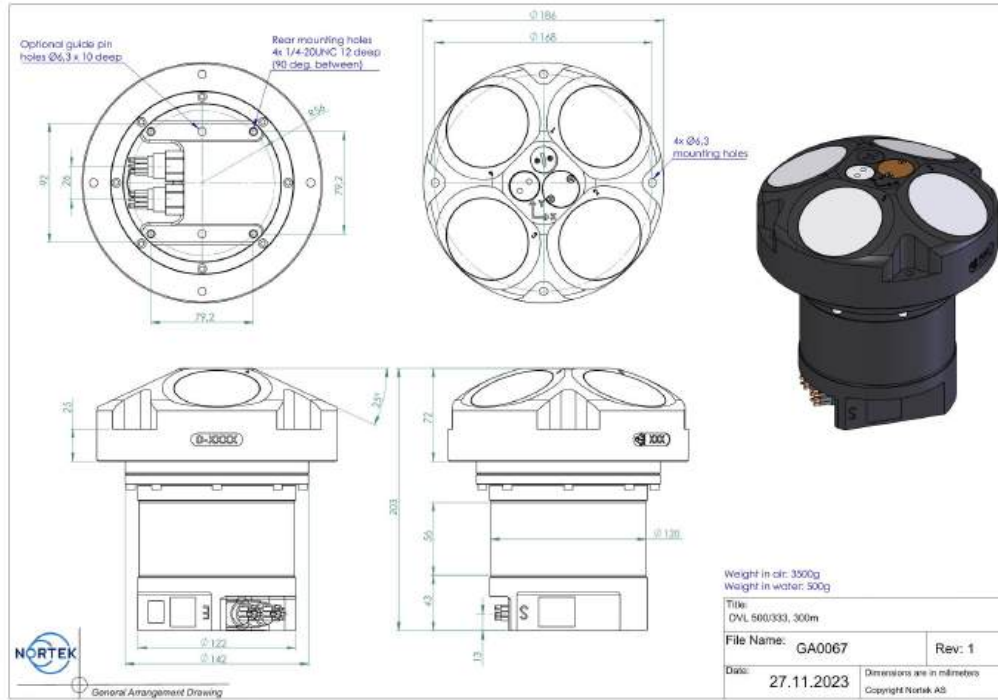

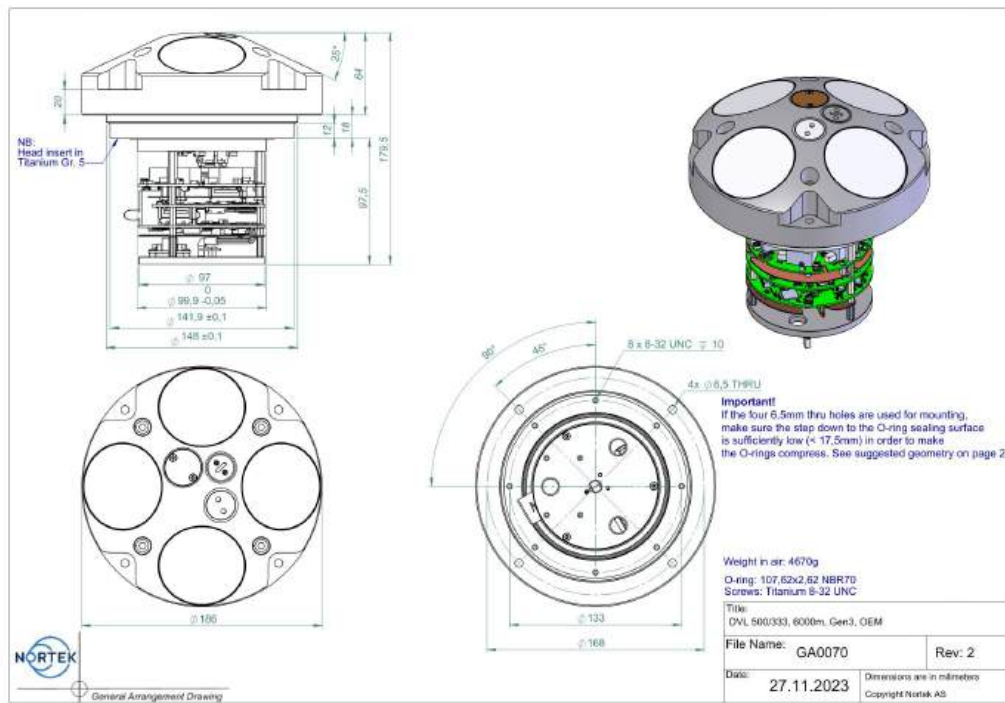
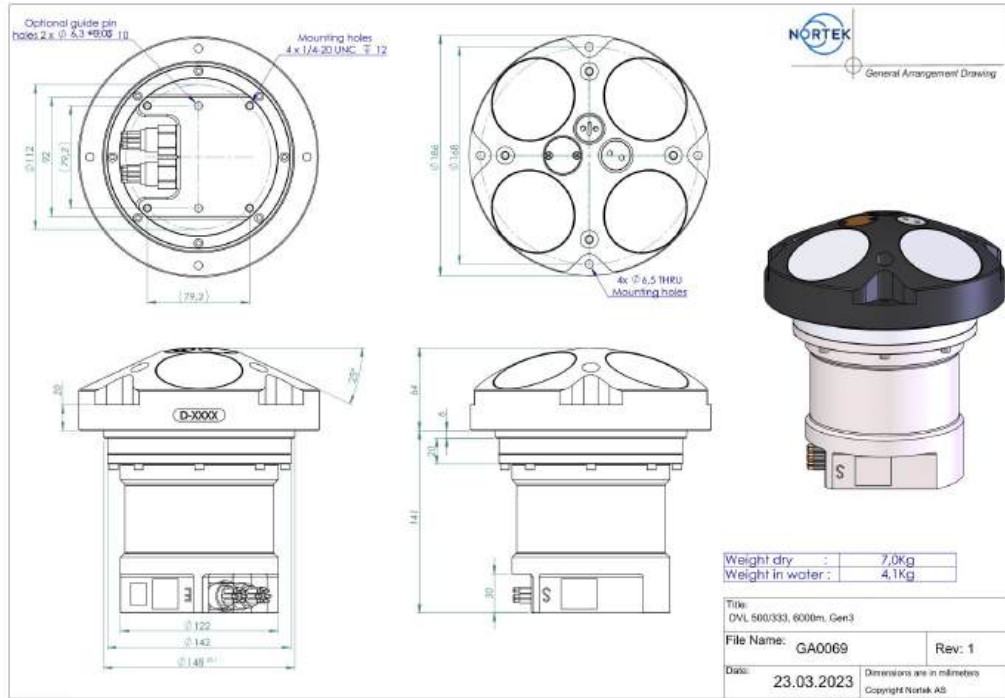

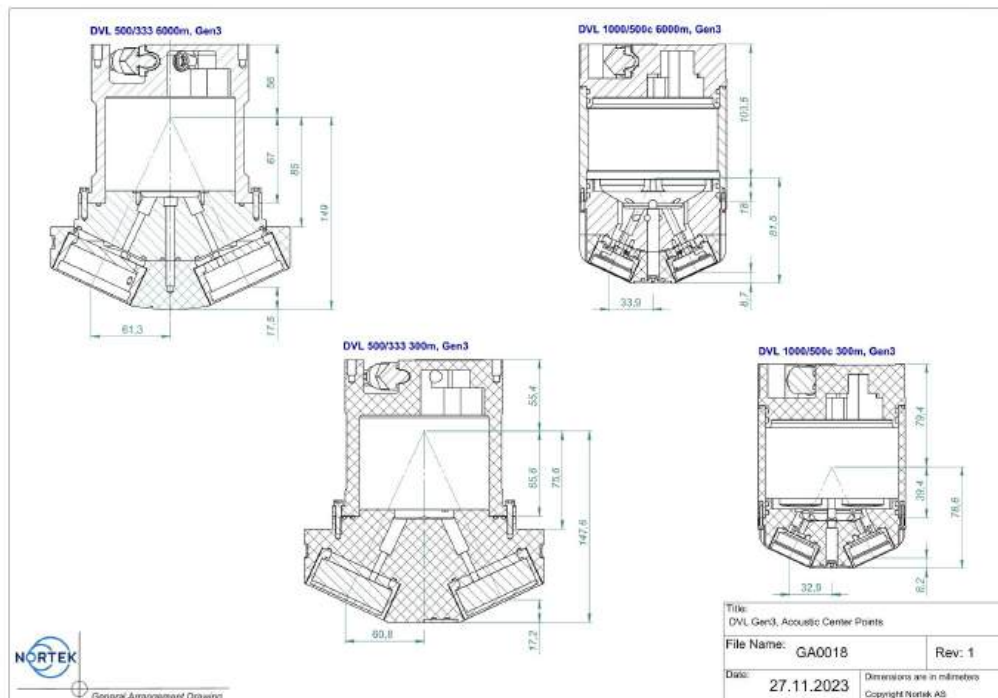
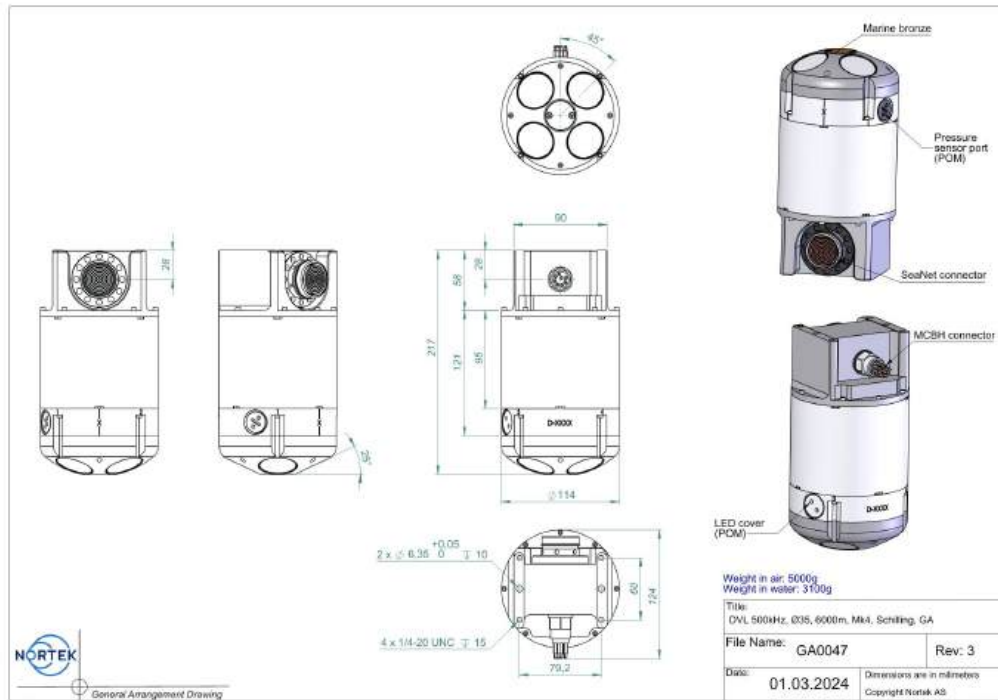

DVL Generation 3 Mechanical Drawings

DVL Compact 500 / 1000, 300m, Gen3	https://nortek.hsapp.cloud/public/ts/view.aspx?t=doc&o=GA0064&open=GA0064*.pdf
DVL Compact 500 / 1000, 300m, Gen3, OEM	https://nortek.hsapp.cloud/public/ts/view.aspx?t=doc&o=GA0056&open=GA0056*.pdf
DVL Compact 500 / 1000, 6000m, Gen3	https://nortek.hsapp.cloud/public/ts/view.aspx?t=doc&o=GA0066&open=GA0066*.pdf
DVL Compact 500 / 1000, 6000m, Gen3, OEM	https://nortek.hsapp.cloud/public/ts/view.aspx?t=doc&o=GA0065&open=GA0065*.pdf
DVL 333 / 500, 300m	https://nortek.hsapp.cloud/public/ts/view.aspx?t=doc&o=GA0067&open=GA0067*.pdf
DVL 333 / 500, 300m, OEM	https://nortek.hsapp.cloud/public/ts/view.aspx?t=doc&o=GA0068&open=GA0068*.pdf
DVL 333 / 500, 6000m, Gen3	https://nortek.hsapp.cloud/public/ts/view.aspx?t=doc&o=GA0069&open=GA0069*.pdf
DVL 333 / 500, 6000m, Gen3, OEM	https://nortek.hsapp.cloud/public/ts/view.aspx?t=doc&o=GA0070&open=GA0070*.pdf
DVL Compact 500, 6000m, Gen3, Schilling	https://nortek.hsapp.cloud/public/ts/view.aspx?t=doc&o=GA0047&open=GA0047*.pdf
DVL Generation 3 Center Points	https://nortek.hsapp.cloud/public/ts/view.aspx?t=doc&o=GA0018&open=GA0018*.pdf

DVL Generation 2 Mechanical Drawings

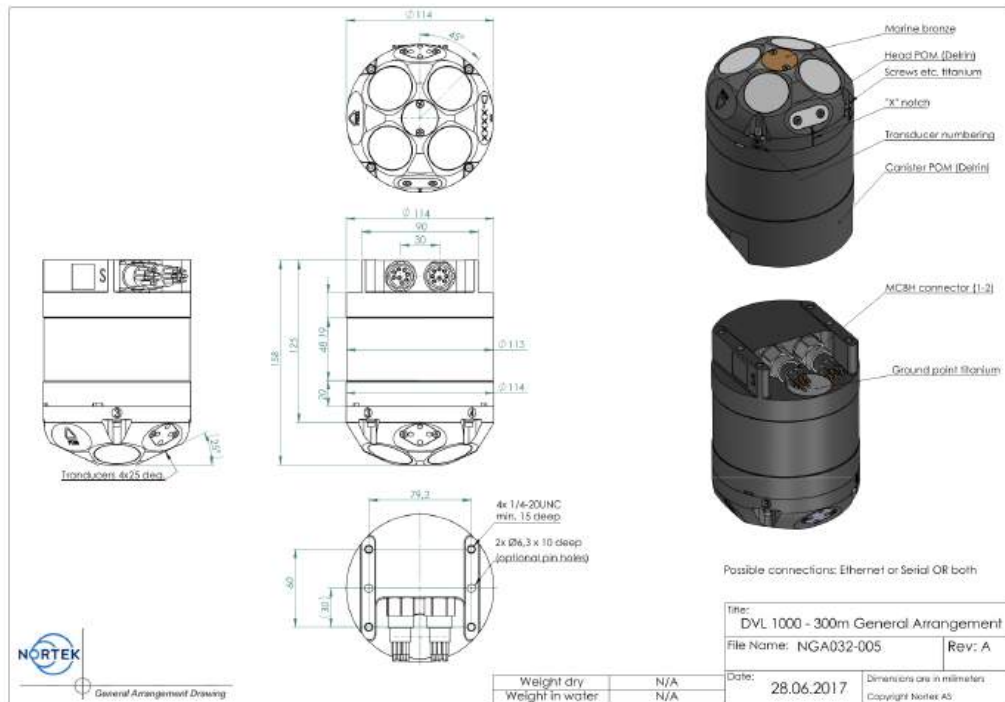

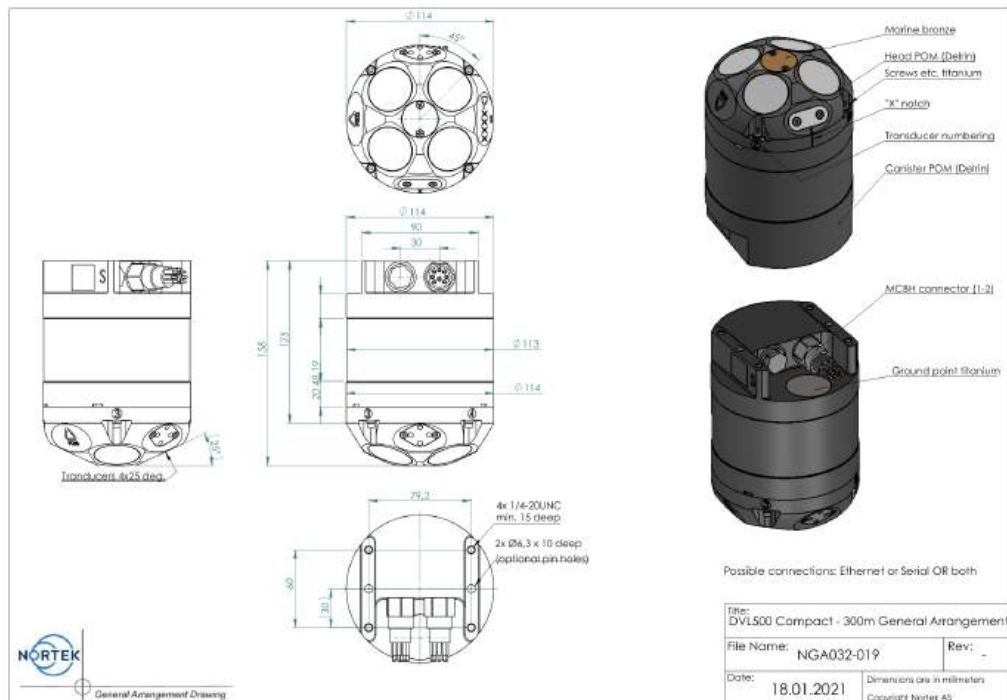
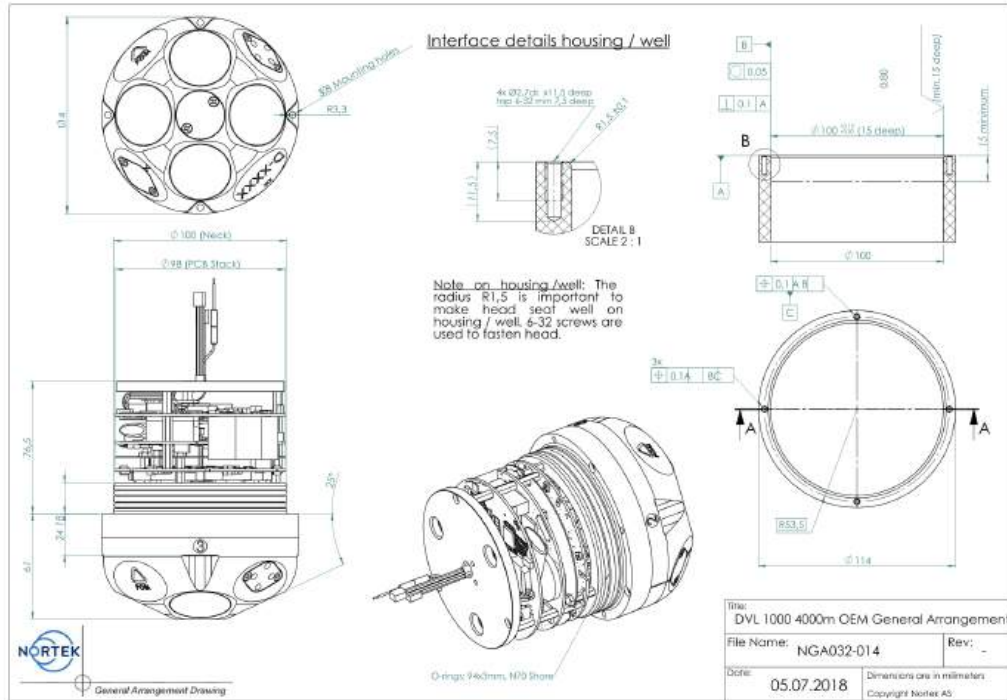

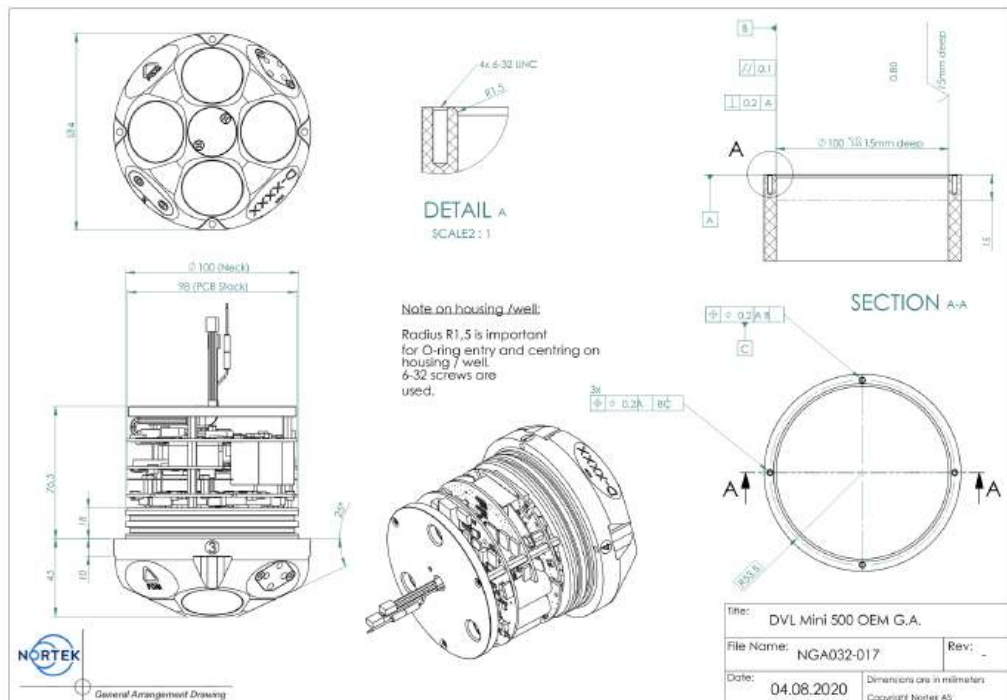
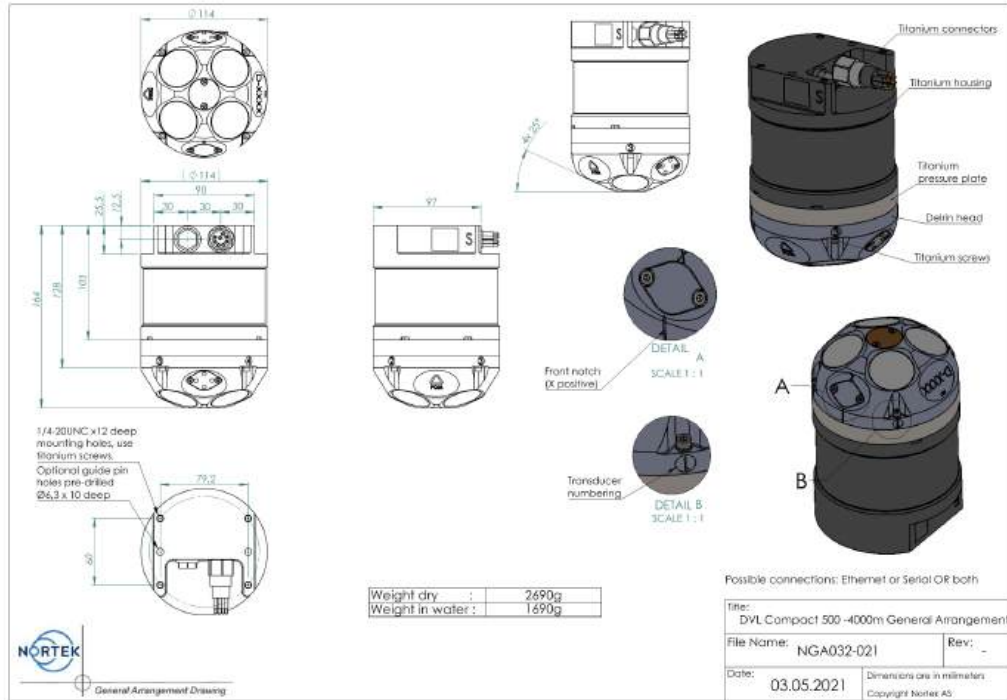

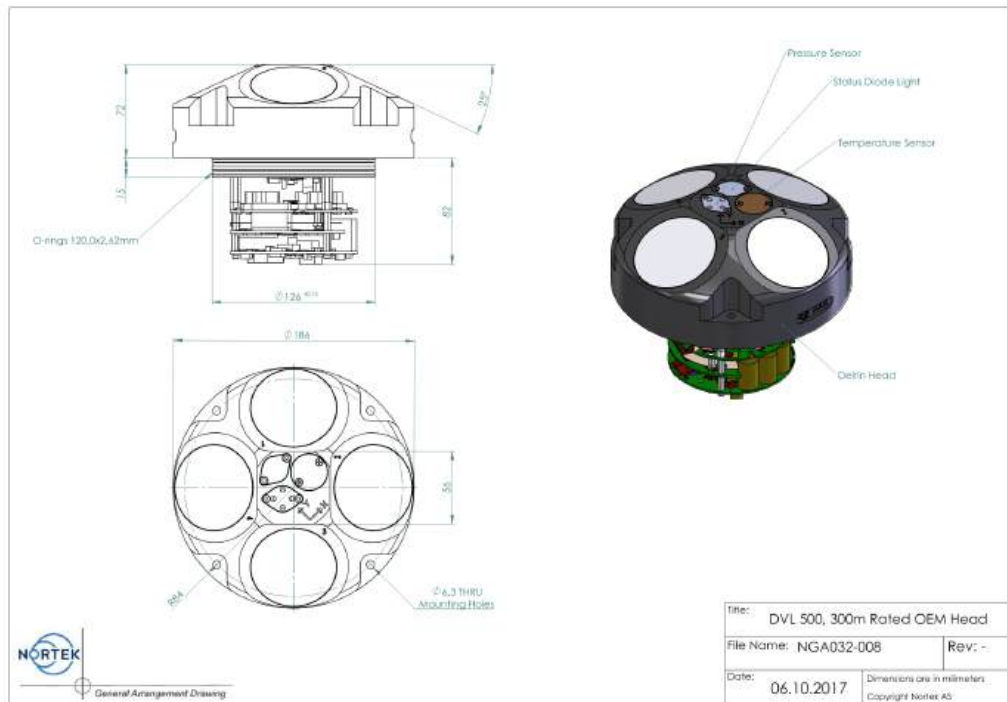
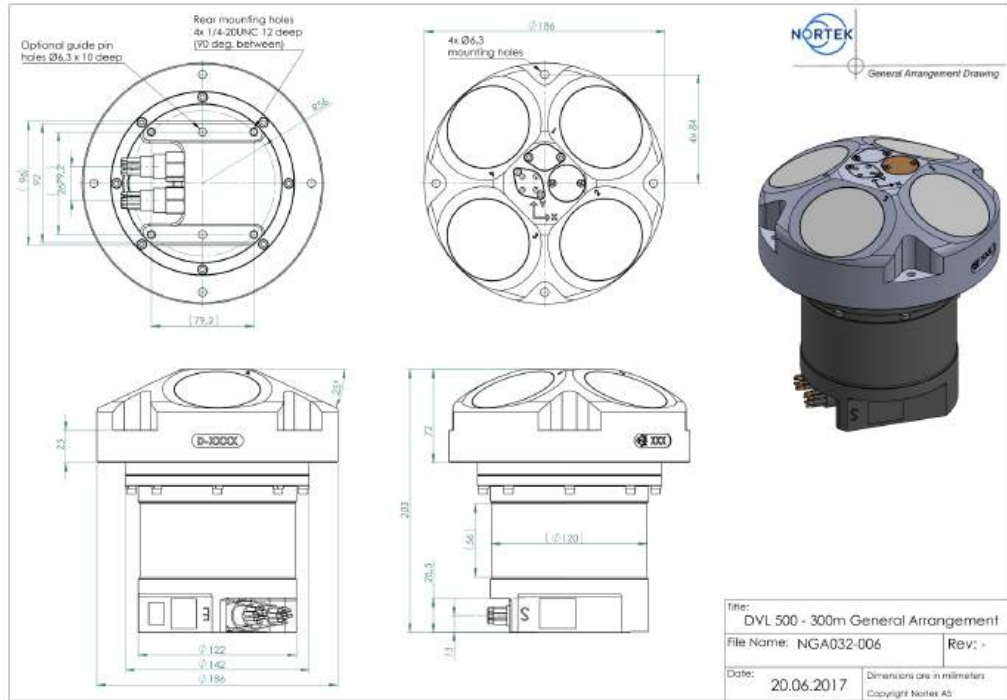

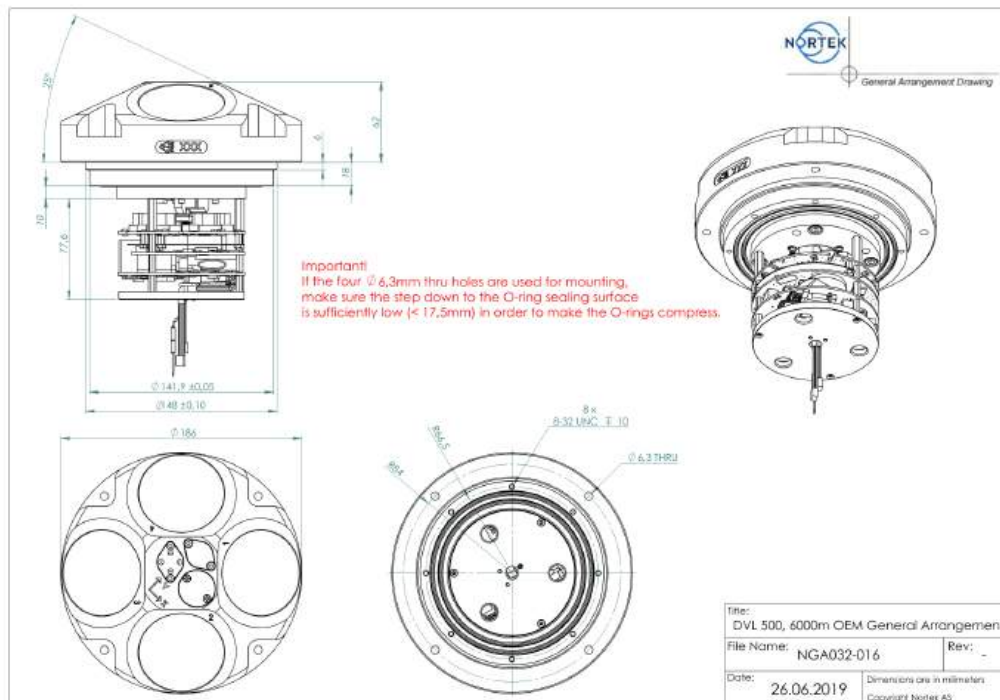
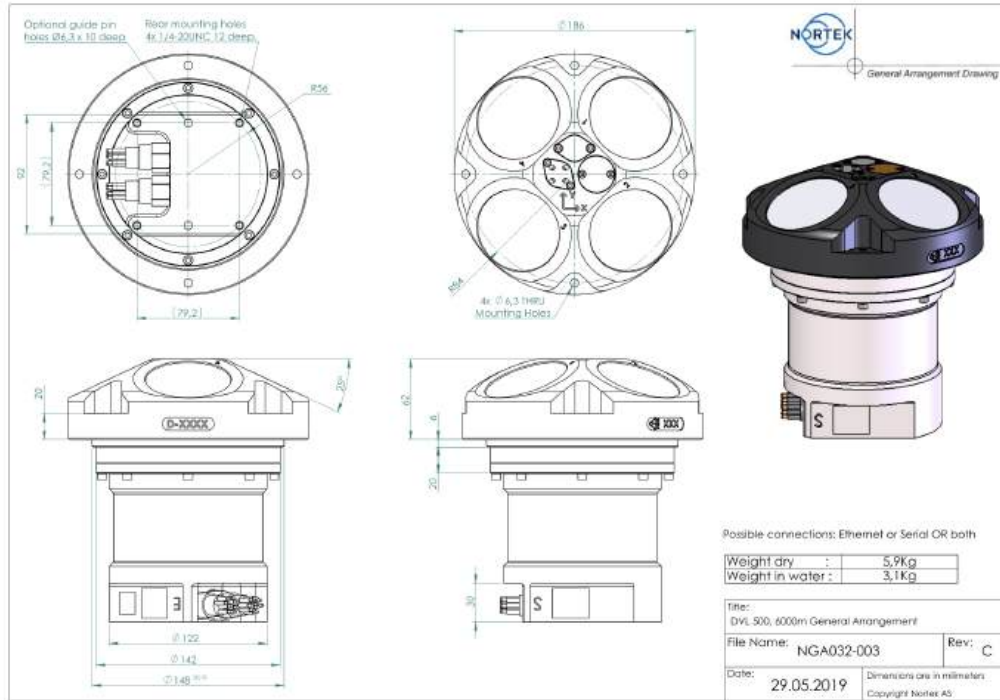

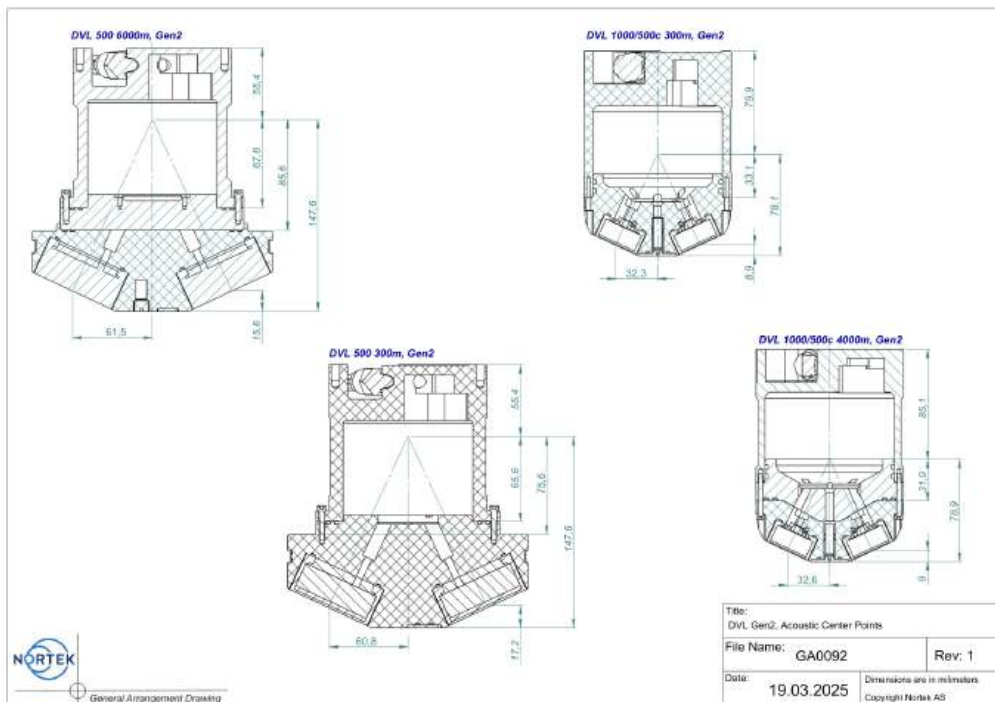

15.7 Proforma Invoice



NOT A SALE

Temporary export to Norway for repair

Sender (Exporter)	Receiver
Name:	Name: NortekAS
Address:	Address: Vangkroken 2
City:	City: N-1351 Rud
Country:	Country: Norway
Tel:	Tel: +47 67 17 45 00
E-mail:	E-mail: support@nortekgroup.com
Ref:	Customs Account No.: 322 68 794
	VAT/Company No.: 996 707 415 MVA

About the goods	
Date:	Description of Goods:
Delivery Terms:	No. of Units:
Delivery method:	Weight:
Tracking no:	Origin: NO
Reason for Export:	Total Value:
Return for repair	Nortek RMA No.:
Temporary	

Place:
Date:
Exporter's Name:

15.8 Sound Pressure Levels

Executive Summary

Doppler Velocity Loggers (DVLs), operating typically at 300–1000 kHz, are widely used in underwater navigation. Due to their high-frequency, narrow, and downward-directed acoustic pulses, they present minimal environmental risk [1], [2]. Current global regulatory frameworks impose **no binding constraints** on DVL sound pressure levels; instead, guidelines and good practice recommendations apply, mainly focusing on low- and mid-frequency sound sources within marine animal hearing ranges [1], [3].

Technical Characteristics

- **Frequencies:** ~333, 500, 1000 kHz
- **Typical source levels:** 180–214 dB re 1 μ Pa @1 m (based on manufacturer specs, regulatory filings, and acoustic modeling) [4], [5], [6]
- **Beam pattern:** Narrow, downward-pointing
- **Pulse type:** Non-impulsive, short duration, low duty cycle

Practical constraints:

- High-frequency sound suffers strong absorption, limiting range [7].
 - Platform energy budgets limit power use [6].
 - Excessive source levels yield diminishing returns due to physics [7].
-

Environmental Impact

- Marine mammals and most marine life **cannot hear above ~180–200 kHz** [1], [8].
 - DVL frequencies are **inaudible to marine fauna** and dissipate within ~10–100 m [1], [7].
 - Regulators classify DVLs as **de minimis sources** due to ultrasonic frequency, low duty cycle, and directional beams [1], [3].
 - There's no evidence of impact on fish or invertebrates [9].
-

Regulatory Overview

United States (NOAA, MMPA)

- Behavioral disturbance threshold: 160 dB re 1 μ Pa RMS (for audible, non-impulsive sounds) [1].
- DVLs (>200 kHz) are outside marine mammal hearing → effectively exempt [1], [3].
- No Incidental Take Authorization typically required [1].

Europe (EU, ICES, UK)

- EU Marine Strategy Framework Directive: focuses on low-frequency continuous noise; DVLs not included [10].
- ICES CRR 209: controls low-frequency vessel noise, not high-frequency sonars [11].
- UK JNCC guidelines: DVL-class devices generally exempt [10].

International (IMO, UNCLOS, ACCOBAMS)

- IMO ship noise guidelines exclude intentional sonars [12].
- UNCLOS general pollution rules; no specific DVL limits [13].

- ACCOBAMS focuses on seismic/mid-frequency sonar, not high-frequency DVLs [14].

Hard Regulations vs. Guidelines

- **No hard regulatory limits (no absolute dB caps) for DVLs globally** [1], [3], [10].
 - Agencies rely on guidelines and best practices [1], [3].
 - DVLs are allowed under current frameworks as long as they operate at ultrasonic frequencies and are documented in environmental reviews when needed [1], [3].
-

Design Recommendations for Next-Gen DVLs

- Maintain operational frequencies ≥ 300 kHz [4], [5].
 - Use only necessary power; typical 180–214 dB re 1 μ Pa is acceptable [4], [5], [6].
 - Apply pulse shaping to minimize lower-frequency spectral leakage [7].
 - Ensure directional, narrow beam patterns [6].
 - Provide clear acoustic specs for environmental documentation [1], [3].
-

Final Notes

The global regulatory consensus is that DVLs pose negligible risk to marine fauna due to their physical characteristics [1], [3]. While formal regulations impose no numeric limits, operators and designers should follow best practices and remain aware of evolving environmental standards [1], [3], [10].

References (IEEE style)

- [1] NOAA, “Technical Guidance for Assessing the Effects of Anthropogenic Sound on Marine Mammal Hearing,” 2018, 2024.
- [2] J. A. Hildebrand, “Anthropogenic and natural sources of ambient noise in the ocean,” *Marine Ecology Progress Series*, vol. 395, pp. 5–20, 2009.
- [3] NOAA Fisheries, Incidental Harassment Authorizations (e.g., ONR Arctic Research IHA).
- [4] Nortek, “Signature Series Technical Specifications,” Manufacturer datasheet.
- [5] Teledyne RDI, “Workhorse Series Datasheet,” Manufacturer datasheet.
- [6] BOEM/USGS, “Acoustic Source Characterization Reports.”
- [7] R. J. Urick, *Principles of Underwater Sound*, 3rd ed. Peninsula Publishing, 1983.
- [8] Southall et al., “Marine Mammal Noise Exposure Criteria: Updated Scientific Recommendations,” *Aquatic Mammals*, vol. 45, no. 2, pp. 125–232, 2019.
- [9] ICES, “Cooperative Research Report No. 209,” 1995.
- [10] European Commission, “Marine Strategy Framework Directive,” 2008.
- [11] ICES, “CRR 209: Underwater Noise of Research Vessels,” 1995.
- [12] IMO, “Guidelines for the Reduction of Underwater Noise from Commercial Shipping to Address Adverse Impacts on Marine Life,” MEPC.1/Circ.833, 2014.
- [13] United Nations, “United Nations Convention on the Law of the Sea (UNCLOS),” 1982.
- [14] ACCOBAMS, “Guidelines on the Reduction of Anthropogenic Noise,” 2018.

15.9 Coordinate System Conversion

Coordinate System Conversion

This section describes how to get from Nortek beam or XYZ coordinates to "legacy instrument coordinates". This section is relevant for customers who replace their existing DVL with Nortek instruments.

The theory behind the redefinition of the coordinate axes is relatively straight forward. The two coordinate systems are as defined in the below figure:

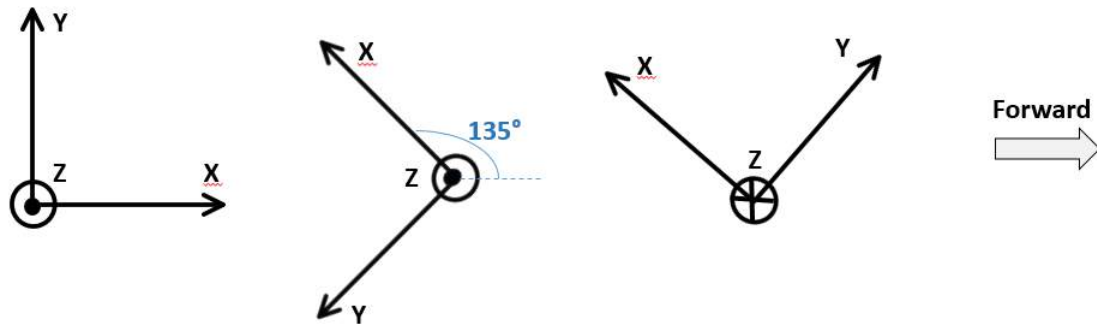

From left: Nortek DVL coordinate system, Legacy coordinate system and definition of "Forward" direction

The rotation that needs to be done is:

$$\begin{bmatrix} X' \\ Y' \\ Z' \end{bmatrix} = \begin{bmatrix} 1 & 0 & 0 \\ 0 & -1 & 0 \\ 0 & 0 & -1 \end{bmatrix} * \begin{bmatrix} \cos(\theta) & -\sin(\theta) & 0 \\ \sin(\theta) & \cos(\theta) & 0 \\ 0 & 0 & 1 \end{bmatrix} * \begin{bmatrix} X \\ Y \\ Z \end{bmatrix}$$

where X' , Y' , Z' is the new coordinate system, the alignment matrix can be set through the web interface, the same goes for the rotational matrix (where theta = 135, counterclockwise), and X , Y , Z is the Nortek data.

Both coordinate systems (legacy and Nortek's) are right-handed orthogonal systems, and they are (by definition) fixed relative to the instrument. The rotation can easily be done through the instruments web site:

- The user can simply use the configuration file "LegacyCoordinateConvention.txt" found under the Documentation tab in the web interface. Download the .txt to your computer and use the Upload Config button (under Measurement Configuration). To confirm the upload was successful, check that the coordinate rotation is updated to 135 degrees. Estimates are transformed to the vehicles forward axis according to the value entered in this field.
- The rotation- and alignment matrix can also be set by using commands. Refer to the [Data Formats](#) section for more information.

15.10 Checksum Definitions

The Checksum is defined as a 16-bits unsigned sum of data (16 bits). The sum shall be initialized to the value of 0xB58C before the checksum is calculated.

C-code for Checksum calculations:

```
unsigned short calculateChecksum(unsigned short *pData, unsigned short size)
{
    unsigned short checksum = 0xB58C;
    unsigned short nbshorts = (size >> 1);
    int i;
    for (i = 0; i < nbshorts; i++)
    {
        checksum += *pData;
        size -= 2;
        pData++;
    }
    if (size > 0)
    {
        checksum += ((unsigned short)(*pData)) << 8;
    }
    return checksum;
}
```

